

The inverter for controlled motion.

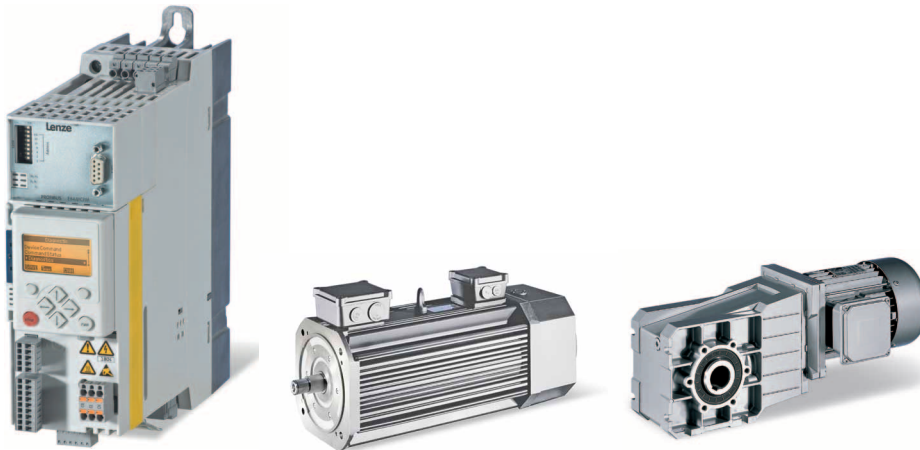

The 8400 StateLine is ideally suited to drive control with or without speed feedback providing precisely tailored solutions. The StateLine is used when communication via bus systems is required. In addition to this, the integrated brake management ensures significant wear reduction on the service brakes.

Highlights

- “VFC eco” energy saving function ensures energy-efficient handling of limited resources
- Control of synchronous motors without feedback
- 200 % overload current

Typical applications for the 8400 StateLine include: palletizers, extruders, filling systems or travelling/variable speed drives.

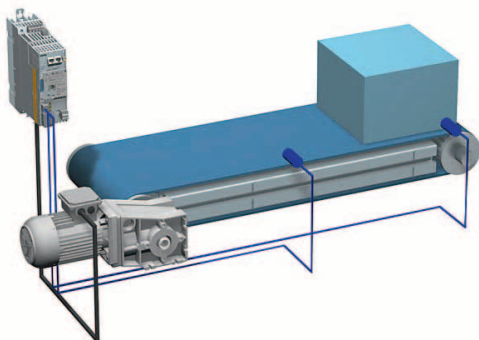

8400 StateLine Technology – At a glance

Performance data	
Mains: 1 AC 230/240 V	0.25 to 2.2 kW
Mains: 3 AC 400/500 V	0.37 to 45.0 kW
Overload current	
	150 % (60 s) 200 % (3 s)
Operating conditions	
	Operating temperature -10 °C to +55 °C (derating above 45 °C: 2.5 %/K) IP20 enclosure
Functions	
	DC brake function Flying restart circuit, PID controller Sensorless vector control "VFC eco" energy saving function Sensorless control of synchronous motors (SLPSM) Brake management for brake control with low rate of wear Logic functions, comparator, counter, arithmetic function
Interfaces	
	Memory modules, L-force diagnostics interface DIP switch for CANopen (on board) Integrated brake chopper External 24 V supply Digital inputs / outputs (5/1), analog inputs / outputs (1/1), relay Slot for EtherCAT, EtherNET/IP, PROFIBUS or PROFINET communication module PTC/thermal contact input
Feedback systems	
	HTL incremental encoder (10 kHz)
Safety engineering	
	Safe torque off (STO), certified to EN 13849-1 (Cat. 4, PL e), IEC 61508/EN 62061 (SIL 3)
Approvals	
	CE, cUL, GOST-R, RoHS

