

Geared motors



G-motion const

G-motion const

Lenze

Lenze

Product code | Geared motors

Type designation

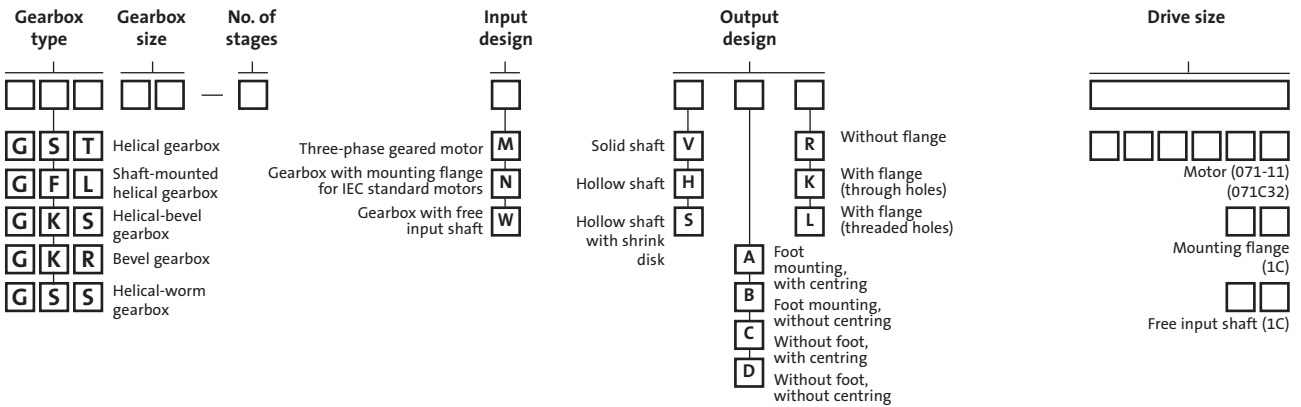

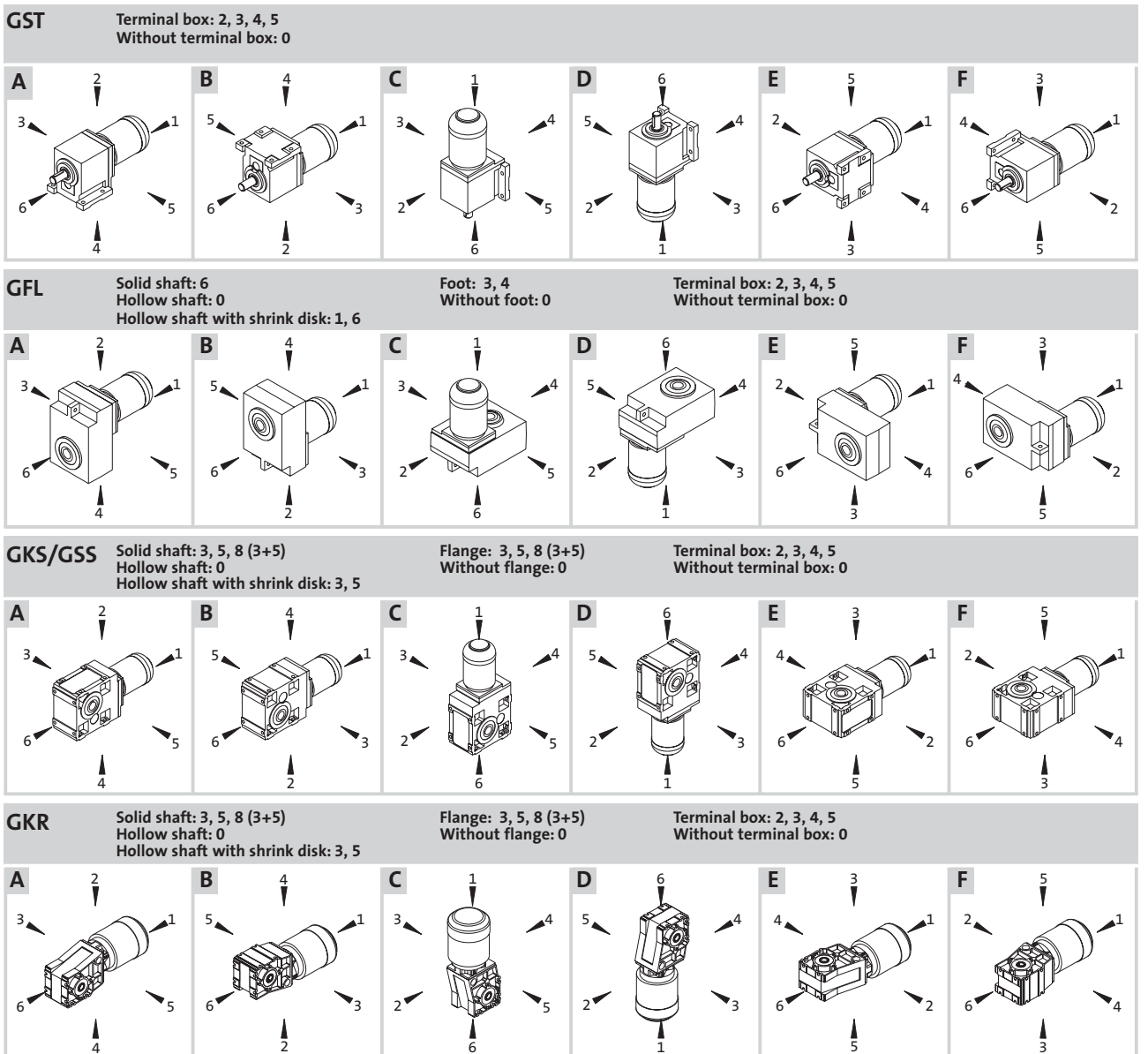

Mounting position (A-F) and position of system elements (1-6)

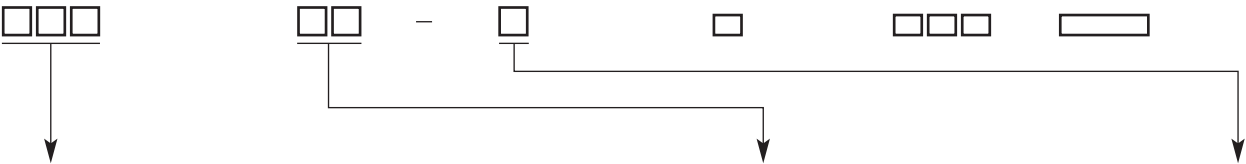

Product code | Geared motors

Type designation

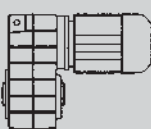
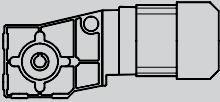
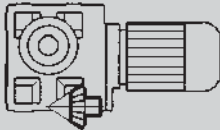
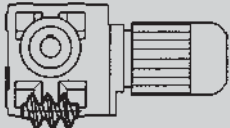

Gearbox type	Gearbox size							No. of stages	
	03	04	05	06	07	09	11	14	
GST 		▲	▲	▲	▲	▲			1
	▲	▲	▲	▲	▲	▲	▲	▲	2
			▲	▲	▲	▲	▲	▲	3
GFL 		▲	▲	▲	▲	▲	▲	▲	2
			▲	▲	▲	▲	▲	▲	3
GKR 	▲	▲	▲	▲					2
GKS 		▲	▲	▲	▲	▲	▲	▲	3
			▲	▲	▲	▲	▲	▲	4
GSS 		▲	▲	▲	▲				2
			▲	▲	▲				3



Geared motors | The system

The rapid pace of development in electronic drive technology is making continuous improvement possible in industrial production processes. It is for this reason that compact distributed drive units are increasingly replacing large central drives – and providing increased speed and improved dynamics. Modern mechatronic systems like those used for example for positioning tasks, require geared motors with low wear, high efficiency and minimum backlash. Lenze can provide a complete range both for mechanical and electronic drive technology applications.

In 1995 Lenze launched the G-motion range, which comprises single-stage and two-stage GST helical gearboxes, two-stage GSS helical-worm gearboxes, two-stage GFL shaft-mounted helical gearboxes (low-profile gearboxes) and three-stage GKS helical-bevel gearboxes. 1999 saw the market launch of Lenze's two-stage GKR bevel gearboxes with aluminium housings. The entire range of geared motors is based on a modular system, which makes it possible to find the ideal operating point for every

customer application. Tried and tested standard products can be used as component parts in custom applications. This G-motion const catalog contains information about geared motors with constant output speed in the power range from 0.06 ... 45 kW. Drives from 0.06 ... 45 kW can be selected in easy-to-use selection tables.

The complete G-motion range also includes solutions for distributed drive systems and servo technology as well as geared motors with mechanical speed control.



New in this catalog:

► Gearboxes

Bevel gearboxes
GKR 06-2M/2N

► Motors

New 4-pole motors in the
power range
2.2 ... 9.2 kW.



Helical geared motors (GST)



Shaft-mounted helical geared motors (GFL)



Helical-bevel geared motors (GKS)

G-motion | The range

Geared motors and gearboxes with constant output speeds

- ▶ Helical geared motors
- ▶ Shaft-mounted helical geared motors
- ▶ Bevel geared motors
- ▶ Helical-bevel geared motors
- ▶ Helical-worm geared motors

G-motion const



Geared motors with built-in 8200 motec frequency inverter

- ▶ Helical geared motors
- ▶ Shaft-mounted helical geared motors
- ▶ Bevel geared motors
- ▶ Helical-bevel geared motors
- ▶ Helical-worm geared motors

G-motion motec



Geared motors with dynamics

- ▶ Helical geared motors
- ▶ Shaft-mounted helical geared motors
- ▶ Bevel geared motors
- ▶ Helical-bevel geared motors
- ▶ Helical-worm geared motors

G-motion servo



Geared motors with mechanical speed control

- ▶ Planetary variable speed drives
- ▶ Belt variable speed drives
- ▶ Variable speed pulleys

G-motion m-var



Bevel geared motors (GKR)



Helical-worm geared motors (GSS)

Contents | G-motion const

General _____	1-1	1
Drive dimensioning _____	2-1	2
Helical gearboxes _____	3-1	3
Shaft-mounted helical gearboxes (low-profile gearboxes) _____	4-1	4
Bevel gearboxes _____	5-1	5
Helical-bevel gearboxes _____	6-1	6
Helical-worm gearboxes _____	7-1	7
Motors _____	8-1	8
Fax order form/Lenze worldwide _____	9-1	9

General | G-motion const

The range	1-2
Product information	1-4
List of abbreviations	1-5
Definitions	1-6
Ordering data	1-7

Geared motors for constant output speeds with high functionality due to numerous gearbox and motor options.

1

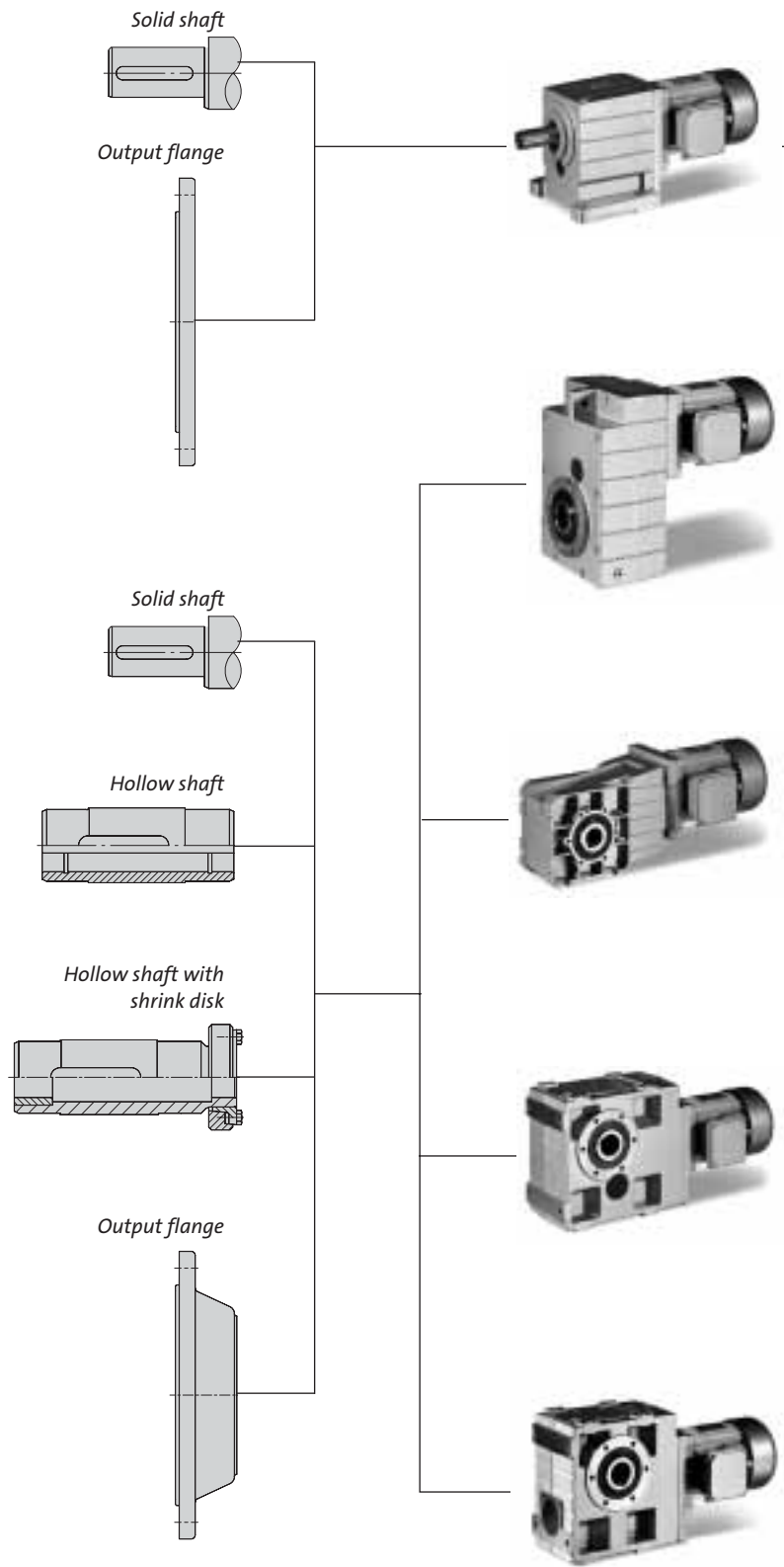

**Helical geared motors
GST**

0.06 to 45 kW
Parallel-axial solid shaft geared motors with foot and flange mounting. As on all other models, the optimised tooth geometry ensures that the gearboxes run particularly smoothly.

**Shaft-mounted helical geared motors
GFL**

0.12 to 45 kW
Recommended for use as compact helical geared motors with hollow shaft mounting. Interference connections without keyways and high quality teeth minimise output backlash on Lenze geared motors.

**Bevel geared motors
GKR**

0.06 to 7.5 kW
Right-angle geared motors in the low torque range with wear-free bevel gears. The comparatively high efficiency means that even in this power range, energy savings can be made.

**Helical-bevel geared motors
GKS**

0.12 to 45 kW
Comparatively high-efficiency solid shaft or hollow shaft right-angle geared motors. Pinpoint output speeds are possible due to the ratio range, which has been carefully stepped.

**Helical-worm geared motors
GSS**

0.12 to 15 kW
Comparatively inexpensive right-angle geared motors with high power density. They can be easily integrated into the machine structure due to an output side pitch circle and mounting surfaces on three sides.

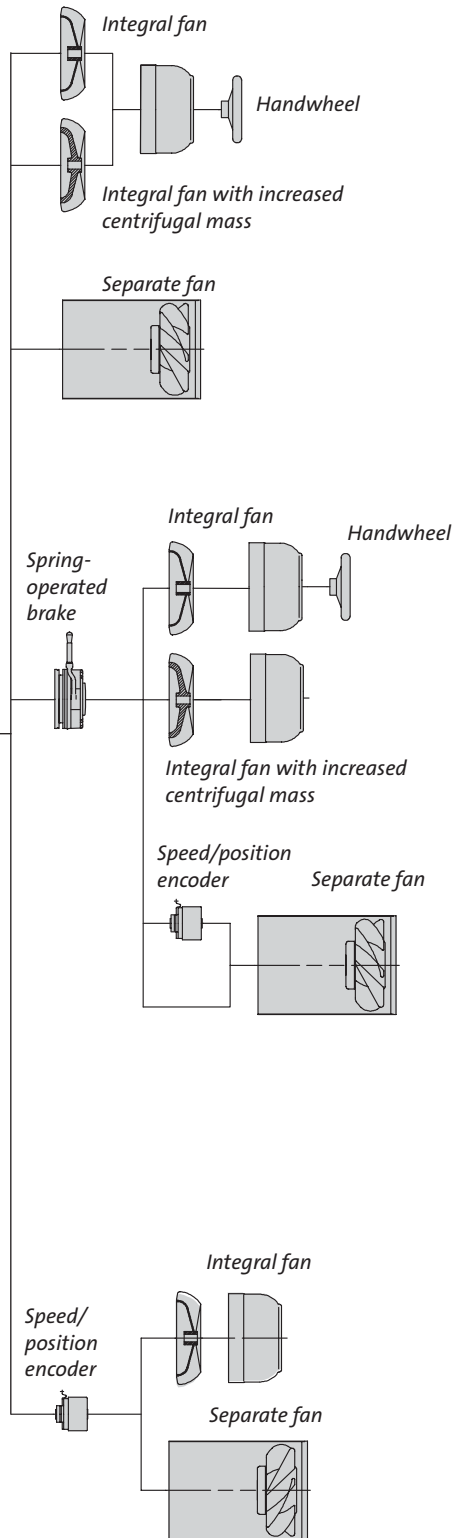

Geared motors

Our quality standards in development, material selection, production and assembly mean that Lenze geared motors in the G□□motion range are able to meet the highest requirements in terms of a durable drive system. The striking design – cubic and compact – fits perfectly with modern industrial design trends.

- ▶ **Geared motors power range**
Lenze geared motors are available in a power range from 0.06 ... 45 kW.
- ▶ **Operational reliability for use in industrial applications**
Even under harsh application conditions, the reliability of the motors is ensured by:
 - Insulation class F
 - IP 55
- ▶ **Options**
Motor options can be supplied for motors from 0.37 ... 9.2 kW and with some limitations for 0.06 ... 0.25 and 11 ... 45 kW.
 - Spring-operated brake
 - Separate fan
 - Variants for thermal monitoring
 - Pluggable connectors
 - Speed/position encoder
 - Increased centrifugal mass
 - Handwheel
 - Second shaft end
 - Condensation drain holes
 - Protection cover
- ▶ **Drive controller compatibility**
The double-coated wire winding with additional phase insulation provides extremely high dielectric strength and has excellent mechanical resistance.

Gearboxes

- ▶ **Compact**
The modular concept and the high power density due to ground gears with optimised gear profiles make extremely compact designs possible.
- ▶ **Adaptable and compatible**
Numerous input and output designs mean that Lenze gearboxes can be adapted to almost any drive task.
- ▶ **Easy to integrate**
The highly functional housings enable Lenze gearboxes to be integrated easily into the machine environment.
- ▶ **Quiet**
The optimum teeth geometry reduces the generation of noise.
- ▶ **Carefully stepped output speeds**
The wide ratio range of the gearboxes combined with the small ratio step $\varphi = 1.12$ enables the required output speed range to be selected with precision.
- ▶ **Reduced play**
The two-stage basic concept (helical-bevel gearboxes are three-stage), connecting elements with reduced play and the high quality of the toothing due to precision manufacturing results in reduced output backlash in comparison with similar geared motors.

Abbreviations used in this catalog

α		Angle of radial force	M_r	[Nm]	Rated torque
c		Load capacity of gearboxes/geared motors	M_A	[Nm]	Motor starting torque
d_w	[mm]	Effective diameter of the transmission element	M_B	[Nm]	Holding torque of brake
$\cos\varphi$		Power factor of the motor	M_{cont}	[Nm]	Continuous torque
$\cos\varphi_N$		Power factor for asynchronous motors	M_{stall}	[Nm]	Stall torque of motor
F_a	[N]	Applied axial force	M_t		Maximum torque factor
F_a	[N]	Permissible axial force	M_{max}	[Nm]	Maximum torque
$F_{a Tab}$	[N]	Table value of axial force	M_{perm}	[Nm]	Permissible torque
f_{ch}	[kHz]	Switching frequency	n_1	[min ⁻¹]	Input speed
f_d	[Hz]	Field frequency	n_2	[min ⁻¹]	Output speed
F_l		Mass acceleration factor	n_r	[min ⁻¹]	Rated speed
f_{max}	[Hz]	Set maximum frequency	n_{max}	[min ⁻¹]	Maximum speed
f_r	[Hz]	Rated frequency	P_1	[kW]	Input power
F_r	[N]	Applied radial force	P_2	[kW]	Output power
$F_{r Tab}$	[N]	Table value of radial force	P_r	[kW]	Rated power
$F_{r perm}$	[N]	Permissible radial force	P_V	[kW]	Inverter power loss
f_w		Additional load factor of applied radial force	R	[Ω]	Resistance
f_α		Effective direction factor of applied radial force	S_r	[kW]	Inverter output power
f_z		Additional radial force factor of the transmission element	T_A	[°C]	Ambient temperature during operation
i		Transmission ratio	U_{DC}	[V]	DC bus voltage
φ		Ratio step	U_r	[V]	Rated voltage
η		Mechanical efficiency	U_{mains}	[V]	Mains voltage
I_0	[A]	Continuous standstill current	IP		International protection code
I_A	[A]	Motor starting current	IEC		International Electrotechnical Commission
I_{max}	[A]	Maximum output current	DIN		Deutsches Institut für Normung
I_r	[A]	Rated current	VDE		Verband deutscher Elektrotechniker
I_{mains}	[A]	Rated mains current	USDA		United States Department of Agriculture
J_{ext}	[kgm ²]	Moment of inertia of the machine to be driven, reduced to the motor shaft	NEMA		National Electrical Manufacturers Association
J_{load}	[kgm ²]	Moment of inertia of the loaded machine	AC		Alternating current/voltage
J_{mot}	[kgm ²]	Moment of inertia of the motor	DC		Direct current/voltage
J_A	[kgm ²]	Moment of inertia of the drive, reduced to the input shaft	EMC		Electromagnetic compatibility
J_B	[kgm ²]	Moment of inertia of the brake	EN		European standard
k		Application factor (according to DIN 3990)	CE		Communauté Européene
L	[mH]	Inductance	IM		International Mounting Code
m	[kg]	Mass			
M_0	[Nm]	Continuous standstill torque			
M_1	[Nm]	Input torque			
M_2	[Nm]	Output torque			

General information about the data provided in this catalog

Ratings, torques and speeds

The ratings, torques and speeds specified in this catalog are rounded values and are valid under the following conditions:

- ▶ Running time/day = 8h (100% DT)
 - ▶ Duty class I at 10 switching operations/h
 - ▶ Mounting positions and models in this catalog
 - ▶ Standard lubricant
 - ▶ $f_{\text{mains}} = 50$ Hz constant
 - ▶ $T_{\text{amb}} = 20^{\circ}\text{C}$ for gearboxes
40°C for motors (in accordance with EN 60034)
 - ▶ Installation height $< = 1000$ m above mean sea level
- The rated power specified for motors and geared motors applies to operating mode S1 in accordance with EN 60034.

If your operating conditions differ, the values that can be obtained may deviate from those specified.

If you are operating under extreme conditions, please contact your nearest Lenze representative.

Load capacity c of gearboxes

Parameter for the load capacity of Lenze gearboxes and geared motors.

- ▶ c is the ratio of the permissible rated torque of the gearbox to the rated torque supplied by the drive component (e.g. the built-in Lenze motor).
- ▶ The value of c must always be greater than the value of the operating factor k calculated for the application.

Operating factor k (corresponding to DIN 3990)

Takes into account the influence of temporally variable loads which are actually present during the anticipated operating time of gearboxes and geared motors.

k is determined by

- ▶ the type of load
- ▶ the load intensity
- ▶ temporal factors

We want to be sure that you receive the correct products in good time. In order to help us to do this, please make sure you provide complete ordering data. Use the checklist below and the order information to help you.

Checklist

In order to receive the correct products in good time, please provide the following information:

- ▶ Your address and ordering data
- ▶ Our product code for the individual products in this catalog
- ▶ Your delivery data, i.e. delivery date and delivery address

How to order

Please use this step-by-step guide and the fax form to ensure that you provide all the necessary information in the correct format. It makes ordering your tailor-made drive extremely easy:

- ▶ Make a copy of the fax order form.
See Section 9.
- ▶ Enter the order data.
- ▶ Post or fax the form to your Lenze sales office.
A list of Lenze sales offices can be found at the end of this catalog.

Delivery

- ▶ All products are packed appropriately and of course checked prior to delivery.

A step-by-step guide to ordering your drive

- Cross-reference
- Result

1

1. Dimension the drive system

- Dimensioning section

2. Specify the type designation

- Product code, selection table
- Gearbox type, gearbox frame size, no. of stages
Example: GST 07-2
- Drive design, motor frame size
Example: M, 090C32

3. Specify the ratio

- Selection table
- Example: $i = 56.250$

4. Specify the output end design

- Product code
- Drive dimensioning section, **Gearbox designs**
- Solid shaft, housing with foot, without flange
Example: V, B, R

5. Specify the mounting position and position of system elements

- Product code
- Example: Mounting position A
Terminal box in position 5

6. Specify the colour

- Drive dimensioning section, **Gearbox designs**
- Example: Paint colour RAL 9018

7. Specify the gearbox options

- Drive dimensioning section, **Gearbox designs**
- Example: Gearbox with ventilation

8. Specify the motor options

- Motors section
- Example: Separate fan 3~
- Product code
- Example: Separate fan terminal box in position 2

A step-by-step guide to ordering your drive

Items i =

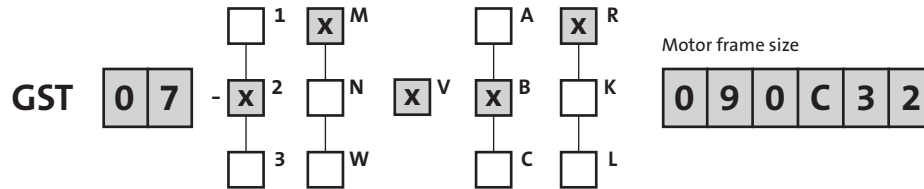

Additional ordering data

Dimensions

K L

Flange a2 = mm

Mounting position

A B C D E F

Position of system elements

Terminal box
2 3 4 5

Colour

Standard
GST 03 No paint (aluminium housing)
GST 04...14 RAL 9018 paint (papyrus white) Grey primer

Options

Ventilation

Ventilation units for frame sizes 05...07 Compensator for frame sizes 09...14 in mounting position C

Motor options

Combination

Separate fan Brake + integral fan Brake + separate fan

Separate fan

1~ 3~
Separate fan terminal box in position 2 3 4 5

Dimensioning

How the duty cycle affects rated data	2-2
How the operating frequency affects rated data	2-2
Power derating	2-3
Torque derating	2-3
Thermal power limit	2-4
Calculating the required load capacity	2-6
Calculating the available axial and radial forces	2-7

Gearbox version

General data	2-8
Basic versions	2-9
Options	2-10
Gearboxes with mounting flange	
Version N	2-11
Gearboxes with free input shaft	
Version W	2-12
Gearboxes with ventilation	2-13
Lubricants	2-14
Roller bearing grease	2-16

Motor versions

General data	2-17
4-pole	
Basic versions	2-18
Options	2-18
Possible combinations for options	2-19
2 and 6-pole	
Basic versions	2-20
Options	2-20
Possible combinations for options	2-21
Configuration aid	2-22

How the duty cycle affects rated data

The operating mode is important when selecting a motor. For example, the temperature rise on a motor subject to short-term load will be lower than that on a motor subject to long-term load and can therefore be set to a lower value. Duty cycles S1 to S8 to EN 60034 apply.

Operation at increased power is possible in duty cycles other than S1. The table below contains guide values for increased power P_{perm} for operating modes S2, S3 and S6.

Continuous operation S1

The operating time at rated power is long enough for the machine to reach steady-state temperature. The motor operates continuously at rated power.

Short-term operation S2

In comparison with the subsequent pause, the operating time is too short for the machine to reach steady-state temperature. During the subsequent lengthy pause, the motor cools down to the initial temperature.

Intermittent operation S3, S4, S5

Cycles of the same type combine to form a sequence. The cycle time is usually 10 minutes.

- ▶ S3: The start-up current is not significant for the temperature rise of the motor.
- ▶ S4: The start-up current contributes to the temperature rise of the motor.
- ▶ S5: The start-up current and braking current contribute to the temperature rise of the motor.

Continuous operation with intermittent loading S6

The motor continues to be ventilated during the no-load phases, enabling it to cool down.

Uninterrupted operation with acceleration and braking S7

The motor runs almost without pauses.

Uninterrupted operation S8 with pole-changing

The machine runs constantly under load but with frequent speed variation.

Increased power in duty cycles S2, S3 and S6

Duty cycle S2		Duty cycle S3		Duty cycle S6	
Operating time [min]	$\frac{P_{perm}}{P_r}$	Operating time [%]	$\frac{P_{perm}}{P_r}$	Operating time [%]	$\frac{P_{perm}}{P_r}$
10	1.4 ... 1.5	15	1.4 ... 1.5	15	1.5 ... 1.6
30	1.15 ... 1.2	25	1.3 ... 1.4	25	1.4 ... 1.5
60	1.07 ... 1.1	40	1.15 ... 1.2	40	1.3 ... 1.4
90	1.0 ... 1.05	60	1.05 ... 1.1	60	1.15 ... 1.2

How the operating frequency affects rated data

Frequency	Voltage	Power	Speed	Torque	Starting torque
f in Hz	$\frac{U}{U_r}$ in %	$\frac{P}{P_r}$ in %	$\frac{n}{n_r}$ in %	$\frac{M}{M_r}$ in %	$\frac{M_A}{M_{Ar}}$ in %
50	100	100	100	100	100
60	100	100	120	83	70
60	120	120	120	100	100



Power derating

Effect of the installation height

How the installation height above mean sea level affects rated power				
H [m]	≤ 1000	2000	3000	4000
$\frac{P_h}{P_r}$	1	0.95	0.90	0.85

Effect of the ambient operating temperature

How the ambient operating temperature T_{amb} affects rated power					
T_{amb} [°C]	≤ 40	45	50	55	60
$\frac{P_{\vartheta}}{P_r}$	1	0.95	0.90	0.85	0.80

Calculating the derated power

$$P_{red} = \frac{P_h}{P_r} \cdot \frac{P_{\vartheta}}{P_r} \cdot P_r$$

Torque derating

Torque derating dependent upon motor frame size with self-ventilation and operation on frequency inverter

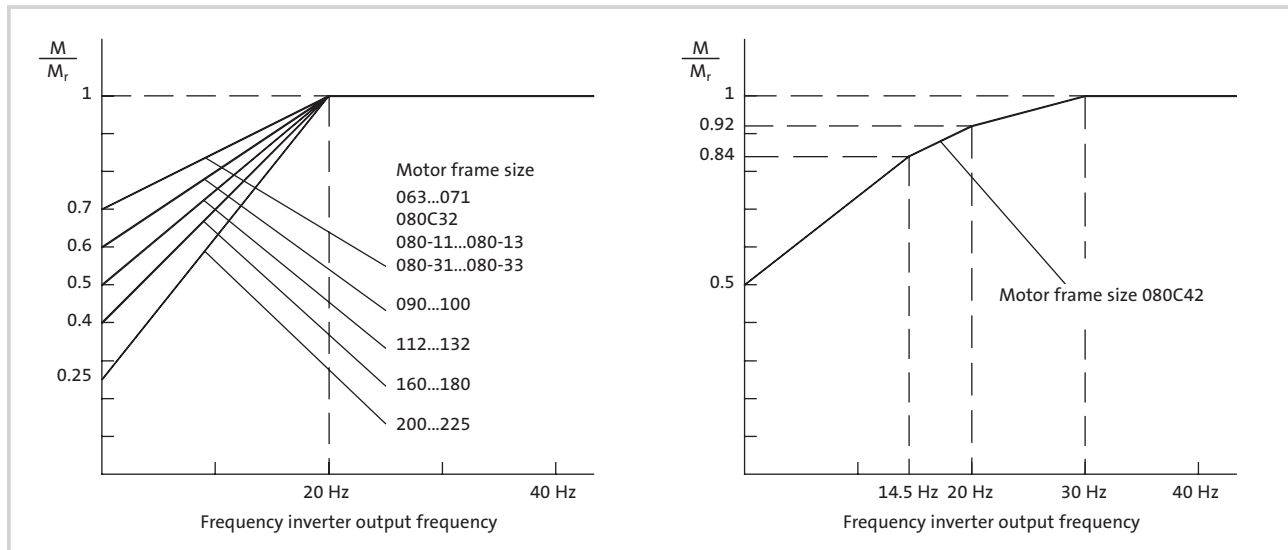

Thermal power limit

The permissible gearbox continuous power is restricted by:

- ▶ The mechanical rating, defined by the material strength of the individual components or
- ▶ The thermal power limit, defined by the heat balance.

The thermal power limit may be lower than the mechanical rating indicated in the selection tables.

The thermal power limit is determined by:

- ▶ Losses in the lubricant. These are determined by the mounting position and the circumferential speed of the gears.
- ▶ The load and the speed
- ▶ The ambient conditions: Temperature, air circulation, heat input or dissipation via shafts and the substructure.

2

Please contact Lenze

- ▶ If you are using the following gearbox model, size and ratio combinations at input speed $n_1 > 1500$ rpm:

Gearbox model	Gearbox sizes	Ratios $i \leq$
Helical gearbox GST	07, 09, 11, 14	10
Shaft-mounted helical gearbox GFL	09, 11, 14	16
Helical-bevel gearbox GKS	09, 11, 14	25

... or if the input speeds n_1 listed are exceeded:

		Drive size		
Input design	M	063 ... 100	112 ... 132	160 ... 225
	N, W	□A ... □E	□F ... □G	□H ... □K
n_1 for mounting positions A, B, E, F		4000 rpm	3000 rpm	2000 rpm
n_1 for mounting positions C, D		3000 rpm	1500 rpm	1500 rpm

Possible ways of extending the field of operation

What to do	
Increase the permissible temperature range of the gearbox	<ul style="list-style-type: none"> ▶ Synthetic lubricant (option) ▶ Shaft sealing rings made from FP material/Viton (option)
Reduce the power loss	<ul style="list-style-type: none"> ▶ Synthetic lubricant (option) ▶ Reduce the amount of lubricant used
Increase the heat dissipation	<ul style="list-style-type: none"> ▶ Possible air convection on the machine/system ▶ Fan cooling (for example pneumatic supply line of the driving motor) ▶ Oil cooling



1. Calculate the required load capacity

Work out the output torque M_2 and speed n_2 required

$$P_1 = \frac{M_2 \cdot n_2}{9550 \cdot \eta}$$

Calculate the duty class:

Duty class	Type of load	Intensity	
I	Smooth running, minor or negligible shocks	$F_I \leq 1.25$	F_I (geared motor) = $\frac{J_{ext} + J_{mot}}{J_{mot}}$
II	Irregular running, average shocks	$1.25 < F_I \leq 4$	
III	Irregular running, major shocks and/or alternating loads	$F_I > 4$	F_I (gearbox) = $\frac{J_{ext} + J_A}{J_A}$

Calculate the temporal factors:

- ▶ Running time/day
- ▶ Switching operations/hour

Use the diagram to determine the operating factor k of the machine

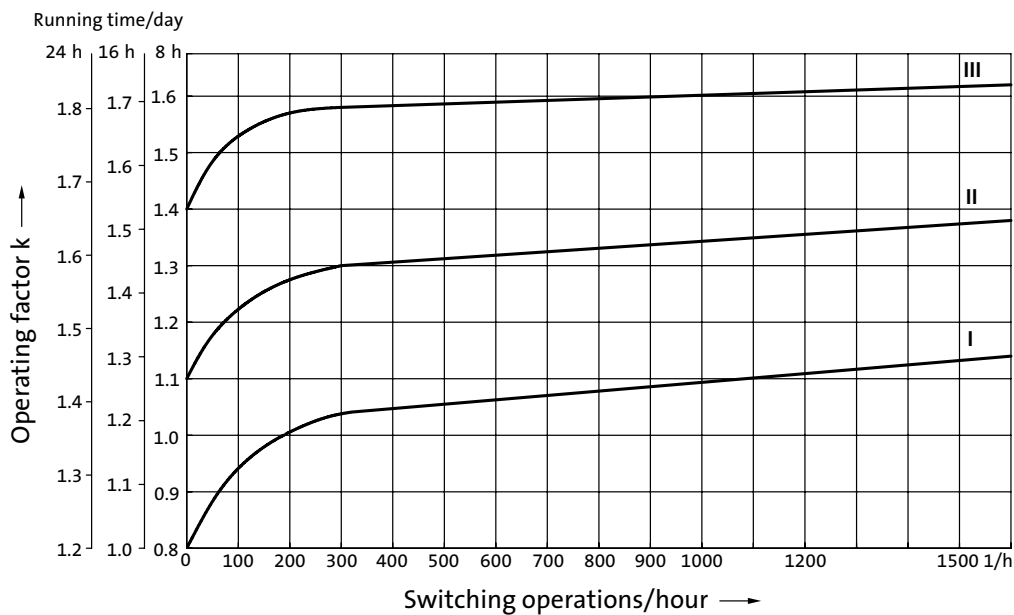

Requirement for geared motor: c (selection table) $\geq k$
 Requirement for gearbox: $M_{2 \text{ perm}}$ (selection table) $\geq M_2 \cdot k$



2. Calculate the axial and radial forces applied to the gearbox shaft

Work out the axial and radial forces applied
Approximate calculation of radial forces:

↓

$$F_r = 2000 \cdot \frac{M_2 \cdot f_z}{d_w [\text{mm}]}$$

f_z	Transmission element
1.12	Gears
1.25 ... 1.4	Chain wheels
1.5	Toothed-belt pulleys
1.5 ... 2.0	Small V-belt pulleys depending on pretension

↓

Requirement:

- ▶ $F_{rperm} \geq F_r$
(F_{rperm} taken from gearbox-specific data)
- ▶ $F_{aperm} \geq F_a$
(F_{aperm} taken from gearbox-specific data)

General data

		GST	GFL	GKR	GKS	GSS
Housing	Version	Cuboid				
	Material	Aluminium/Cast iron				
Solid shaft	Version	With featherkey to DIN 6885				
	Tolerance	k6 (d ≤ 50 mm) m6 (d > 50 mm)				
	Material	Tempered steel C45/42CrMo4				
Hollow shaft	Version	–	H: With keyway S: Smooth			
	Tolerance	–	Bore H7			
	Material	–	Tempered steel C45			
Toothed parts	Version	Optimised tooth flanks and profile geometry Ground tooth flanks				
	Material	Case hardened steel				
Shaft-hub connection		1st stage/prestage/helical (bevel) gearbox: Friction-type connection Output stage (= 2nd, 3rd or 4th stage): Friction-type or positive-fit connection				
Shaft sealing rings	Version	With dust protection lip				
	Material	NB/FP				
Bearings	Version	Ball bearing/tapered-roller bearing depending on size and version				
Lubricants	Version	In accordance with DIN 51502				
	Fill volumes	Depends on the mounting position ⇒ Operating Instructions				
Mechanical efficiency	At rated torque	0.95 ≤ η ≤ 0.97	0.95 ≤ η ≤ 0.97	0.95 ≤ η ≤ 0.96	0.92 ≤ η ≤ 0.95	0.75 ≤ η ≤ 0.90 ▶ Not dep. on transmiss. ratio ▶ At n ₁ = 1400 rpm ▶ Housing at operating temperature and teeth run in
		Does not exceed the emission values specified in VDI Guideline 2159				

Options

Gearbox type	Gearbox size	No. of stages	Input design	Shaft			Options						Lubricants		Colour			
				2nd solid shaft end	Reinforced shaft bearing	Shaft sealing ring FP (Viton)	Rubber buffer set	Torque plate on pitch circle	Torque plate on housing foot	Hollow shaft jet-proof cover	Shrink disc cover	Ventilation units	Reservoir (ventilation) for mounting position C	Synthetic CLP HC 320	Food-compatible CLP HC 220	Special paint to RAL number	Grey primer	
Product code				V														
GST	03	2	M														▲	
	04	1	M N W		▲													
		2																
	05	1																
		2/3																
	06	1				▲								▲	▲	▲		
		2/3																
	07	1																
		2/3																
	09	1																
		2/3																
	11	2/3					1)											
	14	2/3					1)											
	GFL	04		2	M N W													
05		2/3																
06		2/3																
07		2/3		2)		▲	▲				▲			▲	▲	▲		
09		2/3																
14		2/3																
GKR	03	2	M N				▲	▲									▲	
	04	2		▲		▲	▲										▲	
	05	2					▲	▲		▲								▲
	06	2					▲	▲		▲								4)
GKS	04	3	M N W															
	05	3/4																
	06	3/4																
	07	3/4			2)	▲				▲	▲			▲	▲	▲		
	09	3/4																
	14	3/4																
GSS	04	2	M N W															
	05	2/3		▲	2)	▲												
	06	2/3													3)	▲		
	07	2/3																

1) Standard bearing

2) On request

3) Torque derating required: $M_2 \text{ perm.} = M_2 \cdot 0.8$

4) For version "drive N" basic design



Gearboxes with mounting flange Version N

Mounting flange:

- ▶ Flange dimensions suitable for motors to IEC 72/DIN 42948
- ▶ Shaft in two bearings
- ▶ Gearbox half-coupling integrated into the shaft

Spider (coupling element):

- ▶ Torsionally stiff
- ▶ Angle-synchronous
- ▶ Reduced backlash (no backlash with clamping hub/ clamping ring hub)

Coupling hub:

- ▶ Standard: Coupling hub with keyway for motor shafts to IEC
- ▶ Optional coupling hubs for frequent shocks and alternating load or reduced coupling backlash:
 - Clamping hub with tangential clamping screw for motor shafts with keyway, no backlash
 - Clamping hub with tangential clamping screw for motor shafts with featherkey, no backlash

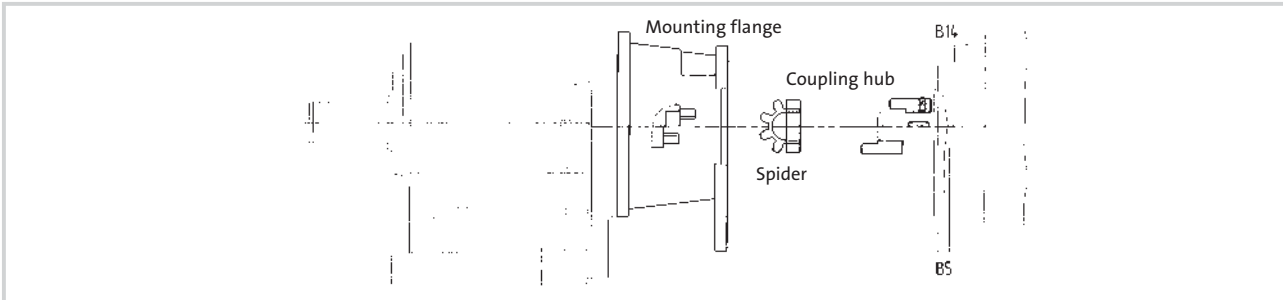

Geometric assignments for motors

See the selection tables for gearboxes with mounting flanges for the permissible input ratings and output torques.

Lenze Drive size	IEC motors		Lenze				Coupling hub		Dimensions			Motor shaft		
	Size	Design	Size	Design	Size	Design	Standard clamping hub	Clamping ring hub	Flange size a3	Pitch circle e3	Centring b3	d	I _{min}	I _{max}
1A	63	B14	MD□□ 036	B5			▲	▲	C90	75	60	11	23	23
1B	71	B14	MD□□ 056	B14			▲	▲	C105	85	70	14	30	30
2B	63	B14	MD□□ 036	B5			▲	▲	C90	75	60	11	23	23
1C	80	B14	MD□□ 071	B14/B5	MGF□□ 63	B34	▲	▲	C160	130	110	19	25	40
2C							▲	▲	C160	130	110	14	25	40
3C	71	B14	MD□□ 056	B14			▲	▲	C105	85	70	14	25	40
4C	71	B14	MD□□ 056	B5			▲	▲	C120	100	80	14	25	40
1D	90	B14	MD□KA 080 MD□KA 090	B14	MGFRK 90 MGF□□ 80	B14 B34	▲		C160	130	110	24	50	50
2D	80	B14	MD□□ 071	B14/B5	MGF□□ 63	B34	▲	▲	C160	130	110	19	40	50
1E	100 112	B14	MD□KA 100	B14	MGFRK 100 MGFRK 112 MGF□□ 100	B14 B14 B34	▲	▲	C160	130	110	28	30	60
2E	90	B14	MD□KA 080 MD□KA 090	B14	MGFRK 90 MGF□□ 80	B14 B34	▲	▲	C160	130	110	24	30	60
3E	80	B14	MD□□ 071	B14/B5	MGF□□ 63	B34	▲	▲	C160	130	110	19	30	60
1F	100 112	B14	MD□KA 100	B14	MGFRK 100 MGFRK 112 MGF□□ 100	B14 B14 B34	▲	▲	C160	130	110	28	30	60
2F	90	B14	MD□KA 080 MD□KA 090	B14	MGFRK 90 MGF□□ 80	B14 B34	▲	▲	C160	130	110	24	30	60
1G	132	B5	MD□KA 112 MDFQA 100 MDFQA 112	B5 B5 B35	MGFRK 132 MGF□□ 112 MGF□□ 132	B5 B35 B35	▲	▲	A300	265	230	38	80	80
2G	100/112	B5	MD□KA 100	B5	MGF□□ 100	B35	▲	▲	A250	215	180	28	60	60
3G			MD□KA 112 MDFQA 110	B5 B5			▲	▲	A250	215	180	38	80	80
1H	160	B5			MGFRK 160	B5	▲		A350	300	250	42	110	110
2H	180	B5			MGFRK 180	B5	▲		A350	300	250	48	110	110
3H	132	B5	MD□KA 112 MDFQA 100 MDFQA 112	B5 B5 B35	MGFRK 132 MGF□□ 112 MGF□□ 132	B5 B35 B35	▲	▲	A300	265	230	38	80	80
1K	200	B5	MDFQA 132	B5	MGFRK 200 MGF□□ 160	B5	▲		A400	350	300	55	110	110
2K	225	B5			MGFRK 225	B5	▲		A450	400	350	60	140	140

Dimensions in [mm]

Gearboxes with free input shaft Version W

Possible combinations

Various drive sizes are available for selection for every gearbox size (except for GST 03, GKR). They differ in terms of:

- ▶ Transferrable torque
- ▶ Permissible radial and axial forces
- ▶ Shaft geometry
- ▶ The modified overall dimensions of the gearbox (see dimension drawings)

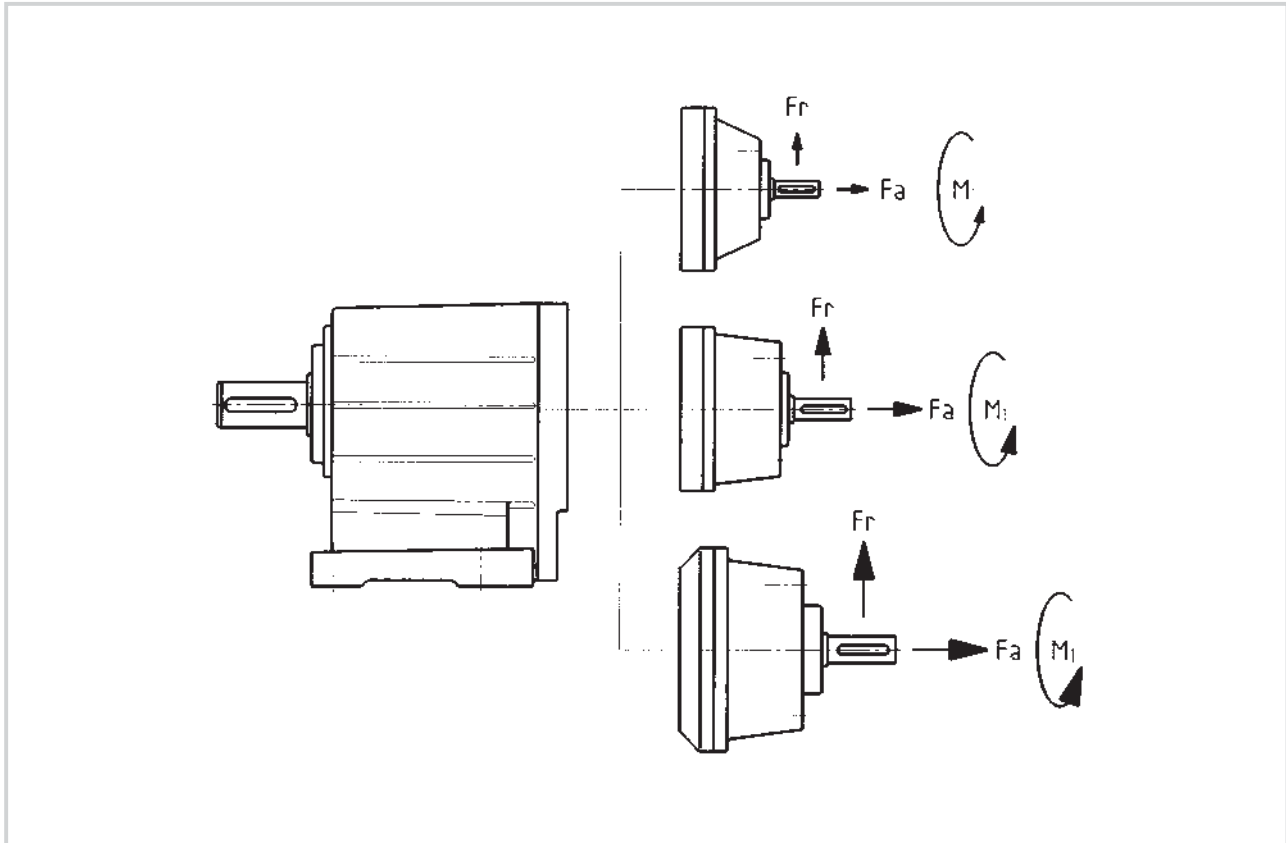

Lenze Drive size	Input shaft	
	d	l
1A	14	35
1B	14	35
1C	14	40
1D	19	50
1E	24	60
1F	28	80
1G	38	100
1H	42	110
1K	48	110

Dimensions in [mm]



Gearboxes with ventilation

Gearbox sizes 03 to 07

Ventilation does not need to be provided on size 03/04 and GKR 05/06 gearboxes.

If you are using gearbox sizes 05 to 07 you will not need to provide special means of ventilation in most cases. In borderline cases, e.g. at input speeds > 2000 rpm we recommend the use of ventilation units, which we can supply separately.

Gearbox sizes 09 to 14

Ventilation units are always supplied with these gearbox sizes.

Special precautions for mounting position C (motor on top)

We recommend the use of an oil compensation reservoir for gearbox sizes 09 to 14 in this mounting position.

See the Technical data, Ventilation section for diagram and dimensions. This product can be ordered separately. It is not required at high ratios or low input speeds.

Please contact Lenze if this affects your application.

Lubricants

Lenze gearboxes and geared motors are supplied ready for operation containing drive-specific and type-specific lubricant. The lubricant delivered with the product will have been taken from the column for the relevant Lenze unit. When ordering your product, please specify the mounting position and design as this will determine the amount of lubricant.

We would like to draw your attention to the fact that if Lenze recommends an oil/grease or includes it in a Lenze

lubricants table, this does not make Lenze liable in any way for any damage due to incompatibilities with the materials used.

The lubricants listed in the lubricants table on the following page may be used for Lenze drives. Special lubricants have to be used e. g. in the event of long-term storage or extraordinary operating conditions.

2

Please note the following key for the lubricant table when selecting lubricants:

CLP = Mineral oil

CLP PG = Polyglycol oil

CLP HC = Synthetic hydrocarbons/poly-alpha-olefin oil

CLP E = Diester oil (water pollution class WGK 1)

1) = Currently, we do not have any performance test data for the lubricants listed for lubricating worm gearboxes. When using these oils, the permissible torque values in the catalog should be reduced by 20%.

2) = Polyglycol oil cannot be mixed with other types of oil.

3) = At ambient temperatures above 40°C, please contact Lenze to discuss the exact application conditions.

4) = Note critical starting performance at low temperatures. At temperatures below -25°C, special measures are required for the motor bearing and NBR shaft sealing rings.



= Food-compatible oil (approved to USDA-H1)



= Bio oil (lubricant for forestry, farming and water management)
(water pollution class 1)



= Low-temperature oils, note critical starting performance at low temperatures



= Lenze lubricants used during factory assembly



Lubricant table

	Ambient temperature			DIN 51517-3: CLP ISO 12925-1: CKC/CKD		GST, GFL, GKS, GKR		GSS
	-50	0°C	+50					
	0		+40		CLP	VG 460	Omala 460	
	-25		+50	3)	CLP HC	VG 320	Omala HD 320	
	-10		+50	3)	CLP HC	VG 460	Cassida Fluid GL 460	
	-20		+40		CLP HC	VG 220	Cassida Fluid GL 220	
	-20		+40		CLP PG	VG 220		Tivela S 220 2)
	-20		+40		CLP PG	VG 460		Tivela S 460 2)
	-40	0		4)	CLP HC	VG 46	Cassida HF 46	
	-20		+40		CLP PG	VG 320		Cassida Fluid WG 320 1) 2)
	-20		+50	3)	CLP E	VG 320	Omala EPB 320	Omala EPB 320 1)
		0		+40		CLP	VG 460	Klüberoil GEM1 460
-25			+50	3)	CLP HC	VG 320	Klübersynth EG 4-320	
-20			+40		CLP PG	VG 460		Klübersynth GH 6-460 2)
-20			+40		CLP PG	VG 220		Klübersynth GH 6-220 2)
-30		0		4)	CLP PG	VG 32		Klübersynth GH 6-32 1) 2)
-40		0		4)	CLP HC	VG 46	Klüber Summit HySyn FG-46	
-20			+40		CLP HC	VG 220	Klüberoil 4 UH1-220 N	
-20			+40		CLP PG	VG 320		Klübersynth UH1 6-320 1) 2)
-20			+50	3)	CLP E	VG 320	Klübersynth GEM 2-320	Klübersynth GEM 2-320 1)
		-25		+50	3)	CLP HC	VG 320	Renolin Unisyn CLP 320
	-20		+40		CLP E	VG 320	Plantogear 320 S	Plantogear 320 S 1)
	-20		+40		CLP PG	VG 460		Renolin PG 460 1) 2)
	0		+40		CLP	VG 460	Renolin CLP 460	
	-10		+50	3)	CLP HC	VG 460	Eural Gear 460	
	-25		+40		CLP HC	VG 220	Eural Gear 220	
	-20		+40		CLP PG	VG 460		Degol GS 460 1) 2)
	0		+40		CLP	VG 460	Degol BG 460	
	-25		+50	3)	CLP HC	VG 320	Degol PAS 320	
	0		+40		CLP	VG 460	Blasia 460	
	-25		+50	3)	CLP HC	VG 320	Blasia SX 320	
	0		+40		CLP	VG 460	Energol GR-XP 460	
	-20		+50	3)	CLP HC	VG 320	Energol HTX 320	
	0		+40		CLP	VG 460	Alpha MW 460	
	0		+40		CLP	VG 460	Alpha SP 460	
	-20		+40		CLP PG	VG 460	Alpha PG 460 2)	Alpha PG 460 1) 2)
	0		+40		CLP	VG 460	Falcon CLP 460	
	-20		+40		CLP PG	VG 460		Polydea PGLP 460 1) 2)
	-20		+50	3)	CLP E	VG 320	Ergon ELP 320	Ergon ELP 320 1) 2)
	0		+40		CLP	VG 460	Spartan EP 460	
	-20		+40		CLP PG	VG 460		Glycolube 460 1) 2)
	-25		+50	3)	CLP HC	VG 320	Spartan Synthetic EP 320	
	0		+40		CLP	VG 460	Mobilgear 634	
	-20		+40		CLP PG	VG 460		Mobil Glygoyle HE 460 1) 2)
	-20		+50	3)	CLP HC	VG 320	Mobilgear SHC XMP 320	
	0		+40		CLP	VG 460	Turmogearoil 460 OM	
	-25		+50	3)	CLP HC	VG 320	Turmofluid GV 320	
	-20		+40		CLP PG	VG 460		Turmopoloil 460 EP 1)
	-20		+40		CLP PG	VG 220		Turmopoloil 220 EP 1)
	-40	0		4)	CLP HC	VG 46	Turmofluid GV 46	
	-20		+40		CLP HC	VG 220	Turmosynthoil GV 220	
	-20		+40		CLP PG	VG 460		Turmosynthoil PG 460 1) 2)
	-20		+50	3)	CLP E	VG 320	Turmofluid Biolube CLP 320	Turmofluid Biolube CLP 320 1)
	0		+40		CLP	VG 460	Optigear BM 460	
	-25		+50	3)	CLP HC	VG 320	Optigear Synthetic A 320	
	0		+40		CLP	VG 460	Tribol 1100/460	
	-20		+40		CLP PG	VG 460		Tribol 800/460 1) 2)
	-25		+40		CLP HC	VG 320	Tribol 1510/320	
	-20		+40		CLP	VG 220	Food Proof 1810/220	
	-20		+50	3)	CLP PG	VG 460		Food Proof 1800/460 1) 2)

Roller bearing grease

The roller bearings on Lenze motors and gearboxes are filled with the following greases in the factory:

	Ambient temperature	Manufacturer	Type
Gearbox roller bearings GST, GFL, GKS, GKR	-30 ... +50 °C -30 ... +80 °C -40 ... +60 °C	Fuchs Klüber Klüber	Renolit H 443 Petamo 133N Microlube GHY 72
Gearbox roller bearings GSS	-30 ... +80 °C -15 ... +60 °C	Klüber Klüber	Petamo 133N Klüberplex BE 11-462
Motor roller bearings	-30 ... +70 °C	Lubcon	Thermoplex 2TML
	-40 ... +80 °C	Klüber	Asonic GHY 72
Special greases for gearbox roller bearings			
Low-temperature grease, note critical starting performance at low temperatures	-40 ... +80 °C	Klüber	Asonic GHY 72
Bio grease (lubricant for forestry, farming and water management)	-40 ... +50 °C	Fuchs	Plantogel 0120S



General data

Standards	The motors meet the requirements of applicable DIN and IEC standards EC conformance to Low Voltage Directive
Operating mode	Designed for duty cycle S1 (continuous operation with constant load at rated power)
Enclosure	IP55 (self-ventilated)
Thermal class (EN 60034)	Insulation system to thermal class F Utilisation to thermal class B
Insulation resistance	Maximum voltage amplitude $\hat{U} = 1.5 \text{ kV}$ Maximum rate of voltage rise $du/dt = 5 \text{ kV}/\mu\text{s}$
Temperature monitoring	Temperature sensor (NC contact)
Temperature range	-20 ... +40°C without power derating
Installation height	Up to 1000 m amsl without power derating
Terminal box	Motor connection to terminal board, accessory connections on terminal block, brake rectifier can be integrated into terminal box
Bearing	Deep-groove ball bearing with 2 caps

Drive dimensioning

4-pole motor versions

Basic versions

Motor frame size	063		071	080	090	100	112	132	160	180	200	225
Versions												
4-pole	063C02 063C22	063C12 063C32 063C42	071C32 071C42	080C32 080C42	090C32	100C12 100C32	112C22 112C32	132C22 132C32	160-22 160-32	180-22 180-32	200N32	225N12 225N22
Mech. integrated into Lenze gearbox	▲	▲	▲	▲	▲	▲	▲	▲	▲	▲		
Cooling												
Integral fan		▲	▲	▲	▲	▲	▲	▲	▲	▲	▲	▲
Self-ventilated	▲											
Enclosure												
IP 55	▲	▲	▲	▲	▲	▲	▲	▲	▲	▲	▲	▲
Motor protection												
Thermal class F	▲	▲	▲	▲	▲	▲	▲	▲	▲	▲	▲	▲
Temperature sensor: thermal contact (NC contact)	▲	▲	▲	▲	▲	▲	▲	▲	▲	▲	▲	▲
Motor connection												
Terminal box	▲	▲	▲	▲	▲	▲	▲	▲	▲	▲	▲	▲

Options (note possible combinations)

Cooling												
Separate fan	Not required for inverter operation	▲	▲	▲	▲	▲	▲	▲	▲	▲	▲	▲
Motor protection												
Temperature sensor PTC thermistor	PTC	PTC	PTC	PTC	PTC	PTC	PTC	PTC	PTC	PTC	PTC	PTC
Continuous temperature sensor	KTY	KTY	KTY	KTY	KTY	KTY	KTY	KTY	KTY	KTY	KTY	KTY
Motor connection												
starttec motor starter		▲ ¹⁾	▲	▲	▲	▲	▲					
ICN connector (motor without additional options)	▲	▲	▲	▲	▲	▲	▲					
Holding systems												
Spring-operated brake Mains or 24 V DC connection	▲	▲	▲	▲	▲	▲	▲	▲	▲	▲	▲	▲
Speed/position encoder												
Resolver	▲	▲	▲	▲	▲	▲	▲	▲	▲	▲		
Incremental encoder	▲	▲	▲	▲	▲	▲	▲	▲	▲	▲		
Additional options												
Increased centrifugal mass (cast iron fan)			▲	▲	▲	▲	▲	▲				
Handwheel			▲	▲	▲	▲	▲	▲				
Condensation drain hole	▲	▲	▲	▲	▲	▲	▲	▲	▲	▲	▲	▲
Protection cover for integral fan			▲	▲	▲	▲	▲	▲	▲			
Protection cover for separate fan		▲	▲	▲	▲	▲	▲	▲	▲			
2nd shaft end (acc. to definition)			▲	▲	▲	▲	▲	▲				

¹⁾ Only for motor frame size 063C42



Possible combinations for options

Possible combinations	Motor frame size	063C02	063C12	071C32	080C32	090C32	100C12	112C22	132C22	160-22	180-22	200N32	225N12
		063C22	063C32 063C42	071C42	080C42		100C32	112C32	132C32	160-32	180-32		225N22
Separate fan			▲	▲	▲	▲	▲	▲	▲	▲	▲	▲	▲
Brake		▲											
Brake + integral fan			▲	▲	▲	▲	▲	▲	▲	▲	▲	▲	▲
Brake + separate fan			▲	▲	▲	▲	▲	▲	▲	▲	▲	▲	▲
Brake + centrifugal mass (integral fan)				▲	▲	▲	▲	▲	▲				
Brake + integral fan + handwheel/ 2nd shaft end				▲	▲	▲	▲	▲	▲				
Brake* + speed/pos. encoder			▲										
Brake* + speed/pos. encoder + integral fan			▲	▲	▲ ¹⁾	▲ ¹⁾	▲ ¹⁾	▲ ¹⁾	▲ ¹⁾				
Brake* + speed/pos. encoder + separate fan			▲	▲	▲	▲	▲	▲	▲	▲	▲		
Speed/ position encoder		▲											
Speed/ position encoder + integral fan			▲	▲	▲	▲	▲	▲	▲	▲			
Speed/ position encoder + separate fan			▲	▲	▲	▲	▲	▲	▲	▲	▲		
Integral fan + handwheel/ 2nd shaft end				▲	▲	▲	▲	▲	▲				
Centrifugal mass (integral fan)				▲	▲	▲	▲	▲	▲				
Centrifugal mass + handwheel/ 2nd shaft end (integral fan)				▲	▲	▲	▲	▲	▲				

¹⁾ On request

* Brake in low-noise design

Drive dimensioning

2-pole and 6-pole motor versions

Basic versions

Motor frame size	063	071	080	090	100	112	132
Versions							
2-pole	063-11 063-31	071-11 071-31	080-11 080-31	090-11 090-31	100-31 100-41	112-31 112-41	132-21
6-pole		071-13 071-33	080-13 080-33				
Mech. integrated into Lenze gearbox	▲	▲	▲	▲	▲	▲	▲
Cooling							
Integral fan	▲	▲	▲	▲	▲	▲	▲
Enclosure							
IP 55	▲	▲	▲	▲	▲	▲	▲
Motor protection							
Thermal class F	▲	▲	▲	▲	▲	▲	▲
Temperature sensor: thermal contact (NC contact)	▲	▲	▲	▲	▲	▲	▲
Motor connection							
Terminal box	▲	▲	▲	▲	▲	▲	▲

Options (note possible combinations)

Cooling							
Separate fan	▲	▲	▲	▲	▲	▲	▲
Motor protection							
Temperature sensor PTC thermistor	PTC	PTC	PTC	PTC	PTC	PTC	PTC
Continuous temperature sensor	KTY	KTY	KTY	KTY	KTY	KTY	KTY
Motor connection							
starttec motor starter		▲	▲	▲	▲		
ICN connector (motor without additional options)	▲	▲	▲	▲	▲	▲	
Holding systems							
Spring-operated brake Mains or 24 V DC connection	▲	▲	▲	▲	▲	▲	▲
Speed/position encoder							
Resolver	▲	▲	▲	▲	▲	▲	▲
Incremental encoder	▲	▲	▲	▲	▲	▲	▲
Additional options							
Increased centrifugal mass (cast iron fan)		▲	▲	▲	▲	▲	▲
Handwheel		▲	▲	▲	▲	▲	▲
Condensation drain hole	▲	▲	▲	▲	▲	▲	▲
Protection cover for integral fan		▲	▲	▲	▲	▲	▲
Protection cover for separate fan	▲	▲	▲	▲	▲	▲	▲
2nd shaft end (acc. to definition)		▲	▲	▲	▲	▲	▲



Possible combinations for options

Motor frame size	063-11 063-31	071-11 071-31 071-13 071-33	080-11 080-31 080-13 080-33	090-11 090-31	100-31 100-41	112-31 112-41	132-21
Separate fan	▲	▲	▲	▲	▲	▲	▲
Brake + integral fan	▲	▲	▲	▲	▲	▲	▲
Brake + separate fan	▲	▲	▲	▲	▲	▲	▲
Brake + centrifugal mass (integral fan)		▲	▲	▲	▲	▲	▲
Brake + integral fan + handwheel/ 2nd shaft end		▲	▲	▲	▲	▲	▲
Brake* + speed/pos. encoder + separate fan	▲	▲	▲	▲	▲	▲	▲
Speed/ position encoder + integral fan	▲	▲	▲	▲	▲	▲	▲
Speed/ position encoder + separate fan	▲	▲	▲	▲	▲	▲	▲
Integral fan + handwheel/ 2nd shaft end		▲	▲	▲	▲	▲	▲
Centrifugal mass (integral fan)		▲	▲	▲	▲	▲	▲
Centrifugal mass + handwheel/ 2nd shaft end		▲	▲	▲	▲	▲	▲

* Brake in low-noise design

Configuration aid

Option		Function	Possible applications
Cooling	Separate fan	Operation at rated torque at low speeds	▶ Wide operational speed range with rated torque
Motor protection	Thermal contact NC contact	Protects the motor against thermal overload	▶ Monitoring the motor winding temperature ▶ Switching a motor relay
	Temperature sensor PTC thermistor/PTC	Protects the motor against thermal overload	▶ PTCs operate in conjunction with a control unit ▶ Unlike the thermal contact, can be reset quickly.
	Continuous temperature sensor KTY	Protects the motor against thermal overload	▶ Measuring the temperature of the motor winding
Motor connection	ICN connector	Geared motor connection via a pluggable connector	▶ The motor can be replaced/dismantled more quickly and easily
Holding systems	Spring-operated brake	Brakes the motor	▶ Decelerating loads ▶ Holding loads ▶ Braking torque available in de-energised state
Additional options	Condensation drain hole	Drains condensation	▶ Operation in extreme climatic conditions ▶ Outdoor installation
	Protection cover	Protects against foreign matter falling into the fan cover	▶ Protecting the air inlet opening against foreign matter if the drive is installed vertically with the motor shaft downwards