

405 619

# Lenze

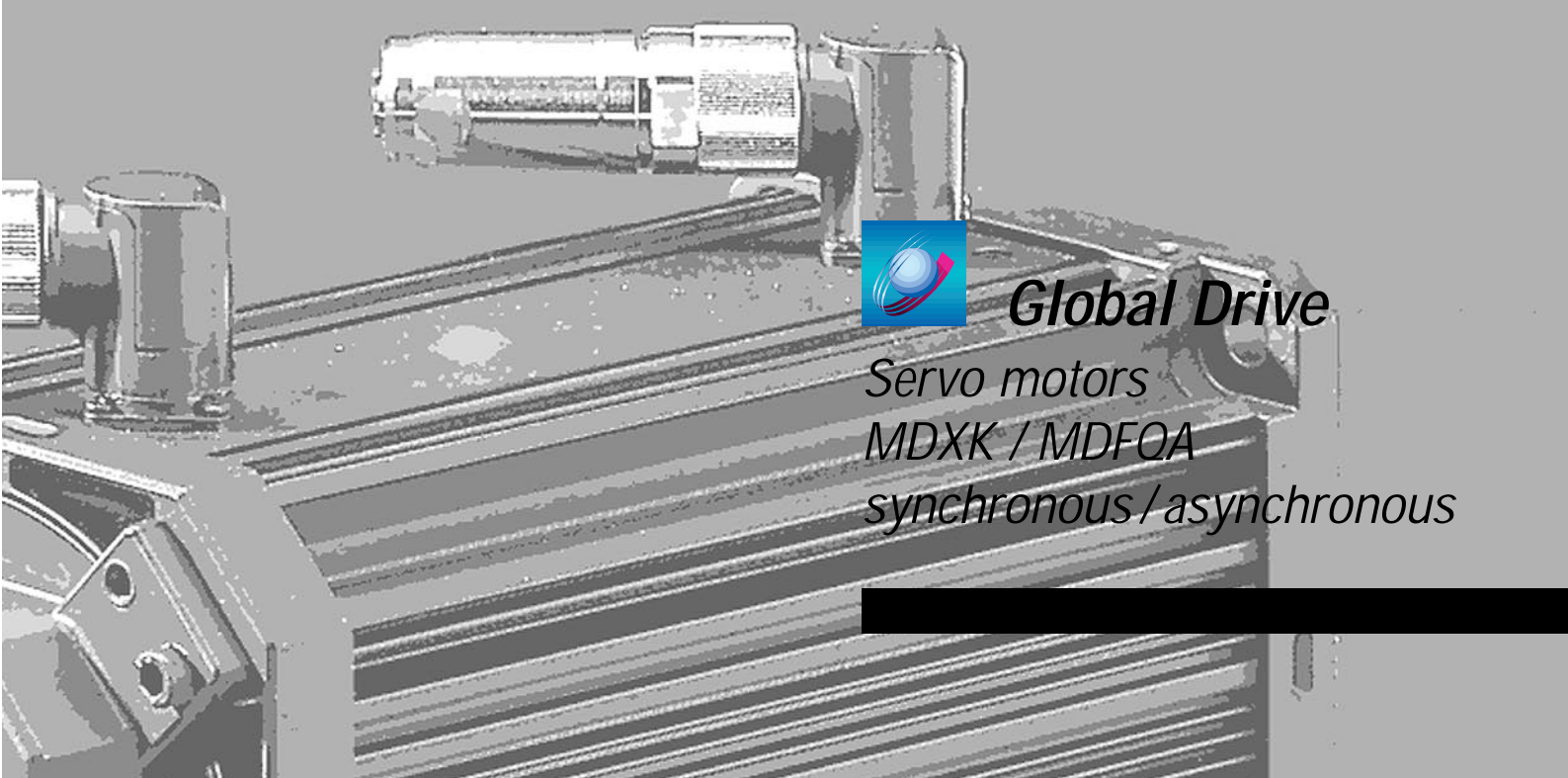
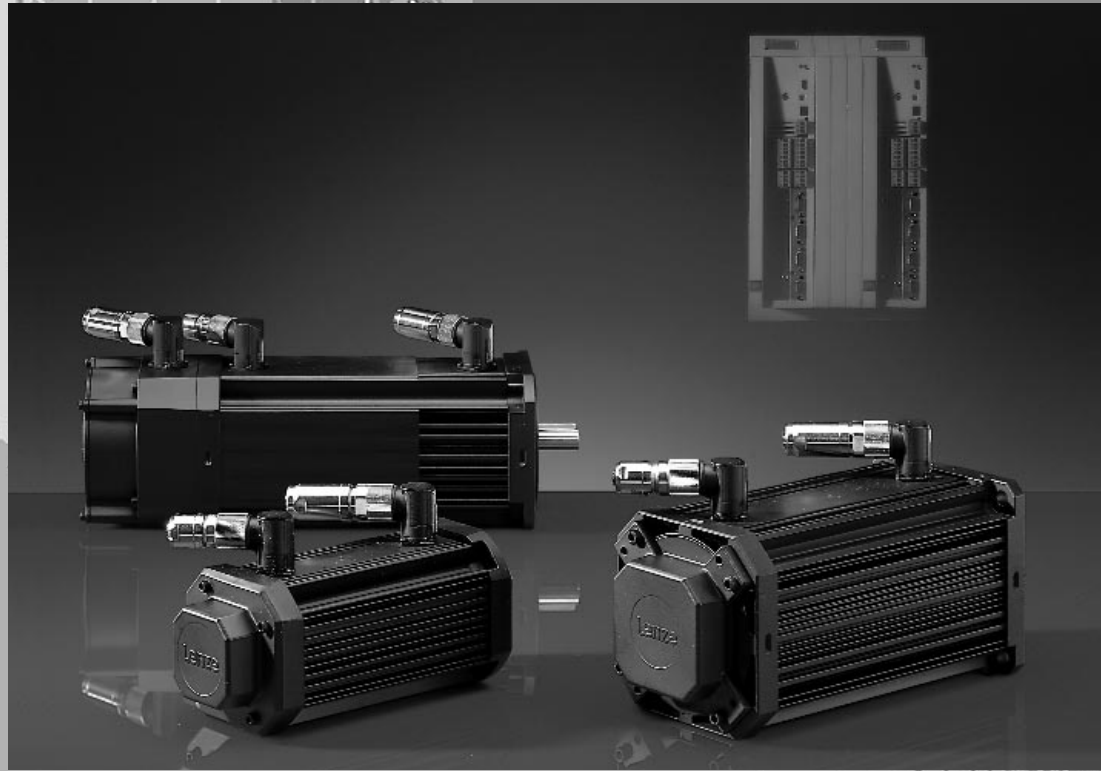

**Global Drive**

*Servo motors*

*MDXK / MDFOA*

*synchronous / asynchronous*

# System overview

## Servo motors

In the Global Drive System, asynchronous and synchronous motors perfectly match the controllers. Thanks to modular design and the planned options it is possible to select a suitable drive. Further assets of Global Drive servo motors are: small size, long life and high operational safety.

Comfortable system cables with plug-in connectors enable easy connection. Modern production processes ensure a good price / performance ratio. This catalogue describes all preference types which are available within 15 working days as well as all industry types which require a delivery time of 30 working days. We would like to present further options of this modular design personally.

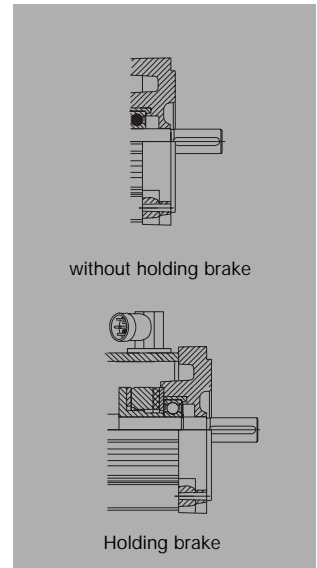
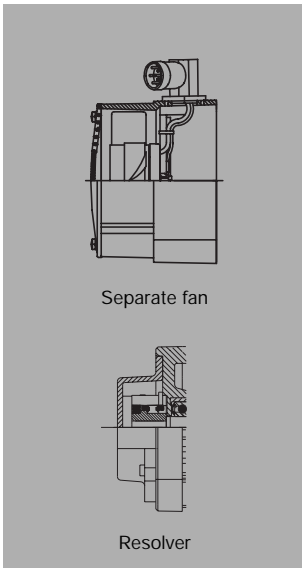

# Product code

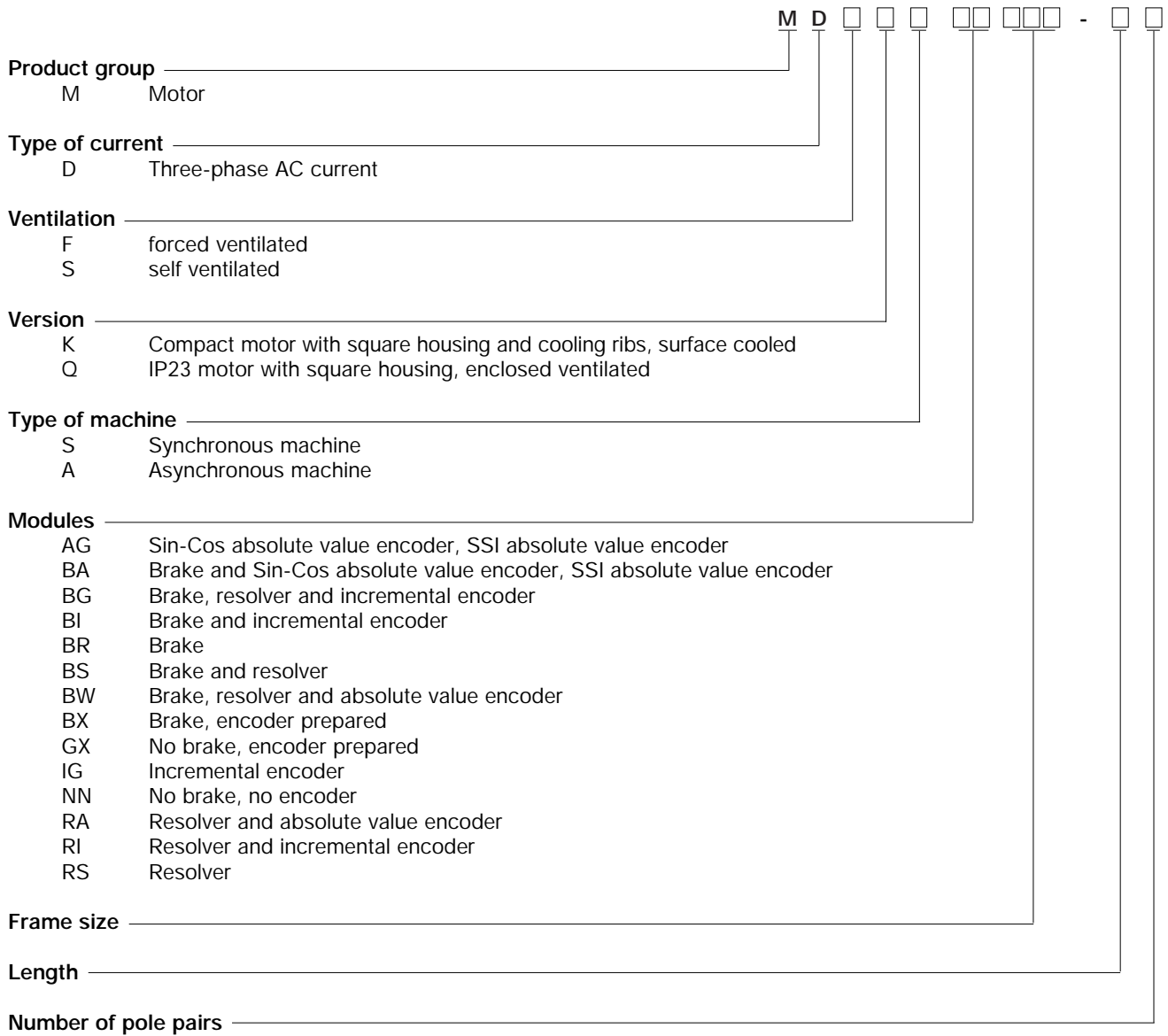

# Global Drive servo motors

## Product information

_____	8
-------	---

## Selection of servo motors

General data _____	9
Preference types _____	10
Rated data MDXKS _____	11
Rated data MDXKA _____	12
Rated data MDFQA _____	13
Torque-limit characteristics _____	14

## Technical data of servo motors

Permissible shaft load _____	38
Fan modules _____	39
Brake modules _____	40
Angle and speed controller modules _____	42
Resolver modules _____	42
SinCos absolute value encoder modules _____	43
Incremental encoder modules _____	43
KTY temperature sensor modules _____	44
Thermostat modules _____	44
Plug-in connectors _____	45
Terminal box _____	48

## Dimensions of servo motors

Synchronous servo motor MDSKS 036 _____	51
Synchronous servo motor MDSKS 056 _____	52
Synchronous servo motor MDXKS 071 _____	53
Asynchronous servo motor MDSKA 056 _____	54
Asynchronous servo motor MDXKA 071 _____	55
Asynchronous servo motor MDXKA 080 _____	56
Asynchronous servo motor MDXKA 090 _____	57
Asynchronous servo motor MDXKA 100 _____	58
Asynchronous servo motor MDXKA 112 _____	59
Asynchronous servo motor MDFQA 100...132 _____	60

## Application examples

Application of a servo controller _____	62
Possible combinations with controllers _____	64
Connection _____	68
EC Directives _____	69

## Order forms

Servo motor MDXK _____	71
Servo motor MDFQA _____	74

## Lenze worldwide

_____	76
-------	----

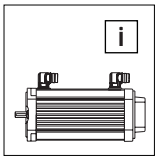

## Product information

### Servo motors MDXK and MDFQA

Today, servo drive systems must fulfil highest demands. With Global Drive, Lenze succeeded in combining different drive components to form a perfectly matching system. The programme of servo motors for the power range up to 60.1 kW is completed by brushless synchronous servo motors for the lower power range from 0.25 to 4.2 kW. Compared with standard three-phase AC motors, these servo motors provide a very low moment of inertia, low weight, high maximum speed and a wide speed-setting range.

#### High dynamic response and accuracy

Servo motors provide a low moment of inertia and a high overloadability. Optimum temperature-independent control features are achieved by continuously measuring the temperature with an integrated temperature sensor. Together with servo inverters of series 9300, the motors ensure high speed accuracy, best concentricity and high angle acceleration.

#### Long service life

The high quality standard, Lenze sets for all components, meets the requirements of modern drive technology for operational safety and service life. A reinforced isolation with thermal reserve (coated wire to thermal class H, class F temperature rise) ensures a long service life of the winding. Prestressed rolling bearings with high temperature resistant lubrication ensure a long service life.

#### Operational safety

Enclosure IP54 of MDXK motors ensures good protection against dust and water ingress. MDFQA motors up to 60.1 kW are protected by enclosure IP23.

#### CE conformity

Of course, Lenze servo motors MDXK and MDFQA comply with the EC Directives:

- CE conformity to the Low Voltage Directive
- CE conformity to the Electromagnetic Compatibility of a typical drive configuration with inverter.

The electromagnetic compatibility can be easily guaranteed by using predetermined system cables.

#### No compromises with the output speed

The wide ratio range of gearboxes combined with the small ratio step of 1.12 enables the exact selection of the output speed range required.

#### Compact

The high power density of the motors facilitates small drive units.

Especially compact drives are formed by using geared servo motors with directly connected motors.

#### Adaptability

The modular motor design and the number of planned variants facilitate the selection of the motor for your application.

Thanks to the variety of output designs of motors and geared motors, the drives fulfil many application requirements:

- Servo motors with cylindrical shaft end with or without key
- Servo motors with flanges provided with through hole bores for mounting position B5, with threaded bores for mounting position B14.
- Geared servo motors with solid shaft, hollow shaft or hollow shaft with shrink disc.
- Geared servo motors with or without flange, foot or centring
- Different integrated angle encoders ensure the accuracy required:
  - Resolver as standard solution, optimised characteristic because of internal improvement of the resolver accuracy. SinCos absolute value encoder as industry type for highest accuracy. Incremental encoder with 2048 pulses as preference type for MDFQA and as industry type for MDXK.

#### Low noise

High chopper frequency of the inverters (up to 16 kHz) result in a low noise generation.

In addition, optimised tooth geometry and internally ribbed cast iron housings of Lenze Gearboxes reduce the noise generated.

#### Reduced backlash

The application of backlash-free permanent magnet holding brakes enables a defined holding of a position even when no voltage is applied.

Compared with other gearboxes, backlash-free connection elements of Lenze Gearboxes and the high splining quality achieved by precise production ensure a low backlash at the output of geared servo motors.

#### Special types

Special applications require special motor designs.

Possible options are e.g.:

- incremental encoder as feedback with 4096 pulses
- second feedback.

We are prepared to give more detailed information.

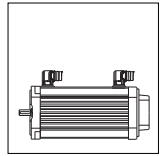

	Synchronous servo motors Series MDSKS, MDFKS	Asynchronous servo motors Series MDSKA, MDFKA	Asynchronous servo motors MDFQA
Enclosure	IP54 / IP65		IP23
Thermal class (VDE 0530)	To thermal class F Insulation (coated wire) To thermal class H		
UL-conformity	UL listed material for coated wire, brush leads, insulation material		
Dielectric strength	Max. voltage amplitude $\hat{V} = 1.5 \text{ kV}$ Max. rate of voltage rise $du/dt = 5 \text{ kV}/\mu\text{s}$		
Vibrational severity	N	N frame sizes 056 and 071, R as of frame size 80	N
Concentricity, eccentricity, coaxiality (DIN 42955)	N	N frame sizes 056 and 071, R as of frame size 80	N
Mechanical tolerance	Diameter shaft end d $\varnothing 11$ to $\varnothing 38$ : k6, d $\varnothing 55$ : m6 Diameter centring flange b1 : J6		
Temperature monitoring (no complete protection)	Continuous temperature sensor (KTY 83-110)		
Connection	1 plug for each: Motor and brake Resolver and temperature sensor, separate fan (as of frame size 071) or terminal box		Motor connection as terminal box, encoder connection with plug
Temperature range	-20 to + 40 °C without power derating (without brake, non-ventilated) -10 to + 40 °C without power derating (with brake) -15 to +40 °C without power derating (separately ventilated)		
Surface temperature	Self ventilated motors (MDSK) up to 140 °C Forced ventilated motors (MDFK) up to 110 °C		to 110 °C
Installation height	up to 1000 m a. m. s. l. without power derating		
Demagnetising limit	> 4 · I <sub>rated</sub> with self ventilation > 2,9 · I <sub>rated</sub> with forced ventilation	Demagnetisation not possible	
Maximum torque	> 4 · M <sub>rated</sub> with self ventilation > 2,9 · M <sub>rated</sub> with forced ventilation	> 5 · M <sub>rated</sub>	
Rated speed	3000 min <sup>-1</sup>	1635-4160 min <sup>-1</sup>	550-2935 min <sup>-1</sup>
Angle encoder	Resolver / Sin-Cos encoder	Resolver / incremental encoder / Sin-Cos absolute value encoder	
Mounting position	B5 / B14		B5 / B35
Bearing	Deep groove ball bearing with high-temperature resistant grease, 2 seals		
	Locating bearing at A-side		at B-side
Shaft end	with / without key		
Brake	with or without permanent magnet holding brake at A-side		with and without spring- operated brake
Fan	Axial fan as of frame size 071 possible		Radial fan
Colour	Black, RAL 9005		



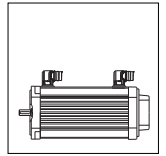

### Synchronous servo motors series MDSKS / MDFKS (surface cooled)

Motor type	Axial height h [mm]	Torque with 3000/min M <sub>rated 3000</sub> [Nm]	Speed n <sub>rated</sub> [min <sup>-1</sup> ]	Torque M <sub>rated</sub> [Nm]	Power P <sub>rated</sub> [kW]	Voltage V <sub>rat. 3-</sub> [V]	Current I <sub>rated</sub> [A]	M <sub>0</sub> [Nm]	I <sub>0</sub> [A]	Maximum torque <sup>6)</sup> M <sub>max</sub> [Nm]	Maximum power I <sub>max</sub> [A]	Frequency f <sub>rated</sub> [Hz]	Inertia J [kgcm <sup>2</sup> ]	Weight m <sup>1)</sup> [kg]	Gearbox connection corresp. to stand. motor d x l <sup>3)</sup>
without fan															
MDSKS 036-13, 200	35		4000	0.6	0.25	245	0.9	0.65	0.9	3.1	5.4	200	0.22	1.5	
MDSKS 036-23, 200	35		4000	1.3	0.54	345	1.1	1.5	1.25	7.2	7.5	200	0.36	2.1	
MDSKS 056-23, 190	51	2.9	3800	2.8	1.1	330	2.3	3.2	2.6	11.6	10	190	1.2	5.3	071, C105
MDSKS 056-33, 200	51	4.3	4000	4.2	1.8	325	3.6	4.7	4.0	17.2	16	200	1.8	6.3	071, C105
MDSKS 071-03, 170	65	5.9	3400	5.7	2.0	330	4.2	6.7	4.9	23.6	19	170	6.0	8.9	080, C160
MDSKS 071-13, 185	65	8.8	3700	8.3	3.2	325	7.0	10.0	8.4	35.2	32	185	8.0	10.9	080, C160
MDSKS 071-33, 180	65	12.7	3600	12.3	4.6	325	10.0	14.7	11.9	52.0	45	180	10.0	13.0	080, C160
with separate fan															
MDFKS 071-03, 165	65	7.7	3300	7.5	2.6	330	5.6	8.8	6.6	23.6	19	165	6.0	10.2	080, C160
MDFKS 071-13, 180	65	11.7	3600	11.0	4.1	325	9.2	13.3	11.1	35.2	32	180	8.0	12.2	080, C160
MDFKS 071-33, 175	65	17.0	3500	16.2	5.9	325	13.1	19.3	15.6	52.0	45	175	10.0	14.3	080, C160

1) without fan, with resolver

3) frame size and flange of a standard motor with similar flange and shaft dimensions

6) magnetic / mechanical permissible torque

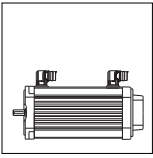

# Selection

## Rated data

### Asynchronous servo motors series MDSKA / MDFKA (surface ventilated)

Motor type	h [mm]	n <sub>rated</sub> [min <sup>-1</sup> ]	M <sub>rated</sub> [Nm]	P <sub>rated</sub> <sup>5)</sup> [kW]	V <sub>rated</sub> <sup>3)</sup> [V]	I <sub>rated</sub> [A]	M <sub>0</sub> [Nm]	I <sub>0</sub> [A]	M <sub>max</sub> <sup>6)</sup> [Nm]	n <sub>rated max</sub> [min <sup>-1</sup> ]	f <sub>rated</sub> [Hz]	cosφ <sub>N</sub>	J <sup>1)</sup> [kgcm <sup>2</sup> ]	m <sup>1)</sup> [kg]	Gearbox connection corresponds to standard motor <sup>3)</sup>
self cooled															
MDSKA 056-22, 140	51	3950	2.0	0.8	390	2.4	2.3	2.55	10	8000	140	0.70	2.4	6.4	071, C105
MDSKA 071-22, 140	65	4050	4.0	1.7	390	4.4	4.6	4.6	32	8000	140	0.76	8.3	10.4	080, C160
MDSKA 080-22, 70	71	2000	6.7	1.4	390	3.3	8.0	3.85	60	8000	70	0.75	19.2	15.1	090, C160
MDSKA 080-22, 140		4100	5.4	2.3	390	5.8	8.0	7.7	60	8000	140	0.75			
MDSKA 090-22, 80	83	2300	10.8	2.6	390	5.5	12.8	6.0	100	8000	80	0.81	36	22.9	090, C160
MDSKA 090-22, 140		4110	9.5	4.1	350	10.2	12.8	12.0	100	8000	140	0.80			
MDSKA 100-22, 80	96	2340	16.3	4.0	390	8.2	22.5	9.85	180	8000	80	0.80	72	44.7	112, C160
MDSKA 100-22, 140		4150	12.0	5.2	330	14.0	22.5	19.7	180	8000	140	0.78			
MDSKA 112-22, 85	107	2490	24.6	6.4	390	13.5	39	15.9	300	8000	85	0.83	180	60	132, A300
MDSKA 112-22, 140		4160	17.0	7.4	320	19.8	39	31.8	300	8000	140	0.80			
with separate fan															
MDFKA 071-22, 120	65	3410	6.3	2.2	390	6.0	7.0	6.3	32	8000	120	0.75	8.3	12.0	080, C160
MDFKA 080-22, 60	71	1635	12.0	2.1	390	4.8	13.5	5.25	60	8000	60	0.81	19.2	16.9	090, C160
MDFKA 080-22, 120		3455	10.8	3.9	390	9.1	13.5	10.5	60	8000	120	0.80			
MDFKA 090-22, 60	83	1680	21.5	3.8	390	8.5	23.9	9.05	100	8000	60	0.80	36	25.5	090, C160
MDFKA 090-22, 120		3480	19.0	6.9	390	15.8	23.9	18.1	100	8000	120	0.80			
MDFKA 100-22, 60	96	1700	36.3	6.4	390	13.9	40.0	15.4	180	8000	60	0.83	72	48.2	112, C160
MDFKA 100-22, 120		3510	36.0	13.2	390	28.7	40.0	30.8	180	8000	120	0.80			
MDFKA 112-22, 60	107	1710	61.4	11.0	390	22.5	75	25.8	300	8000	60	0.85	180	63.5	132, A300
MDFKA 112-22, 120		3520	55.0	20.3	390	42.5	75	49.5	300	8000	120	0.80			

1) without brake, with resolver

2) with 390 V, idle running M = 0

3) frame size and flange of a standard motor with similar flange and shaft dimensions

5) when V<sub>rated</sub> · P = P<sub>rated</sub> up to 2.3 · n<sub>rated</sub>

6) magnetic / mechanical permissible torque



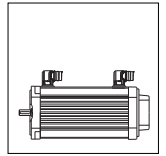

### Asynchronous servo motors series MDFQA (enclosed ventilated)

Motor type	Connec- tion	h [mm]	n <sub>rated</sub> [min <sup>-1</sup> ]	M <sub>rated</sub> [Nm]	P <sub>rated</sub> <sup>5)</sup> [kW]	V <sub>rated</sub> <sup>3)</sup> [V]	I <sub>rated</sub> [A]	M <sub>0</sub> [Nm]	I <sub>0</sub> [A]	M <sub>max</sub> <sup>6)</sup> [Nm]	f [Hz]	η	cosφ	n <sub>max</sub> [min <sup>-1</sup> ]	J <sup>1)</sup> [kgcm <sup>2</sup> ]	m <sup>1)</sup> [kg]	Gearbox connection corresponds to standard motor 3)
MDFQA 100-22, 50	Y	100	1420	71.3	10.6	360	26.5	76	27.0	250	50	0.76	0.84	5000	180	65	132, A300
MDFQA 100-22, 100	Y	100	2930	66.2	20.3	360	46.9	76	54.0	250	100	0.87	0.80				
MDFQA 112-22, 50	Y	112	760	145	11.5	360	27.2	156	29.5	500	28	0.78	0.87	4500	470	115	132, A300
	Δ		1425	135	20.1	360	43.7	156	51.0	500	50	0.86	0.86				
MDFQA 112-22, 100	Y	112	1670	130	22.7	360	49.1	156	59.0	500	58	0.87	0.85				
	Δ		2935	125	38.4	360	81.9	156	102.0	500	100	0.90	0.83				
MDFQA 132-32, 36	Y	132	550	296	17.0	360	45.2	325	52.6	1100	20	0.74	0.81	4500	1310	170	200, A400
	Δ		1030	288	31.1	360	77.4	325	90.2	1100	36	0.84	0.77				
MDFQA 132-32, 76	Y	132	1200	282	35.4	360	88.8	325	109.0	1100	42	0.82	0.78				
	Δ		2235	257	60.1	340	144.8	325	196.5	1100	76	0.88	0.80				

- 1) without brake, with resolver
- 2) with 390 V, idle running M = 0
- 3) frame size and flange of a standard motor with similar flange and shaft dimensions
- 5) when V<sub>rated</sub> · P = P<sub>rated</sub> up to 2.3 · n<sub>rated</sub>
- 6) magnetic / mechanical permissible torque

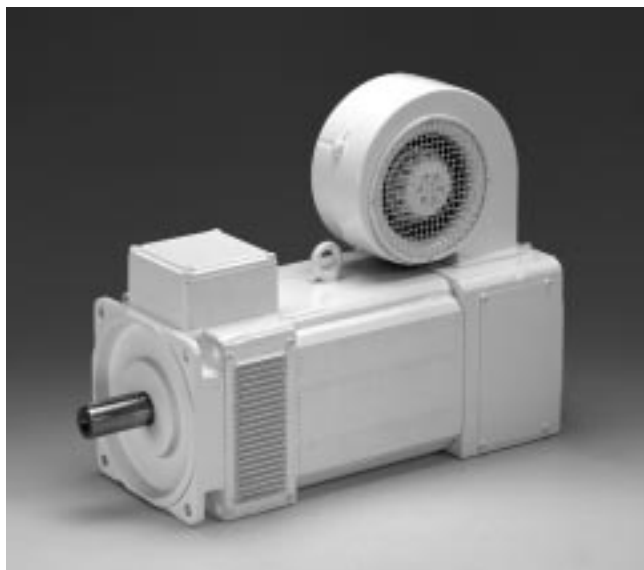



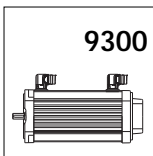

9300

## Technical data

### Rated data

#### Permissible shaft load

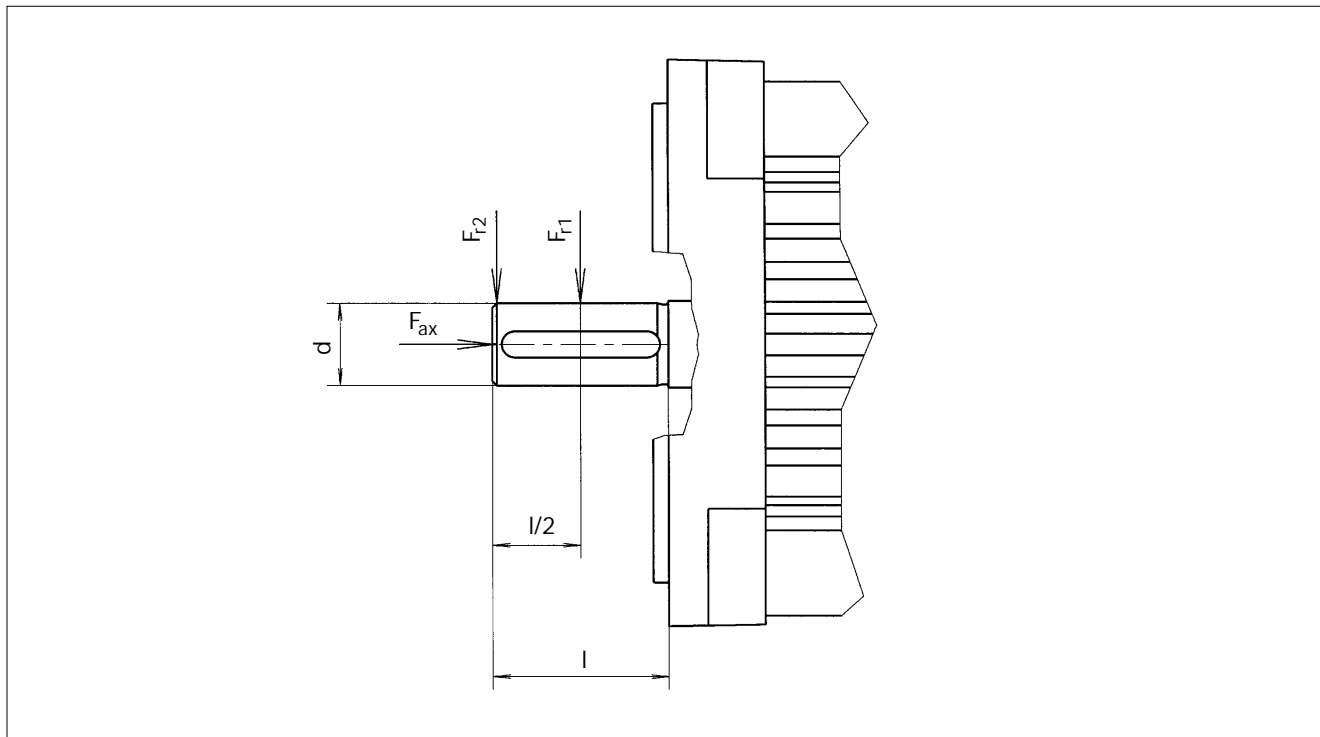

#### Series MDXKX (surface ventilated)

Motor type	d x l [mm]	F <sub>a</sub> [N]	F <sub>r1</sub> [N]	F <sub>r2</sub> [N]
MDXKS 036	11 x 23	70	250	180
MDXKX 056	14 x 30	100	330	250
MDXKX 071	19 x 40	150	600	400
MDXKX 080	24 x 50	200	700	600
MDXKX 090	24 x 50	260	1000	900
MDXKX 100	28 x 60	500	1500	1400
MDXKX 112	38 x 80	700	2000	1700

#### Series MDFQA (enclosed ventilated)

Motor type	d x l [mm]	F <sub>a</sub> [N]	F <sub>r1</sub> [N]	F <sub>r2</sub> [N]
MDFQA 100	38 x 80	900	2300	1000
MDFQA 112	38 x 80	1300	2300	1350
MDFQA 132	55 x 110	3500	4950	3580

Calculation basis:

Bearing life:  $L_{h10} = 20.000$  h, torque  $M = 2.5 M_{rated}$

Linear interpolation between  $F_{r1}$  and  $F_{r2}$  possible.

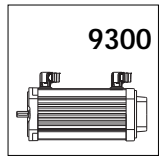

Fans

Motor type	Fan type	$V_{rated}$ [V]	$f_{rated}$ [Hz]	$I_{rated}$ [A]	$P_{rated}$ [W]
MDFK 071		210...240, 1~	50/60	0.12	19
MDFK 080		210...240, 1~	50/60	0.12	19
MDFK 090		210...240, 1~	50/60	0.32	46
MDFK 100		210...240, 1~	50/60	0.32	46
MDFK 112		210...240, 1~	50/60	0.26	60
MDFQA 100	G2D 120	380...460, 3~	50/60	0.11	60
MDFQA 100	G2D 140 with filter	380...460, 3~	50/60	0.25	150
MDFQA 100	DNG 3-4,5 with or without filter with large voltage range	350...540, 3~	50/60	0.25	100
MDFQA 112	G2D 160 with filter	380...460, 3~	50/60	0.5	320
MDFQA 112	DNG 5-12,5 with or without filter with large voltage range	350...540, 3~	50/60	0.75	390
MDFQA 132	G2D 180	380...460, 3~	50/60	0.66	415
MDFQA 132	DNG 8-12 with or without filter with large voltage range	350...540, 3~	50/60	1.4	660

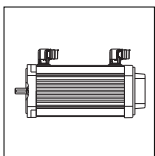

## Technical data

### Attachments

#### Brake

The servo motors MDXKX can be equipped with integrated permanent magnet holding brakes for 24 V DC (industrial type 205 V).

The enclosed ventilated asynchronous servo motors MDFQA can be equipped with a 205 V or 24 V spring operated brake.

The brakes are active after switching off the power supply (normally on principle).

When using the brakes for holding applications only, the friction linings are virtually resistant to wear. If the permissible friction work is not exceeded, at least 150 emergency stop operations are possible.

Motor type	$M_B$ [Nm]	$V_{rated\ 24}$ [V]	$I_{24}$ [A]	$V_{rated\ 205}$ [V]	$I_{205}$ [A]
<b>MDSKXBX 036</b>	2.5	24 (+5%, -10%)	0.50	205 (+5%, -10%)	0.06
<b>MDSKXBX 056</b> with direct gearbox connection	2.5 5	24 (+5%, -10%) 24 (+5%, -10%)	0.50 0.67	205 (+5%, -10%) 205 (+5%, -10%)	0.06 0.08
<b>MDXKXBX 071</b> with direct gearbox connection	10 12	24 (+5%, -10%) 24 (+5%, -10%)	0.67 0.75	205 (+5%, -10%) 205 (+5%, -10%)	0.08 0.09
<b>MDXKABX 080</b> with direct gearbox connection	12 20	24 (+5%, -10%) 24 (+5%, -10%)	0.75 1.00	205 (+5%, -10%) 205 (+5%, -10%)	0.09 0.12
<b>MDXKABX 090</b> with direct gearbox connection	20 20	24 (+5%, -10%) 24 (+5%, -10%)	0.75 1.00	205 (+5%, -10%) 205 (+5%, -10%)	0.09 0.12
<b>MDXKABX 100</b> with direct gearbox connection	40 40	24 (+5%, -10%) 24 (+5%, -10%)	1.00 1.46	205 (+5%, -10%) 205 (+5%, -10%)	0.12 0.18
<b>MDXKABX 112</b> with direct gearbox connection	80 80	24 (+5%, -10%) 24 (+5%, -10%)	1.46 1.46	205 (+5%, -10%) 205 (+5%, -10%)	0.18 0.18
<b>MDFQABX 100</b>	80 150	24 (+5%, -10%) 24 (+5%, -10%)	2.29 3.54	205 (+5%, -10%) 205 (+5%, -10%)	0.27 0.41
<b>MDFQABX 112</b>	150 240	24 (+5%, -10%) 24 (+5%, -10%)	3.54 4.17	205 (+5%, -10%) 205 (+5%, -10%)	0.41 0.49
<b>MDFQABX 132</b>	240 360	24 (+5%, -10%) 24 (+5%, -10%)	4.17 4.58	205 (+5%, -10%) 205 (+5%, -10%)	0.49 0.54

The employed brakes are no safety brakes in the real sense of the word, i.e. in case of disruption by not influencable factors, like penetration of oil or failure of the A-side shaft seal, a reduction of torque may occur.

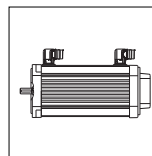

Motor type	t <sub>1</sub> , t <sub>is</sub> <sup>1)</sup> [ms]	t <sub>2</sub> , t <sub>auf</sub> [ms]	Q <sub>E</sub> <sup>2)</sup> [kJ]	S <sub>nü</sub> <sup>3)</sup> [1/h]	J <sub>B</sub> [kgcm <sup>2</sup> ]	m [kg]
<b>MDSKXBX 036</b>	8	18	3.2	31	0.38	0.85
<b>MDSKXBX 056</b> with direct gearbox connection	8 13	18 22	3.2 6.5	31 23	0.38 1.06	0.85 0.75
<b>MDXKXBX 071</b> with direct gearbox connection	20 24	29 30	6.5 12.0	23 17	1.06 3.60	0.83 1.38
<b>MDXKABX 080</b> with direct gearbox connection	24 28	30 55	12.0 25.0	17 12	3.60 3.60	1.45 1.45
<b>MDXKABX 090</b> with direct gearbox connection	25 28	50 55	12.0 25.0	17 12	3.60 9.50	1.54 2.42
<b>MDXKABX 100</b> with direct gearbox connection	28 40	73 100	25.0 50.0	12 9	9.50 31.80	2.72 4.79
<b>MDXKABX 112</b> with direct gearbox connection	53 53	97 97	50.0 50.0	9 9	31.80 31.80	4.98 4.98
<b>MDFQABX 100</b>	90 110	180 300	37 60	27 20	15.00 29.00	13.5 20
<b>MDFQABX 112</b>	110 200	300 400	60 80	20 19	29.00 73.00	21.5 31
<b>MDFQABX 132</b>	200 270	400 500	80 120	19 17	73.00 200.00	32.5 46

- 1) Engagement time for DC switching, for AC switching t<sub>is</sub> prolonged by approx. factor 4  
 2) Max. friction work per switching operation with n = 1500 min<sup>-1</sup>  
 3) Transference operating frequency to VDI 2241 to detect the permissible operating frequency or friction work

With long motor cables and especially with 24V brakes, the ohmic voltage drop along the cable must be observed and compensated by a higher voltage input – otherwise, the voltage applied to the brake will not be high enough (24V or 205V).

For Lenze system cables the following applies:

$$\Delta V_B = 0.08 \cdot l_{\text{cable}} [\text{m}] \cdot I_B [\text{A}]$$

If the voltage applied to the brake is not correct (too high, too low, wrong polarity), the brake is activated immediately and can be overheated and destroyed by the still rotating motor.

Shortest switching times of the brake can be reached by DC switching of the voltage. A spark suppresser avoids voltage peaks.

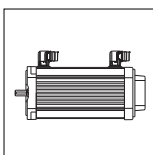

## Technical data

### Attachments

#### Angle and speed encoder for servo motors MDXK and MDXQ

Encoder	Resolver	Incremental encoder	Sin-Cosen encoder single turn	Sin-Cos encoder multi turn
Available for				
Synchronous servo motor MDXKS	●		●	●
Asynchronous servo motor MDXKA (surface cooled)	●	●	●	●
Asynchronous servo motor MDXQA (enclosed ventilated)	●	●	●	●
Designation	RS	IT2048	AS512	AM512
Type		ITD21	SCS70	SCM70
Signals		2048 bars TTL signals	512 periods, sine signals 1 V <sub>ss</sub> asynchronous half-duplex interface RS485 for transmission of the absolute position	
Resolution	0.8'	2.6'	0.4'	0.4'
Accuracy	+ - 10' bzw. + - 4' when entering the correction code	+ - 2' depending on no. of bars	+ - 0.8'	+ - 0.8'
Absolute positioning	1 revolution	no	1 revolution	4096 rev.
Note	<b>Standard solution</b> for most applications	Incremental encoder instead of resolver	Sin-Cos encoder instead of resolver current position via interface of the 9300. Operation only possible after encoder selection at 9300 (encoder type and voltage supply), values saves, and unit switched off and on again.	

#### Resolver (built-in encoder)

Stator-fed resolver with 2 stator windings turned by 90° and a rotor winding with transformer winding.

Design	Brushless hollow shaft resolver in pancake-design	
Max. speed (permanent)	8000 min <sup>-1</sup>	
Max. speed (short time)	10000 min <sup>-1</sup>	
Input voltage	10 V amplitude	
Input frequency	4 kHz	
Ratio stator / rotor	0.3 ± 5 %	
Rotor impedance	Z <sub>ro</sub>	51Ω + j90 Ω
Stator impedance	Z <sub>s0</sub>	102 Ω + j150 Ω
Impedance	Z <sub>rs</sub>	44 Ω + j76 Ω
Insulation resistance	> 10 MΩ with 500 V DC	
No. of pole pairs	1	
Max. phase error	± 10 angular minutes	



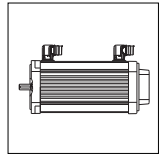

### Sin-Cos absolute value encoder (built-in encoder)

Absolute value encoder with 2 sine-wave signals displaced by 90° with 512 periods per revolution and serial interface RS 485 for the transmission of

parameters and the absolute position within one or 4096 revolutions.

Type	SCS 70
Design	Brushless hollow shaft encoder
Maximum torque	12000 min <sup>-1</sup>
No. of revolutions absolutely resolved	1 (single turn)
No. of periods	512 periods / rev.
Output signals	2 sine-wave signals displaced by 90° with 1 V <sub>SS</sub> , serial interface RS 485, asynchronous, half duplex
Limit frequency	100 kHz
Voltage supply	7 ... 12 V
Current consumption	100 ... 130 mA

Type	SCM 70
Design	Brushless hollow shaft encoder
Maximum torque	12000 min <sup>-1</sup>
No. of revolutions absolutely resolved	4096 (multi turn)
No. of periods	512 periods / rev.
Output signals	2 sine-wave signals displaced by 90° with 1 V <sub>SS</sub> , serial interface RS 485, asynchronous, half duplex
Limit frequency	100 kHz
Versorgung	7 ... 12 V
Current consumption	100 ... 130 mA

### Incremental encoder (built-in encoder)

Encoder with 2 TTL square-wave signals displaced by 90° with 2048 pulses per revolution and additional zero track.

This encoder is optionally available as preference feedback to the resolver for motor series MDFQA.

Type	ITD 21
Design	Brushless hollow shaft encoder
Maximum torque	8000 min <sup>-1</sup>
No. of pulses	2048 pulses / rev.
Output signals	2 square-wave signals displaced by 90°, zero pulse, complementary TTL signals, V <sub>low</sub> ≤ 0.5 V, V <sub>high</sub> ≥ 2.5 V
Voltage supply	5 V ± 5 %, protect against polarity reversal
Current consumption	≤ 150 mA
Limit frequency	300 kHz

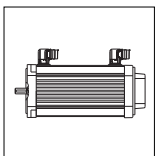

## Technical data

### Attachments

#### Temperature sensor KTY 83-110 (integrated)

The KTY temperature sensor continuously measures the motor temperature. It represents, though, no complete protection. The signals are fed back to the servo inverter

9300 via the system feedback cable. When feeding the encoder with a measuring current of 1 mA, temperature and resistance show the following characteristic:

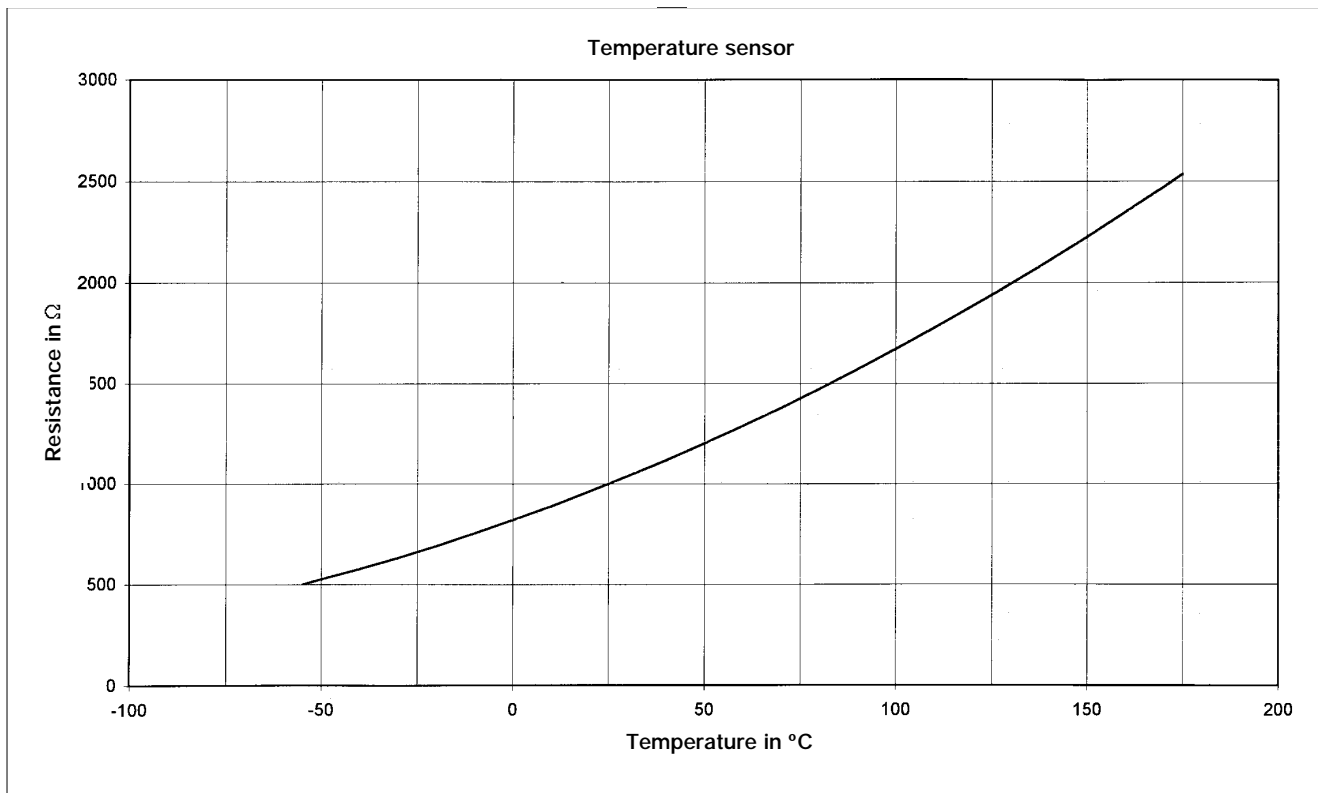

#### Temperature switch – normally closed contact

As alternative to the continuous sensor KTY, with the MDFQA it is also possible to use a temperature contact to monitor the windings.

Asynchronous motors of the series MDFQA are equipped with both temperature monitoring.

#### Technical data

	AC connection	DC connection		
Release temperature		150 °C ± 5 °C		
Reset temperature		90 ... 135 °C		
Connection voltage	250 V ≈	60 V	48 V	24 V
Rated current [A]	2.5 A	1.0 A	1.25 A	1.6 A

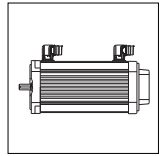

### Plug-in connectors for motor connection

#### Power connection, brake connection

	Pin no.	Terminal designation
Holding brake +UB	1	Y1
Holding brake -UB	2	Y2
Earth PE	⊕	⊕
Motor power phase U	4	1, U1
Motor power phase V	5	2, V1
Motor power phase W	6	3, W1
<b>Global Drive system cables</b>		
Standard cable	EWLMxxxGM-015C MDXK036...090	
	EWLMxxxGM-025 MDXK036...090	
	EWLMxxxGM-040 MDXKA100...112	
	EWLMxxxGM-100 MDXKA100...112	
Trailing cable	EWLMxxxGMS025 MDXKA036...090	
	EWLMxxxGMS040 MDXKA100...112	
Intermediate cable	EWLMxxxZM-015 MDXKA036...090	

#### MDXK 036...090

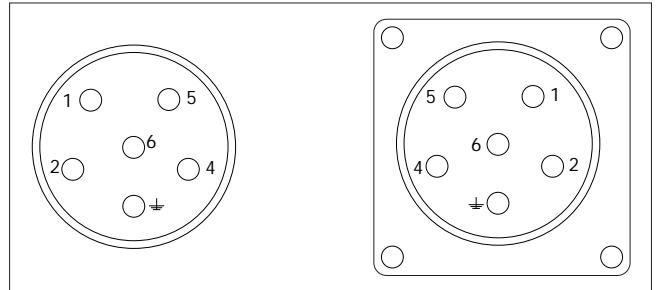

#### MDXKA 100...112

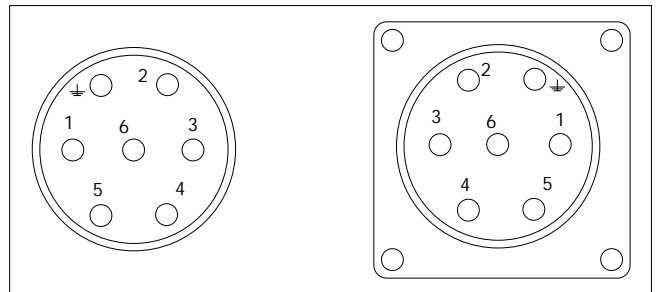

#### Fan connection

	Pin no.	Terminal designation
Earth PE	2	⊕
Fan power L1	A	U1
Fan power N	B	U2
<b>Global Drive system cables</b>		
Standard cable	EWLLxxxGM	
Trailing cable	EWLLxxxGMS	
Intermediate cable	EWLLxxxZM	

#### MDXK

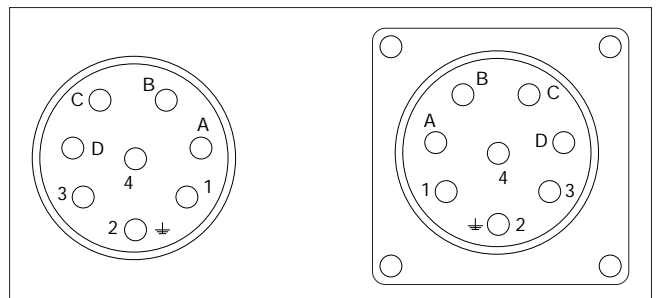

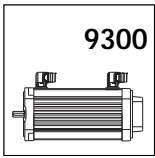

9300

# Technical data

## Motor connection

### Plug-in connectors for motor connection

#### Resolver connection

	Pin no.	Terminal designation
+Ref., transformer / reference winding	1	B1
-Ref., transformer / reference winding	2	B2
+Cos, stator winding	4	B4
-Cos, stator winding	5	B5
+Sin, stator winding	6	B6
-Sin, stator winding	7	B7
Temperature sensor +KTY	11	T1
Temperature sensor -KTY	12	T2
<b>Global Drive system cables</b>		
Standard cable	EWLRxxxGM-T	
Intermediate cable for trailing	EWLRxxxZMST	
Intermediate cable	EWLRxxxZM-T	

#### MDXK, MDFQA

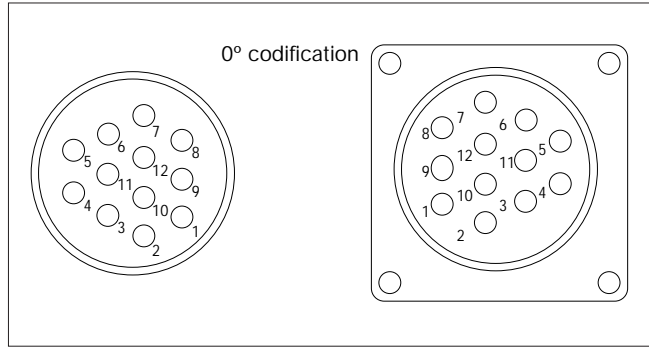

#### Connection of Sin-Cos absolute value and incremental encoder

	Pin no.	Terminal designation
Track +B / +SIN	1	B5
Track -A / -COS	2	B4
Track +A / +COS	3	B3
Supply VCC	4	B1
Mass GND	5	B2
Track -0, -Z / -RS485	6	B8
Track +0, +Z / +RS485	7	B7
Track -B / -SIN	9	B6
Temperature sensor +KTY	11	T1
Temperature sensor -KTY	12	T2
<b>Global Drive system cables</b>		
Standard cable	EWLExxxGM-T	

#### MDXK, MDFQA

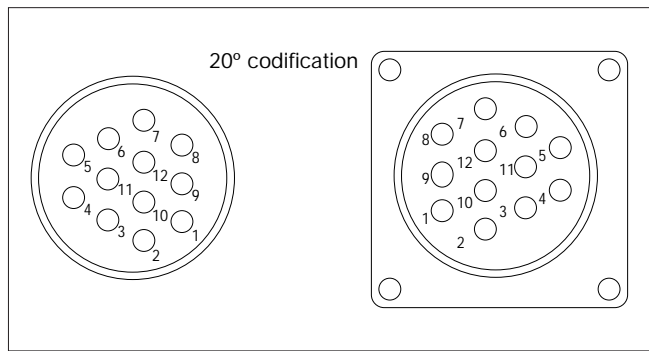

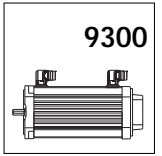

Dimensions of plugs and sockets

Power plug size 036 ... 090

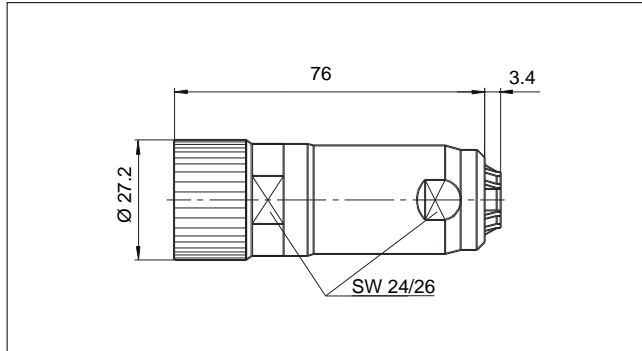

Right angle socket motor size 036 ... 090

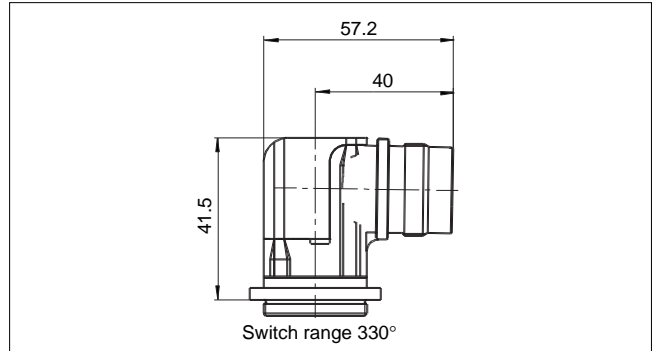

Power plug size 100 ... 112

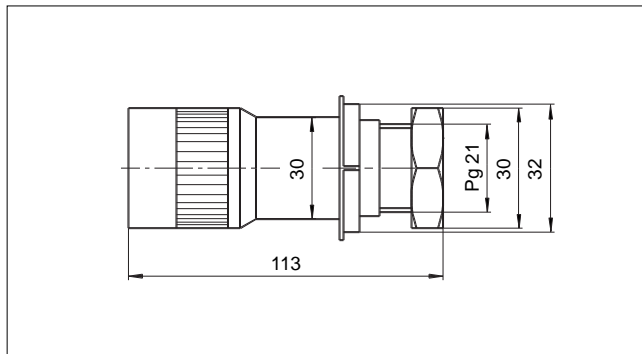

Right angle socket motor size 100 ... 112

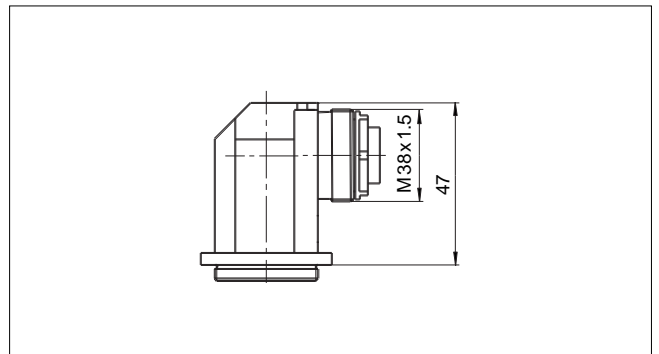

Fan plug

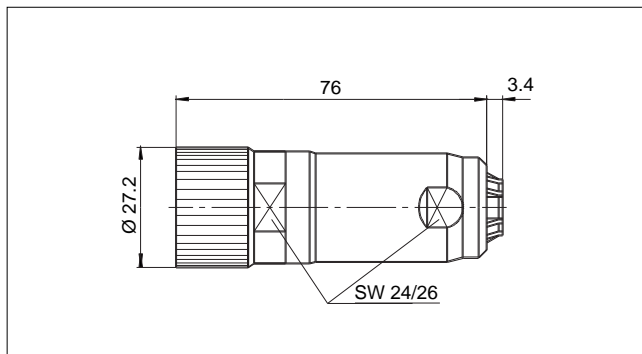

Right-angle socket fan

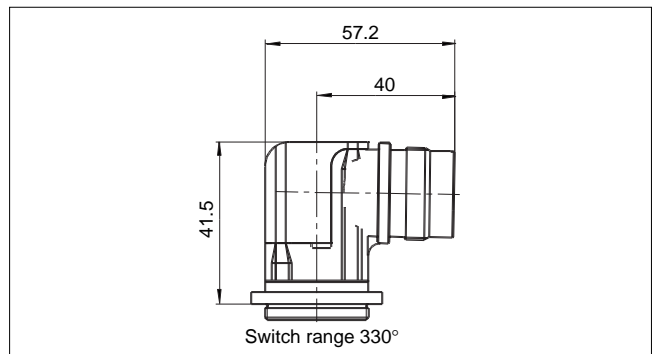

Encoder plug (resolver / Sin-Cos / incremental encoder)

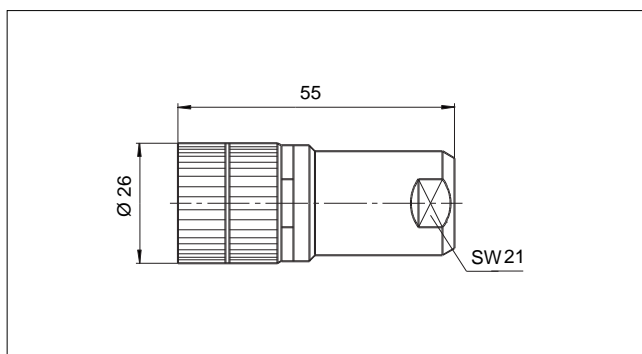

Right-angle socket encoder

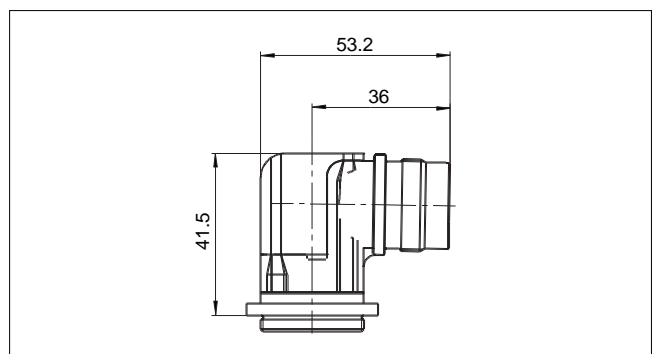

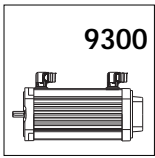

9300

# Technical data

## Motor connection

### Terminal box

As alternative to plug-in connectors, servo motors MDXK can be equipped with terminal boxes for power connection and brake.

The power connection of servo motors MDFQA (enclosed ventilated) is always equipped with a terminal box.

### a) Motor MDXK

#### Connections

	Pin no.	Terminal designation
Brake	5	Y1
Brake	6	Y2
Protective earth	PE	PE
Motor phase	1	U
Motor phase	2	V
Motor phase	3	W

#### Terminals

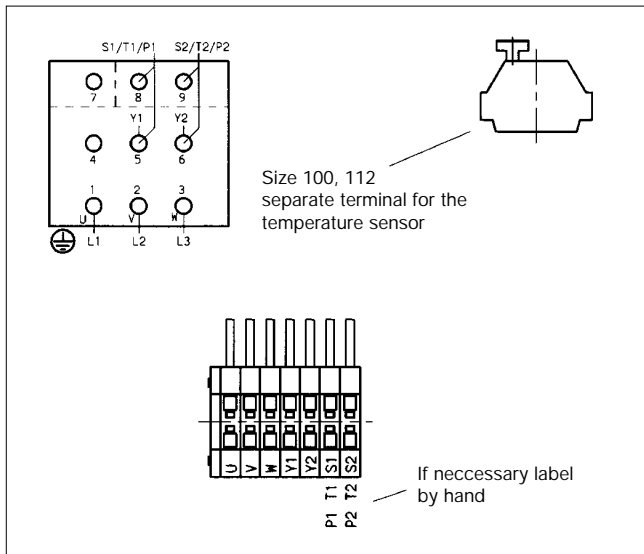

### b) Motor MDFQA

#### Connections

	Terminal designation
Protective earth	PE
Motor phase	U
Motor phase	V
Motor phase	W
Thermostat, connection T1 with 9300	S1
Thermostat, connection T2 with 9300	S2
Temperature sensor*, KTY, con. through encoder	T1
Temperature sensor*, KTY, con. through encoder	T2

\* Motors with feedback have the temperature sensor connected to the encoder plug.

#### Terminals

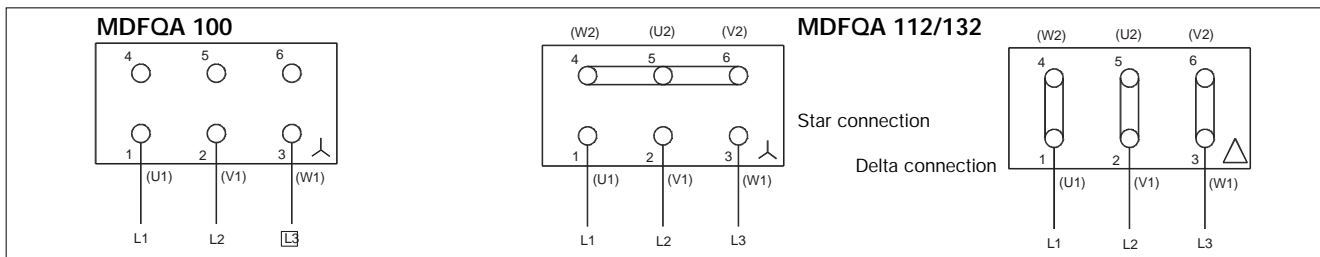
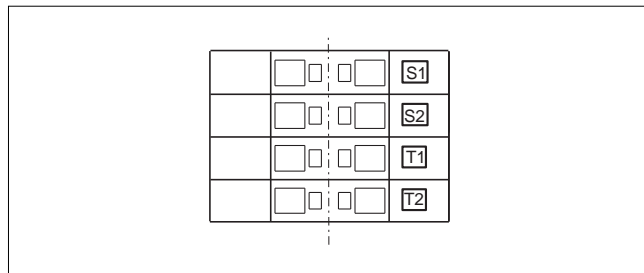

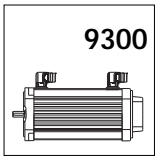

Feedbacks and fans can be connected to a second terminal box.

The feedback of servo motors MDFQA (enclosed ventilated) is always equipped with plug-in connectors.

### Resolver as feedback

#### Connections

	Pin no.	Terminal designation
Temperature sensor	T1	+ KTY
Temperature sensor	T2	- KTY
Resolver	B1	+ Ref
Resolver	B2	- Ref
	B3	
Resolver	B4	+ cos
Resolver	B5	- cos
Resolver	B6	+ sin
Resolver	B7	- sin
	B8	
Separate fan	U1	L1
Separate fan	U2	N

#### Terminals

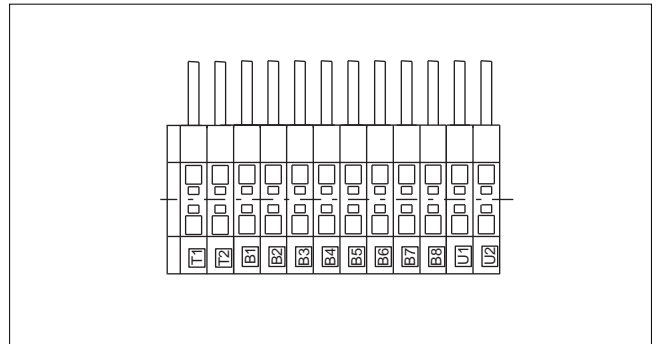

### Incremental encoder of SinCos-encoder as feedback

#### Connections

	Pin no.	Terminal designation
Temperature sensor	T1	+ KTY
Temperature sensor	T2	- KTY
Incremental encoder supply +	B1	+ UB
Incremental encoder supply -	B2	± ov
Incremental encoder track A	B3	A
Incremental encoder track A invers	B4	- A
Incremental encoder track B	B5	B
Incremental encoder track B invers	B6	- B
Inc. encoder track C (zero track)	B7	N
Inc. encoder track C (zero track invers)	B8	N
Incremental encoder mass / sensor	B9	± ov
Incremental encoder screen	B10	Screen
Incremental encoder screen +	B11	+ U sensor
Separate fan	U1	L1
Separate fan	U2	N

#### Terminals

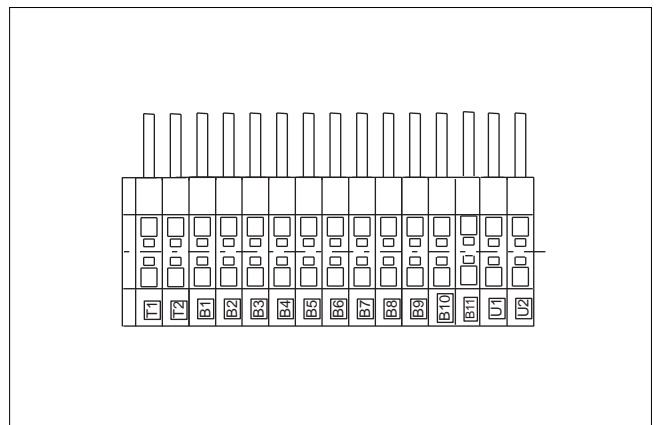

### PG glands and bolts

Motor type	Power connection		Encoder / fan connection
	PG glands	Bolts	PG glands
MDSK 056	1xPG13.5 + 1xPG11	M4 bzw. 0.08...2.5 mm <sup>2</sup>	1xPG13.5 + 1xPG11 + 3xPG7
MDXK 071	1xPG13.5 + 1xPG11	M4 bzw. 0.08...2.5 mm <sup>2</sup>	1xPG13.5 + 1xPG11 + 3xPG7
MDXK 080	1xPG13.5 + 1xPG11	M4 bzw. 0.08...2.5 mm <sup>2</sup>	1xPG13.5 + 1xPG11 + 3xPG7
MDSK 090	1xPG13.5 + 1xPG11	M4 bzw. 0.08...2.5 mm <sup>2</sup>	1xPG13.5 + 1xPG11 + 3xPG7
MDXK 100	2x PG16	M5	2xPG16 + 3x PG7
MDXK 112	1xPG21 + 1xPG16	M5	2xPG16 + 3x PG7
		Power connection	Fan connection
MDFQ 100	2xPG29 + 1xPG9 *	M6	1xPG9
MDFQ 112	2xPG36 + 2xPG9 *	M8	1xPG9
MDFQ 132	4xPG29 + 2xPG9 *	M12	1xPG9

\* For connection of parallel screened cables, e.g. 3 St 4 x 35 mm<sup>2</sup> or 4 St 4 x 25 mm<sup>2</sup>





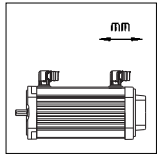

## Synchronous servo motors MDSKS 036, mounting position B5

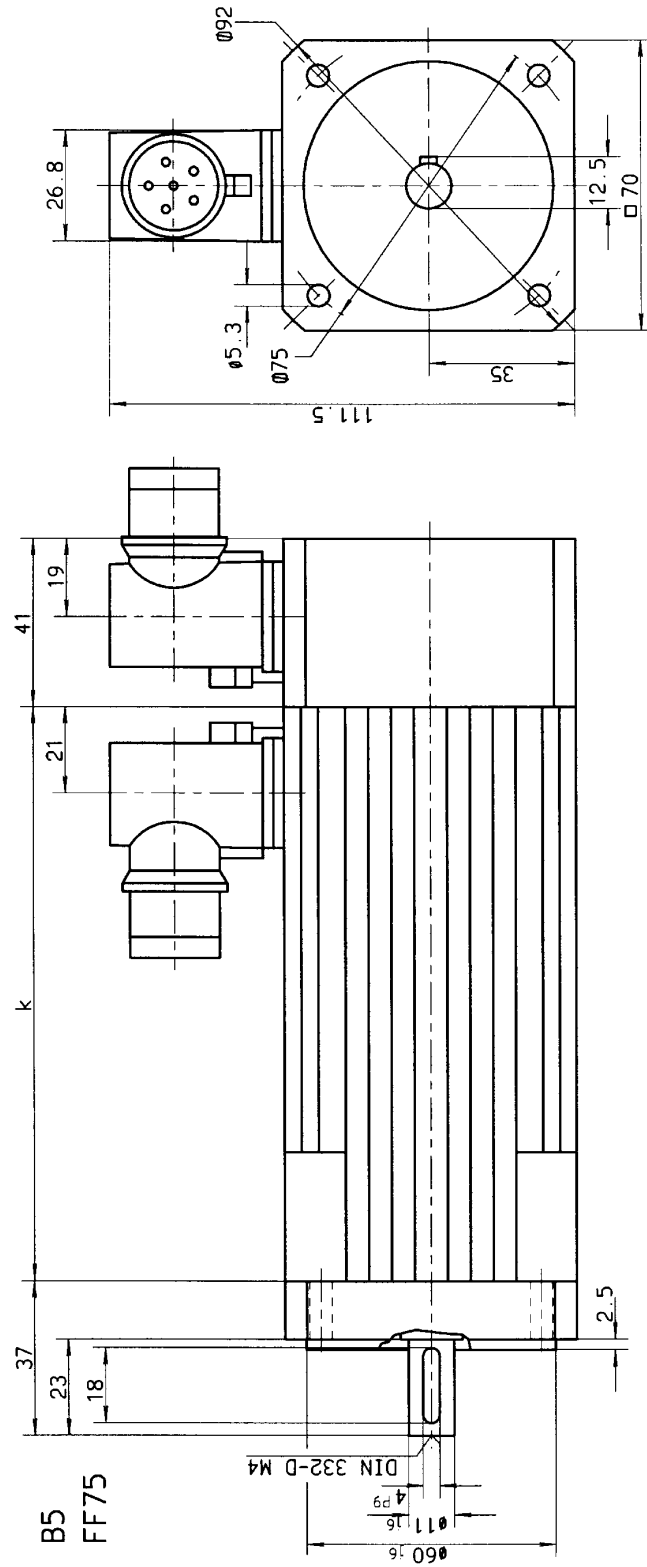

Motor type	without brake	with brake
MDSKSXS036-13	87	115
MDSKSXS036-23	111	139

X-variable  
Rotation of right-angle sockets possible

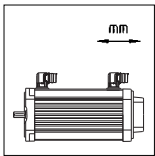

# Dimensions

Synchronous servo motors MDSKS 056, mounting position B5/B14

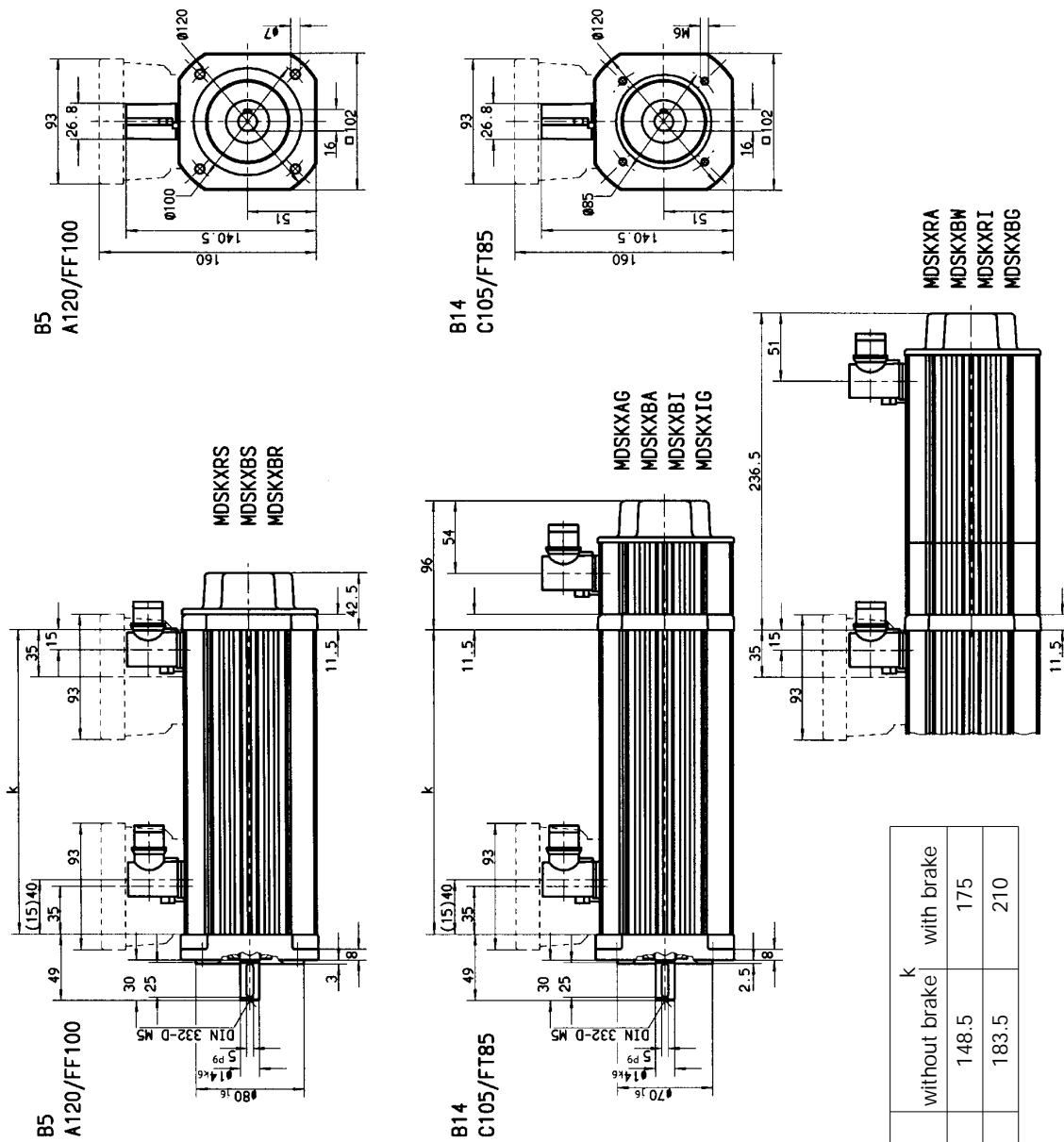

Motor type	without brake	with brake
MDSKSXS056-23, 190	148.5	175
MDSKSXS056-33, 200	183.5	210

( ) - without brake  
 X-variable  
 Rotation of right-angle sockets possible

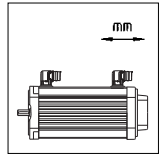

## Synchronous servo motors MDXKS 071, mounting position B5/B14

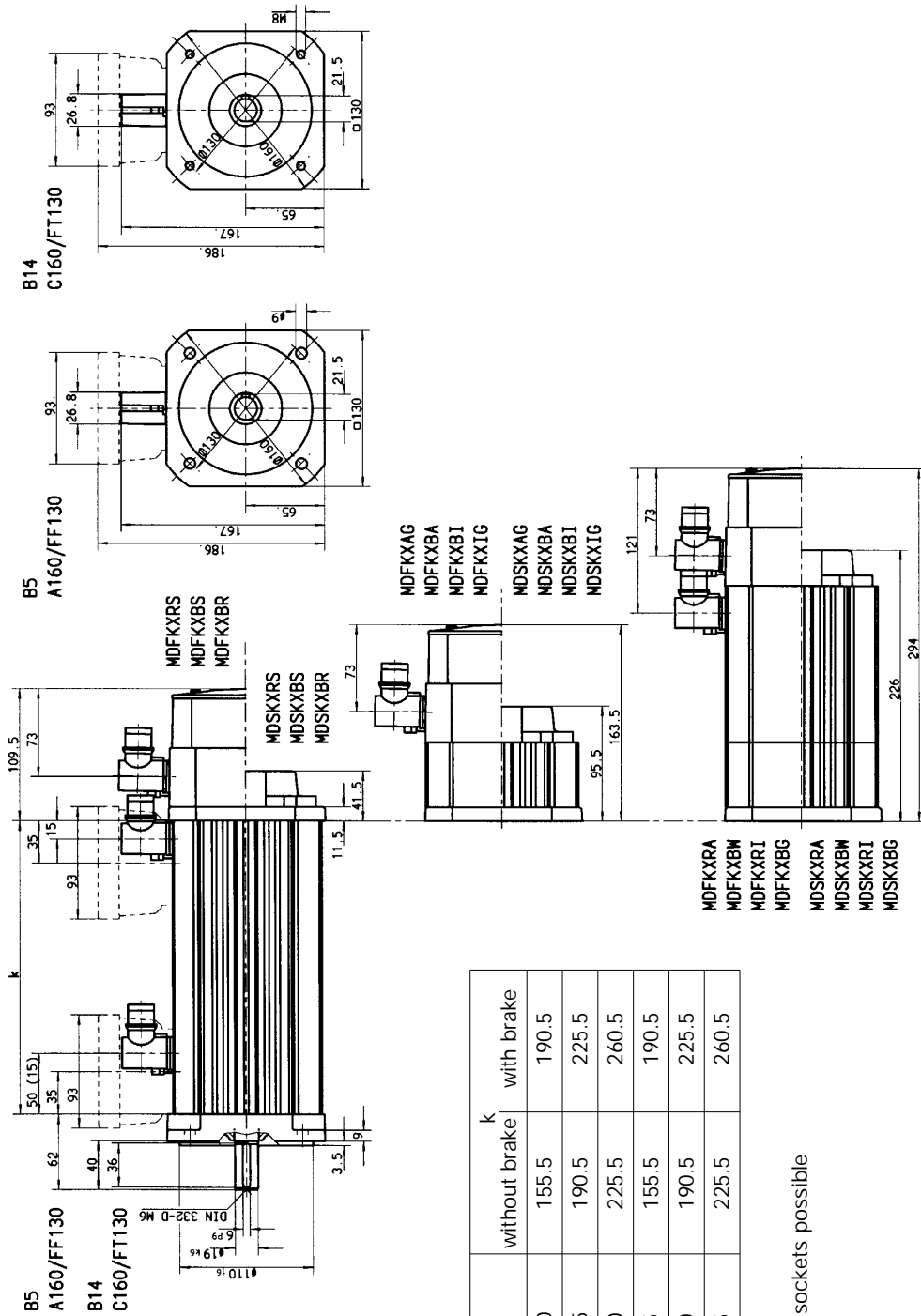

Motor type	k	
	without brake	with brake
MDSKXX071-03, 170	155.5	190.5
MDSKXX071-13, 185	190.5	225.5
MDSKXX071-33, 180	225.5	260.5
MDFKXX071-03, 165	155.5	190.5
MDFKXX071-13, 180	190.5	225.5
MDFKXX071-33, 175	225.5	260.5

( ) - without brake  
 X - variable  
 Rotation of right-angle sockets possible

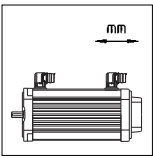

# Dimensions

## Asynchronous servo motors MDSKA 056, mounting position B5/B14

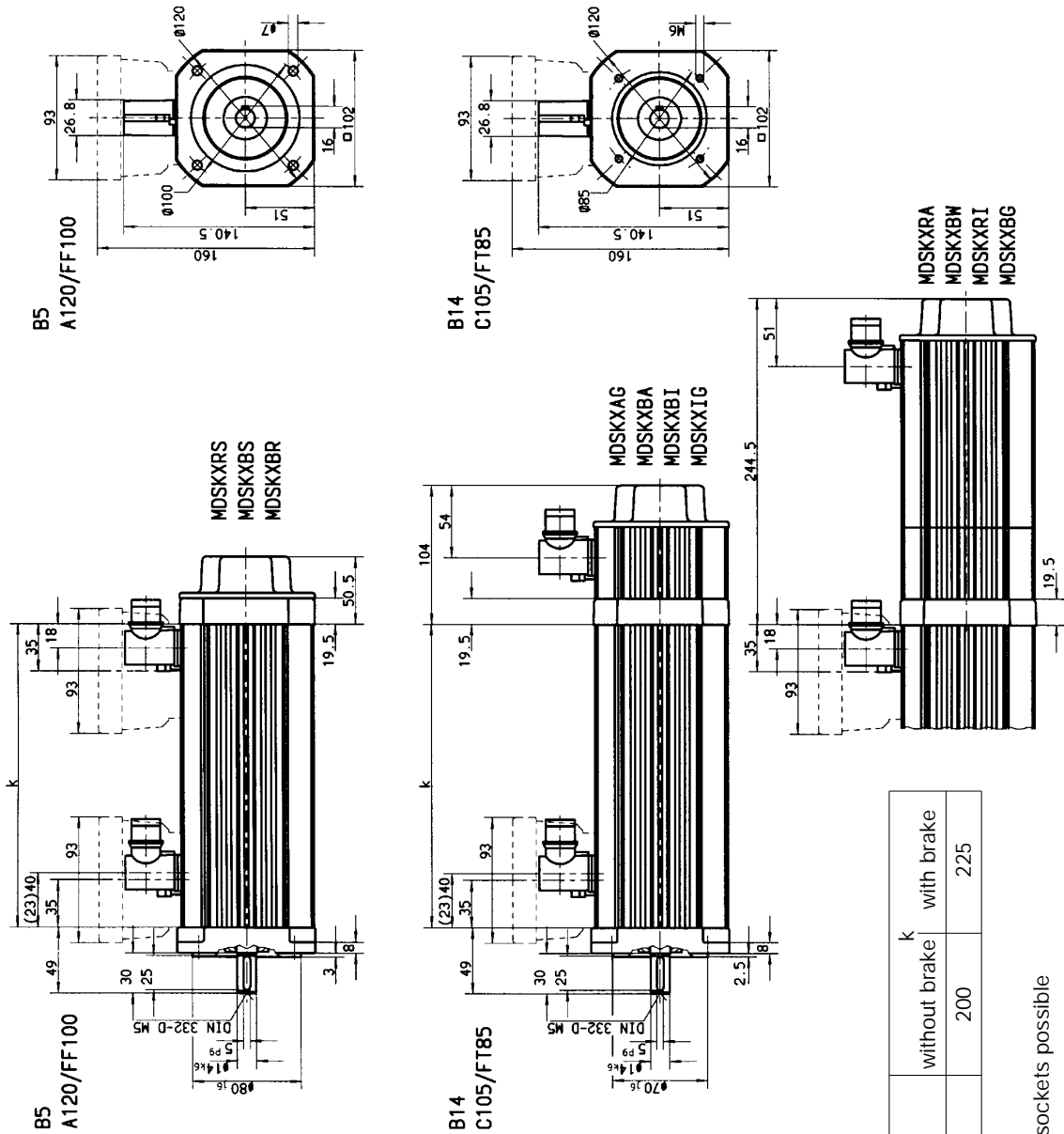

Motor type	k	
	without brake	with brake
MDSKAXX056-22, 140	200	225

( ) - without brake  
 X - variable  
 Rotation of right-angle sockets possible

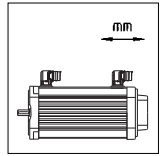

## Asynchronous servo motors MDXKS 071, mounting position B5/B14

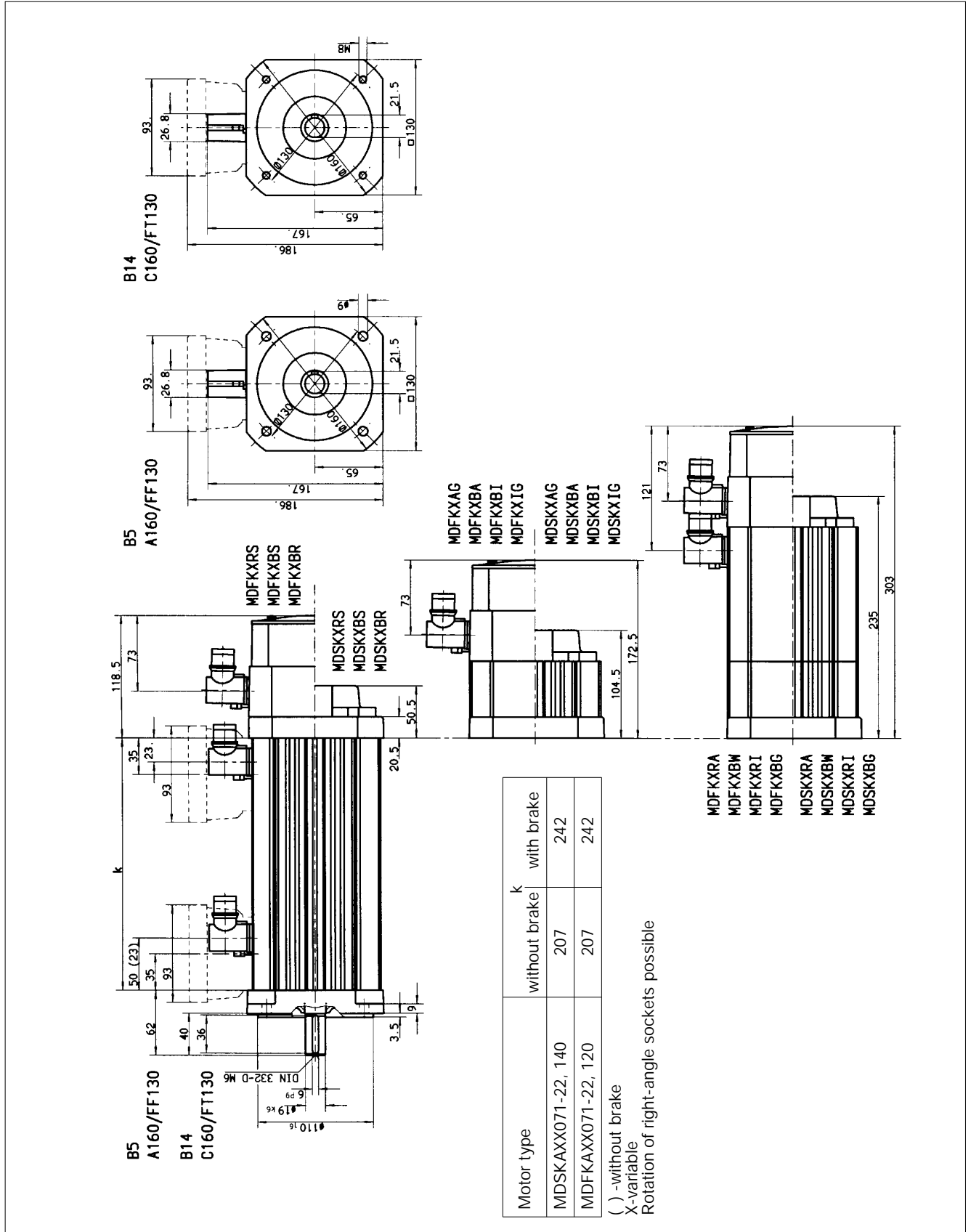

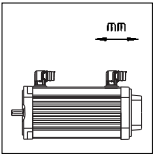

# Dimensions

## Asynchronous servo motors MDXKA 080, mounting position B5/B14

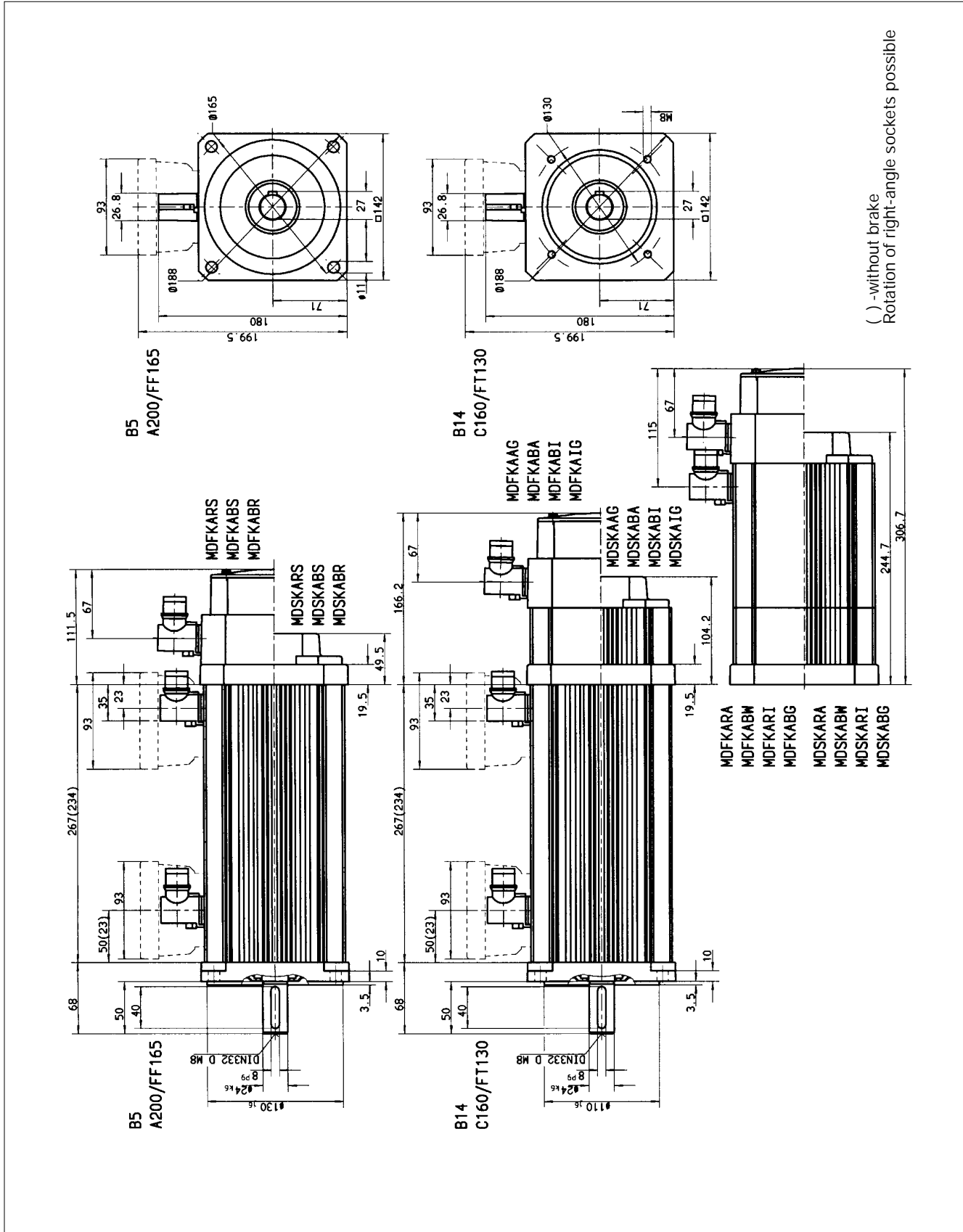





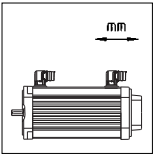

# Dimensions

## Asynchronous servo motors MDXKA 100, mounting position B5/B14

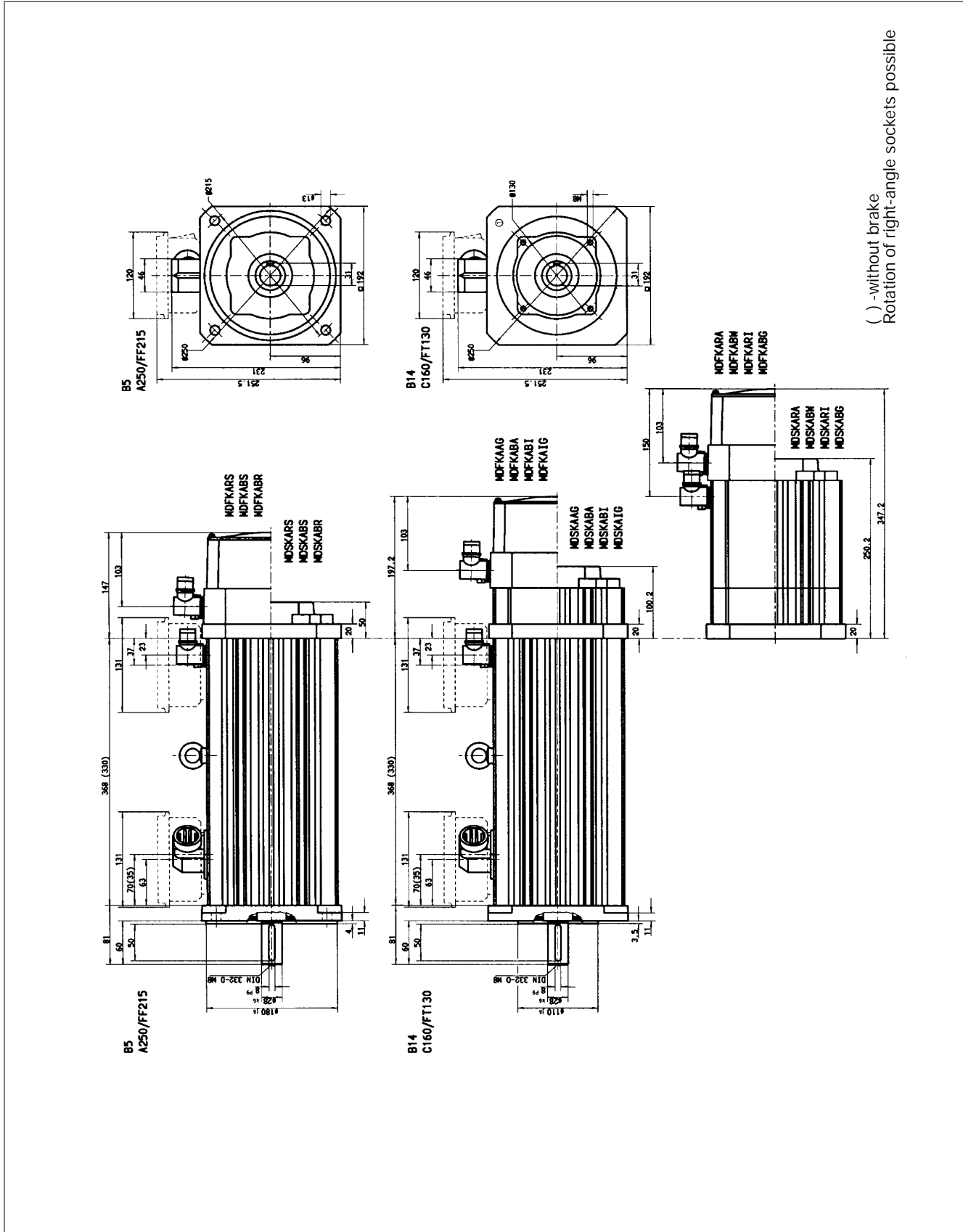

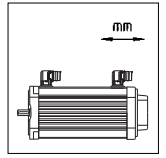

## Asynchronous servo motors MDXKA 112, mounting position B5/B14

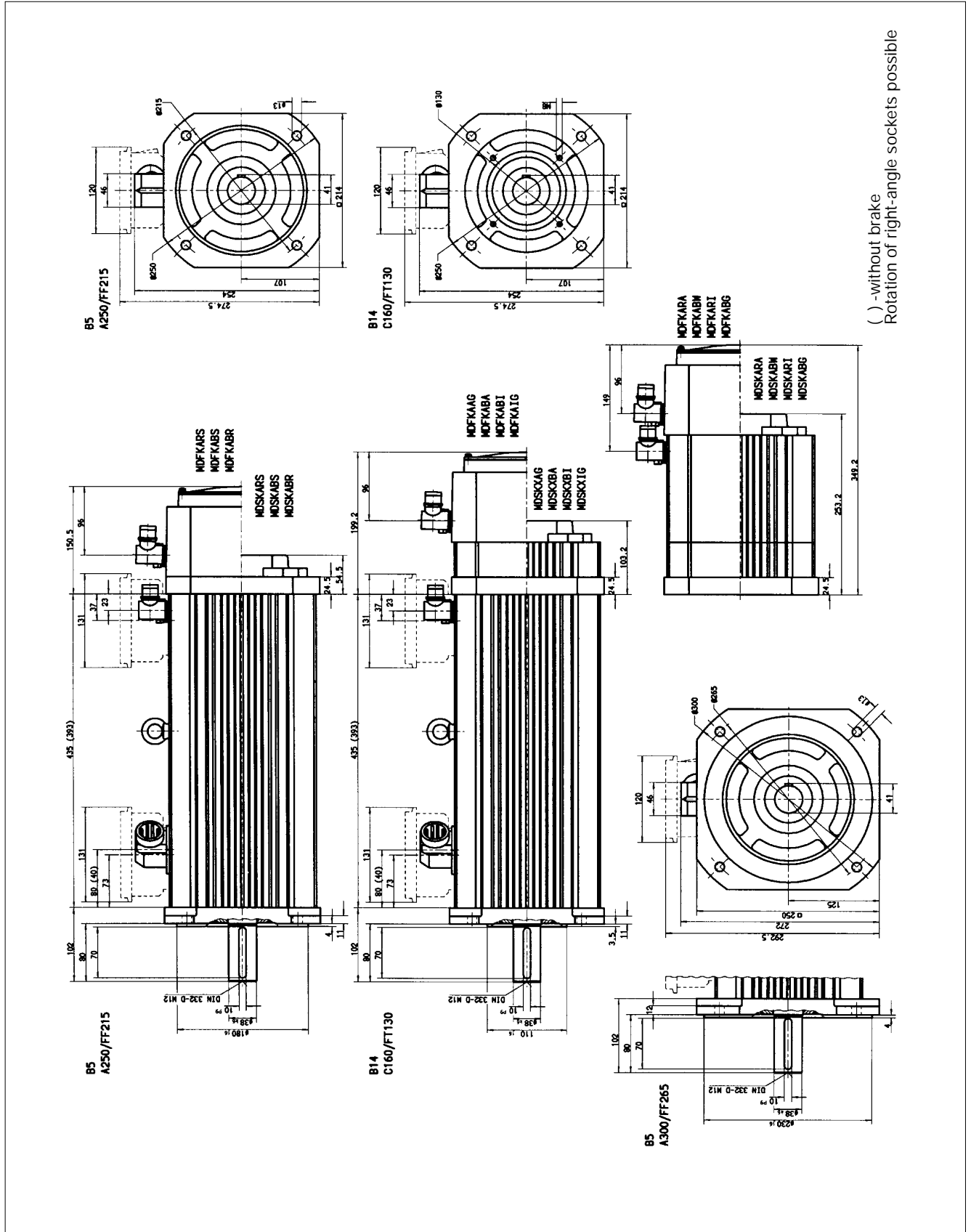

( ) - without brake  
Rotation of right-angle sockets possible

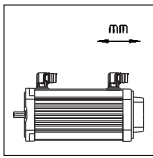

# Dimensions

## Asynchronous servo motors MDFQA 100...132, mounting position B5

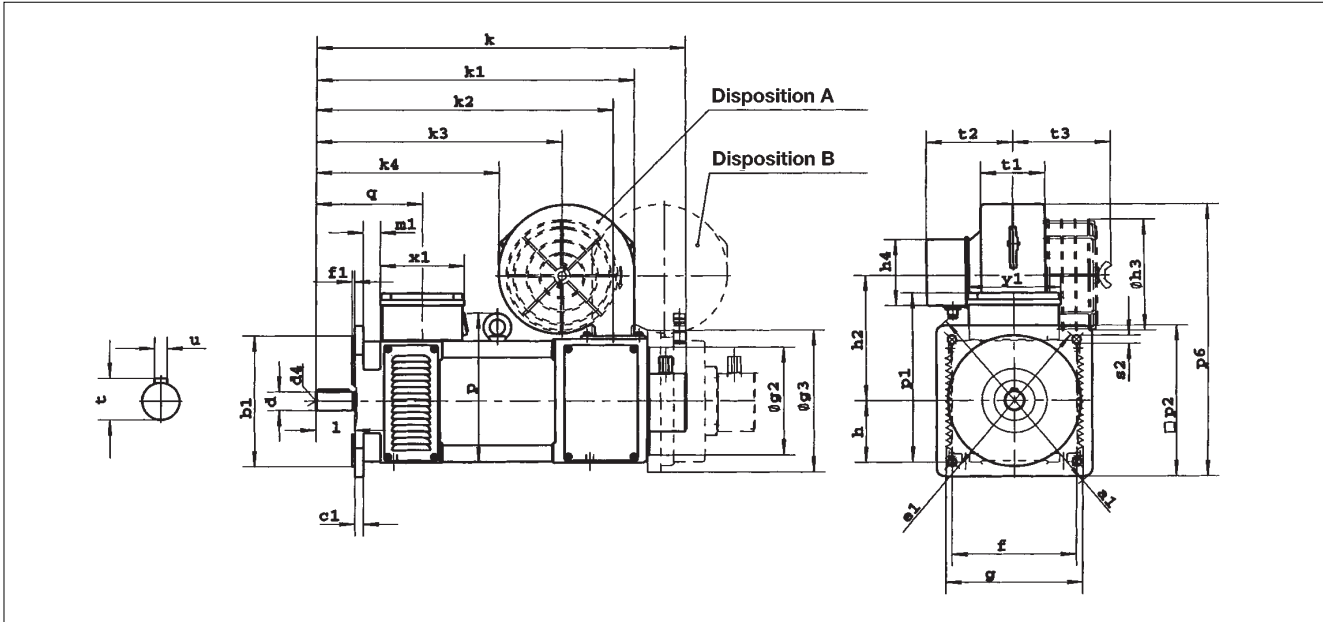

Motor type	Flange to DIN 42948	Flange to IEC 72	a1 P	b1 N	c HA	c1 LA	e1 M	f AB	f1 T	g AC	g2 -	h H	k2 -	m1 -	p -	p1 -	p2 -	q -
MDFQA 100-22	A300	FF265	300	230	14	12	265	196	4	212	163	100	452	25	243	282	220	181
MDFQA 132-32	A400	FF350	400	300	18	20	350	260	5	275	238	132	673	25	315	353	320	257

Motor type	s2 S	x1 -	y1 -	d D	l E	t GA	u F	d4 -	h2 -	h3 -	h4	k1 -	k3 -	k4 -	p6	t1 -	t2 -	t3 -	Separate fan
MDFQA 100-22	14	134	131	38	80	41	10	M12	180	-	94	480	386	304	385	82	111	124	G2D 120
	14	134	131	38	80	41	10	M12	214	185	94	489	348	240	447	100	97	142	G2D 140
	14	134	131	38	80	41	10	M12	204	187	110	487	367	275	421	52	158	64	DNG 3-4.5
MDFQA 132-32	18	261	160	55	110	59	16	M20	250	-	94	730	572	450	553	92	113	-	G2D 180
	18	261	160	55	110	59	16	M20	280	285	140	708	549	413	566	87	255	73	DNG 8-12

### Dimensions k

Motor type	Encoder		
	without	Resolver	ITD 21
MDFQA 100-22	540	572	572
MDFQA 132-32	790	822	822

### Dimensions k

Motor type	Brake 14.450					
	16	18	20	25	Resolver	ITD 21
MDFQA 100-22	666	666	-	-	696	696
MDFQA 132-32	-	-	901	901	933	933
MDFQA 100-132 *	214	243	278	330	-	-

\* = Dimension g3 (outer brake diameter)

Terminal box at top (standard)  
Shaft end fits to DIN 748T3

Key to DIN 6885, p. 1  
Designations to DIN (a, b, c...), IEC (B, A, HA...)

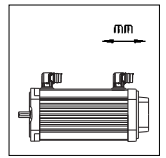

## Asynchronous servo motors MDFQA 100...132, mounting position B35

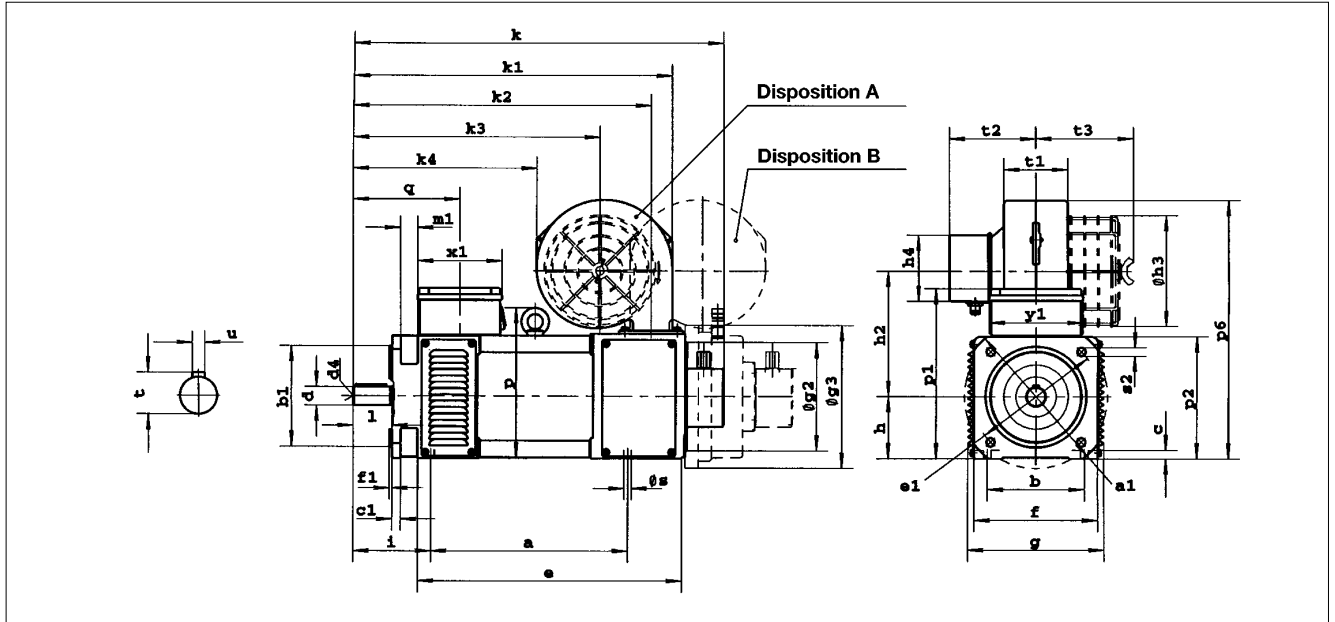

Motor type	Flange to DIN 42948	Flange to IEC 72	a B	a1 P	b A	b1 N	c HA	c1 LA	e BB	e1 M	f AB	f1 T	g AC	g2 -	h H	i -	k2 -	m1 -	p -	p1 -	p2 -
MDFQA 100-22	A250	FF215	295	250	160	180	14	12	382	215	196	4	212	163	100	143	452	25	243	270	198
MDFQA 112-22	A300	FF265	385	300	190	230	16	12	504	265	220	4	235	198	112	150	555	25	267	297	222
MDFQA 132-32	A300	FF265	460	300	215	230	18	12	604	265	260	4	275	238	132	199	673	25	315	353	262

Motor type	q -	s K	s2 S	x1 -	y1 -	d D	l E	t GA	u F	d4 -	h2 -	h3 -	h4 -	k1 -	k3 -	k4 -	p6 -	t1 -	t2 -	t3 -	Separate fan
MDFQA 100-22	181	12	14	134	131	38	80	41	10	M12	180	-	94	-	386	304	375	82	111	-	G2D 120
	181	12	14	134	131	38	80	41	10	M12	214	185	94	489	240	437	100	97	97	142	G2D 140 filter
	181	12	14	134	131	38	80	41	10	M12	204	187	110	487	367	275	411	52	158	64	DNG 3-4.5 wide range
MDFQA 112-22	168	12	14	157	155	38	80	41	10	M12	213	185	94	602	461	354	451	100	97	141	G2D 160
	168	12	14	157	155	38	80	41	10	M12	224	237	q123	590	430	322	466	87	234	96	DNG 5-12.5 Filter and wide range
MDFQA 132-32	257	15	18	261	160	55	110	59	16	M20	250	-	94	730	572	450	525	92	113	-	G2D 180
	257	15	18	261	160	55	110	59	16	M20	280	285	140	708	549	413	558	87	255	73	DNG 8-12 Filter and wide range

### Dimensions k

Motor type	Encoder		
	without	Resolver	ITD 21
MDFQA 100-22	540	572	572
MDFQA 112-22	660	692	692
MDFQA 132-32	790	822	822

Motor type	Brake 14.450					
	16	18	20	25	Resolver	ITD 21
MDFQA 100-22	666	666	-	-	698	698
MDFQA 112-22	-	786	786	-	818	818
MDFQA 132-32	-	-	931	931	963	963
MDFQA 100-132 *	214	243	278	330	-	-

\* = Dimension g3 (outer brake diameter)

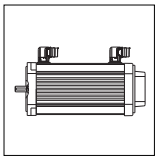

# Selection

## Selection of a servo drive

### Basic data

When installing a servo drive, normally a dynamic operation is required.

The essential data for the appropriate size of the motor are the following:

- Maximum torque  $M_{max}$ , Maximum speed  $n_{max}$ , efficient torque  $M_{eff}$  and if necessary transmission  $i$

- a) **Transmission:** – for **perfect dynamic response**
- b) – for a good use while **continuous operation**

$$i \approx \sqrt{\frac{J_{load}}{J_{motor}}}$$

$$i \approx \frac{n_{rated}}{n_{load}}$$

**Efficient torque:**

$$M_{rms} = \sqrt{\frac{1}{T} \sum_i M_i^2 t_i}$$

**Maximum torque:**

$$M_{max} = M_{accel} + \frac{1}{i} \frac{1}{\eta_{gearbox}} M_{load}$$

$$M_{accel} = 2 \cdot \pi \frac{\Delta n}{\Delta t} (J_{motor} + \frac{1}{i^2} J_{load})$$

### Selection of the motor

After having detected the technical data one may choose between synchronous and asynchronous motors, on the one hand and, on the other hand, between self ventilated

and forced ventilated motors. The main characteristics of the different motor types are listed below:

Select motor according to  $M_{rated} > M_{rms}$  and  $n_{max} > M_{max}$  and take into consideration:

- |  |   |  |
|--|---|--|
| – <b>no stream</b> of air allowed  | → | Motor without fan MDSK   |
| – <b>fluffs</b> or something similar, that might block the air channels            | → | Motor without fan MDSK   |
| – <b>high enclosure</b> required   | → | Motor without fan MDSK   |
| – <b>high dynamic response</b> required  | → | Motor with fan MDFK,<br>Synchr. servo motor MDXKS                        |
| – operation with <b>constant power</b> with high speed (operation with weak field) | → | Asynchr. servo motor MDXKA   |
| – very high <b>power density</b>   | → | Synchr. servo motor MDXKS<br>→ enclosed ventilated asynchr. motors MDFQA |
| – <b>parallel operation</b> of servo mot. with one single inverter                 | → | Asynchr. servo motor MDXKA, MDFQA  |

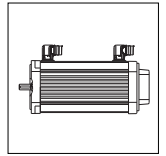

## Selection of a servo drive

### Operational mode: acceleration

Selecting the size of the drives according to the limit characteristics.

- Low noise

→ selection of 16 kHz chopp. fre.

- Check permanent current

→ especially with accelerating drive  
( $I_{\max} > 1.5 I_{\text{rated inverter}}$ )

$$I_{\text{perm}} > I_{\text{medium}} \equiv \frac{1}{T_i} \sum I_{\text{rated motor}} \cdot \frac{M_i}{M_{\text{rated}}} \cdot t_i$$

with synchr. motors

The mean is always below net value.

In the case of the continuous operation S6 and  $M_{\text{efficient}} < M_{\text{rated}}$  the current medium value  $I_{\text{medium}}$  is smaller than the permanent current of the installation.

The following data are important for the operational mode acceleration drive:

Permanent current  $\approx 0.7 \cdot I_{\text{rated inverter}}$

Maximum current  $\approx 2 \cdot I_{\text{rated inverter}}$

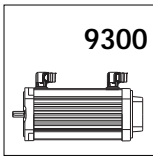

9300

# Selection

## Possible combinations with controllers

Motor-inverter combination servo motor – servo inverter series 9300, 16 kHz chopper frequency

						Possible combinations and standard setting $I_{max} = 1.5 I_n$ , maximum torque in Nm												Possible combinations and operational mode acceleration controller			
						Chopper frequency $f_{chopp}$ $f_{chopp} = 8 \text{ KHz}$												Maximum torque in Nm Chopper frequency $f_{chopp} = 8 \text{ KHz}$			
Inverter type						9321	9322	9323	9324	9325	9326	9327	9328	9329	9330	9331	9332	9321	9322	9323	9324
Continuous current [A]						1.5	2.5	3.9	7.0	13	23.5	32	47	59	89	110	145	1.05	1.7	2.6	4.7
Maximum current [A]						2.3	3.8	5.9	10.5	19.5	35.25	48	70.5	88.5	133.5	165	217.5	3	5	7.8	14
Motor type	h [mm]	$M_{rated}^{3000}$ [Nm]	$I_{rated}$ [A]	$M_{rated}$ [Nm]																	
Synchr. servo motors without fan																					
MDSKS 036-13, 200	35		0.9	0.6	1.5	2.2											1.9				
MDSKS 036-23, 200	35		1.1	1.3	2.7	4.3	5.6										3.5	5.0			
MDSKS 056-23, 190	51	2.9	2.3	2.8	2.8	4.6	7.0										3.7	6.0	9.2		
MDSKS 036-33, 200	51	4.3	3.6	4.2		4.4	6.9	11.7										5.8	9.0	15.2	
MDSKS 071-03, 170	65	5.9	4.2	5.7			8.0	13.8	23.6										10.6	17.8	
MDSKS 071-13, 185	65	8.8	7	8.3			7.0	12.5	22.3	35.2									9.2	16.6	
MDSKS 071-33, 180	65	13	10	12.3				12.9	24.0	41.4										17.2	
with separate fan																					
MDFKS 071-03, 165	65	7.7	5.6	7.5			8.0	13.8	23.5										10.6	17.8	
MDFKS 071-13, 180	65	11.7	9.2	11.0				12.5	21.8	35.2										16.6	
MDFKS 071-33, 175	65	17	13.1	16.2				12.9	24.0	41.4										17.2	



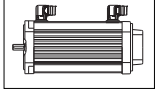

## Possible combinations with controllers

### Motor-inverter combination servo motor – servo inverter series 9300, 8 kHz chopper frequency

								Possible combinations and maximum torque in Nm											
		Inverter type						Chopper frequency $f_{chopp} = 8 \text{ KHz}$											
		Continuous current [A]						9321	9322	9323	9324	9325	9326	9327	9328	9329	9330	9331	9332
		Maximum current [A]						1.5	2.5	3.9	7.0	13	23.5	32	47	59	89	110	145
								2.3	3.8	5.9	10.5	19.5	35.3	48	70.5	88.5	133.5	165	217.5
Motor type	h [mm]	$M_{rated}$ [Nm]	$P_{rated}$ [kW]	$I_{rated}$ [A]	$I_{max}^1$ [A]	$f_{rated}$ [Hz]													
<b>Asynchronous servo motors surface cooled</b>																			
without fan																			
MDSKA 056-22, 140	51	2.0	0.8	2.4		140		4.45	7.3	9.8									
MDSKA 071-22, 140	65	4.0	1.7	4.4		140				12.6	19.5								
MDSKA 080-22, 70	71	6.7	1.4	3.3		70			15.1	29.3									
MDSKA 080-22, 140	71	5.4	2.3	5.8		140				13.2	26.0								
MDSKA 090-22, 80	83	10.8	2.6	5.5		80				24.4	46.2								
MDSKA 090-22, 140	83	9.5	4.1	10.2		140						23.4	43.7	59.4					
MDSKA 100-22, 80	96	16.3	4.0	8.2		80				47.2	88.2								
MDSKA 100-22, 140	96	12.0	5.2	14.0		140				20.7	43.3	60.7							
MDSKA 112-22, 85	107	24.6	6.4	13.5		85				46.2	78.0	92.4							
MDSKA 112-22, 140	107	17.0	7.4	19.8		140						43.9	63.3	96.8	123.0				
with separate fan																			
MDFKA 071-22, 120	65	6.3	2.2	6.0		120				13.0	25.0								
MDFKA 080-22, 60	71	12.0	2.1	4.8		60				29.6	45.2								
MDFKA 080-22, 120	71	10.8	3.9	9.1		120					29.3	53.8							
MDFKA 090-22, 60	83	21.5	3.8	8.5		60					57.2	86.7							
MDFKA 090-22, 120	83	19.0	6.9	15.8		120						50.7	69.2	100.2					
MDFKA 100-22, 60	96	36.3	6.4	13.9		60					50.1	95.9	130.8						
MDFKA 100-22, 120	96	36.0	13.2	28.7		120						45.7	67.6	104.3	132.9	202.0			
MDFKA 112-22, 60	107	61.4	11.0	22.5		60						104.1	143.3	211.0	257.0				
MDFKA 112-22, 120	107	55.0	20.3	42.5		120								107.7	135.9	205.0	250.0		
<b>Asynchronous servo motors. enclosed ventilated</b>																			
MDFQA 100-22, 50	100	$\lambda$	71.3	10.6	26.5		50					109.3	156.7	232.0	253.0				
MDFQA 100-22, 100	100	$\lambda$	66.2	20.3	46.9		100							112.5	146.4	227.0	257.0		
MDFQA 112-22, 50	112	$\lambda$	145	11.5	27.2		28						247.0	339.0	346.0				
MDFQA 112-22, 50	112	$\Delta$	135	20.1	43.7		50							230.1	292.9	341.8			
MDFQA 112-22, 100	112	$\lambda$	130	22.7	49.1		58							180.5	228.0	342.0	378.0		
MDFQA 112-22, 100	112	$\Delta$	125	38.4	81.9		100									216.0	273.0	355.0	
MDFQA 132-32, 36	132	$\lambda$	296	17.0	45.2		20							482.0	612.0	751.0			
MDFQA 132-32, 36	132	$\Delta$	288	31.1	77.4		36									552.0	671.0		
MDFQA 132-32, 76	132	$\lambda$	282	35.4	88.8		42									424.0	512.0	663.0	
MDFQA 132-32, 76	132	$\Delta$	257	60.1	144.8		76										344.0	458.0	

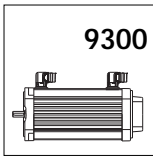

9300

# Selection

## Possible combinations with controllers

Motor-inverter combination servo motor – servo inverter series 9300, 16 kHz chopper frequency (low noise)

				Possible combinations and standard setting $I_{max} = 1.5 I_n$ Maximum torque in Nm								Possible combinations and controller for the operational mode acceleration Maximum torque in Nm Chopper frequency $f_{chopp} = 16 \text{ KHz}$			
				Chopper frequency $f_{chopp} = 16 \text{ KHz}$											
Inverter type				9321	9322	9323	9324	9325	9326	9327	9321	9322	9323	9324	
Continuous current [A]				1.1	1.8	2.9	5.2	9.7	15.3	20.8	0.77	1.26	2.03	3.64	
Maximum current [A]				2.7	2.7	4.4	7.8	14.6	23	31.2	2.2	3.6	5.8	10.4	
Motor type	h [mm]	$I_{rated}$ [A]	$M_{rated}$ [Nm]												
Synchronous servo motors without fan															
MDSKS 036-13, 200	35	0.9	0.6	1.1	1.7	2.4					1.4	2.1			
MDSKS 036-23, 200	35	1.1	1.3	2.0	3.2	4.7					2.6	4.0	5.5		
MDSKS 056-23, 190	51	2.3	2.8	2.1	3.3	5.4	9.2				2.7	4.4	6.9		
MDSKS 036-33, 200	51	3.6	4.2			5.1	9.0	15.8					6.8	11.6	
MDSKS 071-03, 170	65	4.2	5.7			6.0	10.6	18.5					7.9	13.7	
MDSKS 071-13, 185	65	7	8.3				9.2	17.2	25.9	34.4				12.3	
MDSKS 071-33, 180	65	10	12.3					18.0	27.9	36.9					
with separate fan															
MDFKS 071-03, 165	65	5.6	7.5				10.6	18.5						13.7	
MDFKS 071-13, 180	65	9.2	11.0				9.2	17.2	25.9	34.4				12.3	
MDFKS 071-33, 175	65	13.1	16.2					18.0	27.9	36.9					

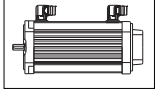

## Possible combinations with controllers

Motor-inverter combination servo motor – servo inverter series 9300, 16 kHz chopper frequency (low noise)

				Possible combinations and maximum torque in Nm												
				Chopper frequency $f_{chopp} = 16 \text{ KHz}$												
		Inverter type		9321	9322	9323	9324	9325	9326	9327	9328	9329	9330	9331	9332	
		Continuous current [A]		1.1	1.8	2.9	5.2	9.7	15.3	20.8	30.6	38	58	70	90	
		Maximum current [A]		1.7	2.7	4.4	7.8	14.6	23	31.2	45.9	57	87	105	135	
Motor type	h [mm]	$M_{rated}$ [Nm]	$P_{rated}$ [kW]	$I_{rated}$ [A]	$f_{rated}$ [Hz]											
<b>Asynchronous servo motors, surface cooled without fan</b>																
MDSKA 056-22, 140	51	2.0	0.8	2.4	140			5.3	9.2							
MDSKA 071-22, 140	65	4.0	1.7	4.4	140				9.2	17.3						
MDSKA 080-22, 70	71	6.7	1.4	3.3	70				21.2	35.1						
MDSKA 080-22, 140	71	5.4	2.3	5.8	140				9.1	19.1	30.8					
MDSKA 090-22, 80	83	10.8	2.6	5.5	80				17.5	34.5	50.0					
MDSKA 090-22, 140	83	9.5	4.1	10.2	140					16.9	28.0	38.6	56.9			
MDSKA 100-22, 80	96	16.3	4.0	8.2	80					33.8	56.7	78.1				
MDSKA 100-22, 140	96	12.0	5.2	14.0	140					25.8	37.6	57.9				
MDSKA 112-22, 85	107	24.6	6.4	13.5	85					55.8	71.4	90.3	97.5			
MDSKA 112-22, 140	107	17.0	7.4	19.8	140						37.5	60.1	76.8	120.8		
<b>with separate fan</b>																
MDFKA 071-22, 120	65	6.3	2.2	6.0	120					19.0	26.3					
MDFKA 080-22, 60	71	12.0	2.1	4.8	60				21.5	41.3						
MDFKA 080-22, 120	71	10.8	3.9	9.1	120					21.2	34.9	47.7				
MDFKA 090-22, 60	83	21.5	3.8	8.5	60					42.0	67.9	86.2				
MDFKA 090-22, 120	83	19.0	6.9	15.8	120						44.6	66.1	81.7			
MDFKA 100-22, 60	96	36.3	6.4	13.9	60						60.5	84.3	125.2	150.7		
MDFKA 100-22, 120	96	36.0	13.2	28.7	120							64.0	75.4	130.5	158.3	
MDFKA 112-22, 60	107	61.4	11.0	22.5	60						91.2	136.9	170.4	254.0		
MDFKA 112-22, 120	107	55.0	20.3	42.5	120								133.6	161.1	206.0	
<b>Asynchronous servo motors, enclosed ventilated</b>																
MDFQA 100-22, 50	100	$\lambda$	71.3	10.6	26.5	50						149.0	189.2	250.0		
MDFQA 100-22, 100	100	$\lambda$	66.2	20.3	46.9	100								143.6	175.2	227.2
MDFQA 112-22, 50	112	$\lambda$	145	11.5	27.2	28						236.0	292.0	346.0		
MDFQA 112-22, 50	112	$\Delta$	135	20.1	43.7	50								288.5	314.3	
MDFQA 112-22, 100	112	$\lambda$	130	22.7	49.1	58								224.0	269.0	343.0
MDFQA 112-22, 100	112	$\Delta$	125	38.4	81.9	100									159.4	217.0
MDFQA 132-32, 36	132	$\lambda$	296	17.0	45.2	20								605.0	681.0	753.0
MDFQA 132-32, 36	132	$\Delta$	288	31.1	77.4	36									440.0	556.0
MDFQA 132-32, 76	132	$\lambda$	282	35.4	88.8	42										428.0
MDFQA 132-32, 76	132	$\Delta$	257	60.1	144.8	76										

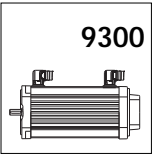

9300

# Application examples

## Connection diagram

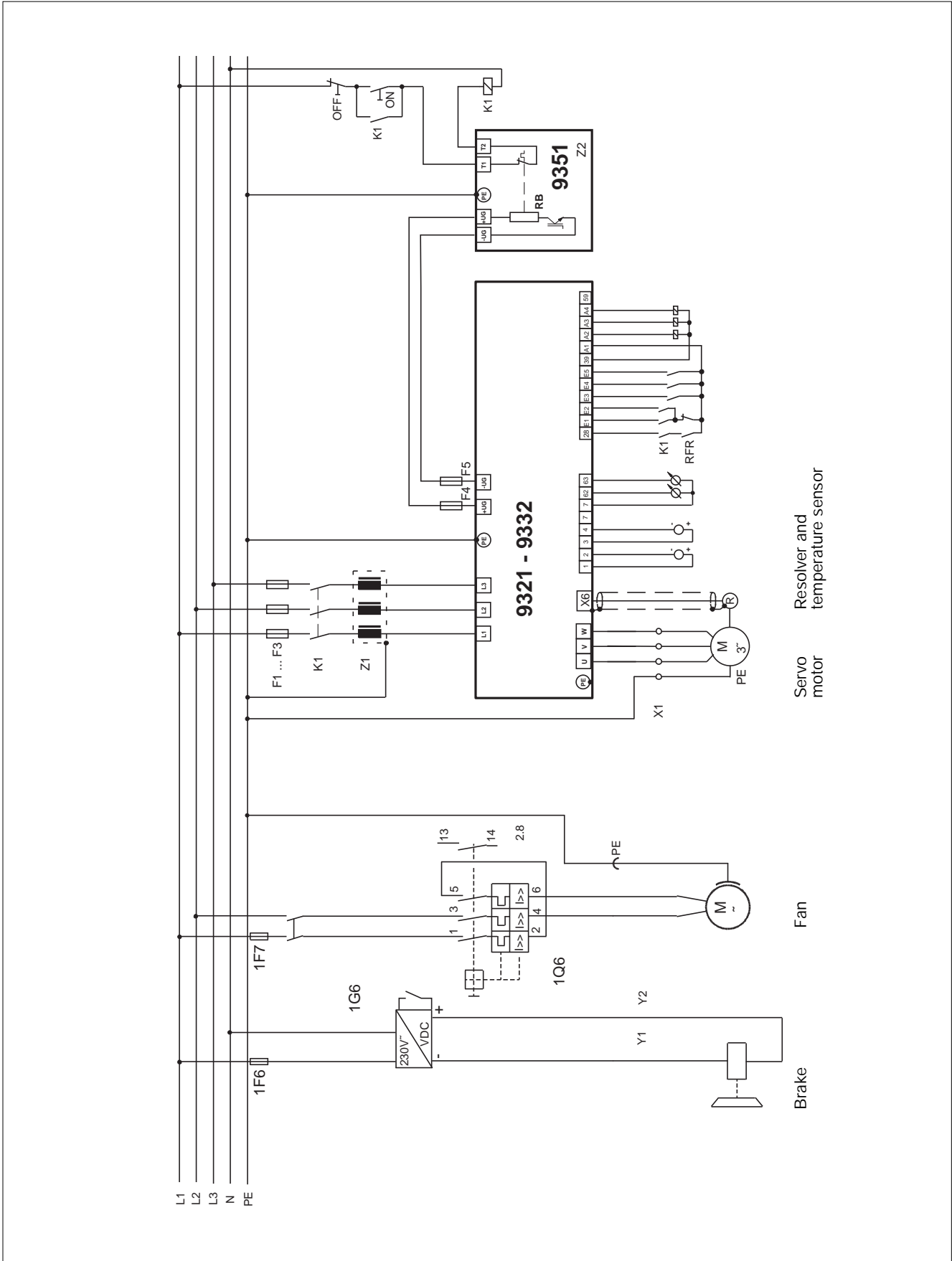

Servo motor  
Resolver and temperature sensor

Fan

Brake

## EC-Declaration – Low-voltage Directive (73/23/EEC)

### EC-Declaration of Conformity '96

for the purpose of the  
EC Low-Voltage Directive (73/23/EEC)

amended by: CE- mark directive (93/68/EEC)

The following products were developed, designed, and manufactured in compliance with the above-mentioned EC directive under the sole responsibility of  
**Lenze GmbH & Co KG, Postfach 10 13 52, D-31763 Hameln**

## Lenze

Electronic drives

Lenze GmbH & Co KG  
Postfach 10 13 52  
D-31763 Hameln

Site: Groß Berkel  
Hans-Lenze-Straße 1  
D-31855 Aerzen  
Telephone (05154) 82-0  
Telefax (05154) 82-26 11

**Product:**

DC motors

Asynchronous motors

Servo motors

Three-phase AC winder motors

**Type:**

MGFRK, MGFOU, MGFOK  
MGERK, MGEQU, MGEOK  
MGSRK, MGSQU, MGSOK  
13.12<sub>o</sub> , 13.53<sub>o</sub> , 13.55<sub>o</sub>  
43.55<sub>o</sub>

13.71<sub>o</sub> , 13.74<sub>o</sub> , 13.75<sub>o</sub>  
13.81<sub>o</sub> , 13.84<sub>o</sub> , 13.85<sub>o</sub>  
DFRA, DERA, DSRA  
43.71<sub>o</sub> , 43.75<sub>o</sub>

DFVA, DSVa, MDFQA  
MDFKA, MDSKA  
MDFKS, MDSKS

o oL12, o oF12  
o oS8, o oS6  
o oS4, o oF4  
o oMF4, o oSF4  
o oLF4

**Standards:**

EN 60204-1, IEC 204-1  
EN 60034, VDE 0530, IEC34

**Declaration about EMC directive (89/336/EEC)**

Asynchronous motors comply with the requirements of the EC directive „Electromagnetic Compatibility“ 89/336/EEC under consideration of the standards EN 80081-1 and EN 50082-2 when connected to a sinusoidal AC mains voltage.

For inverter or DC-controller operation, the EMC notes of the manufacturers must be observed.  
When using screened motor cables, the screening is most effective with a conductive connection with as large an area as possible between the screen and the earth potential of the motor (e.g. metal cable gland).

Hameln, February 20, 1996



(i. V. Pankow)  
Head of R & D Department