

Spring-applied brake

INTORQ BFK461

4 – 235 Nm



INTORQ

setting the standard

www.intorq.de



BFK46 1, sealed design

The INTORQ range of spring-applied brakes is being expanded with the addition of the new BFK461 series of sealed designs. This brake has been specifically developed for application areas with high enclosure requirements. It is a self-contained system available in seven sizes and with braking torques of 4 - 235 Nm is ideal for use in wind power plants, cranes and textile machines.

Features

- Spring-applied brake, sealed design, IP65 enclosure
- Designs with and without flange
- Long maintenance intervals

Example applications

- Brake motors
- Wind power plants
- Car wash systems
- Cranes
- Hoists
- Textile machines



Contents

Product key	4
Product information	5
Principle of operation	6
Technical data	
Dimensions	7
Rated data	8
Braking torques	8
Operating times	9
Explanations	9
Service life and wear	10
Available variants	11
Sales and service around the world	12



Product key INTORQ BFK461-□□□

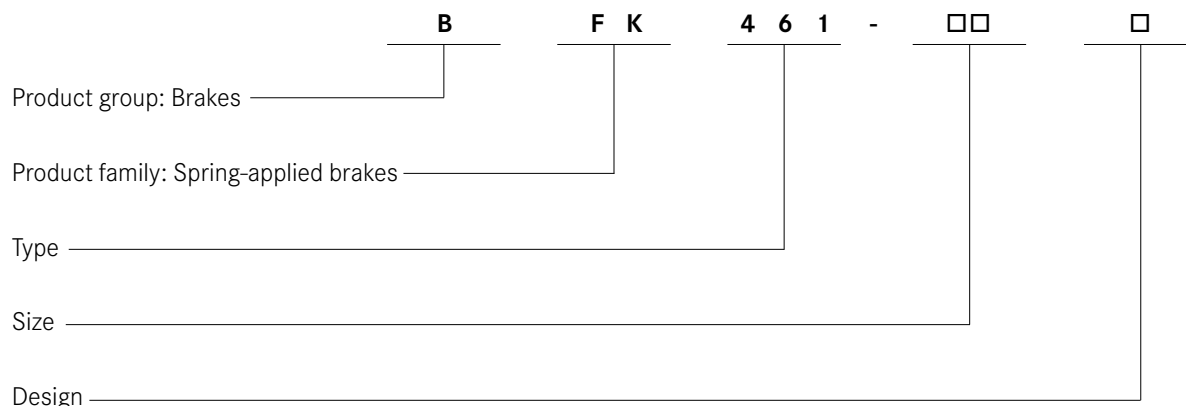

Sizes

06, 08, 10, 12, 14, 16, 18

Not coded:

Supply voltage, hub bore, options

Stator design

N - Non-adjustable in the sealed design

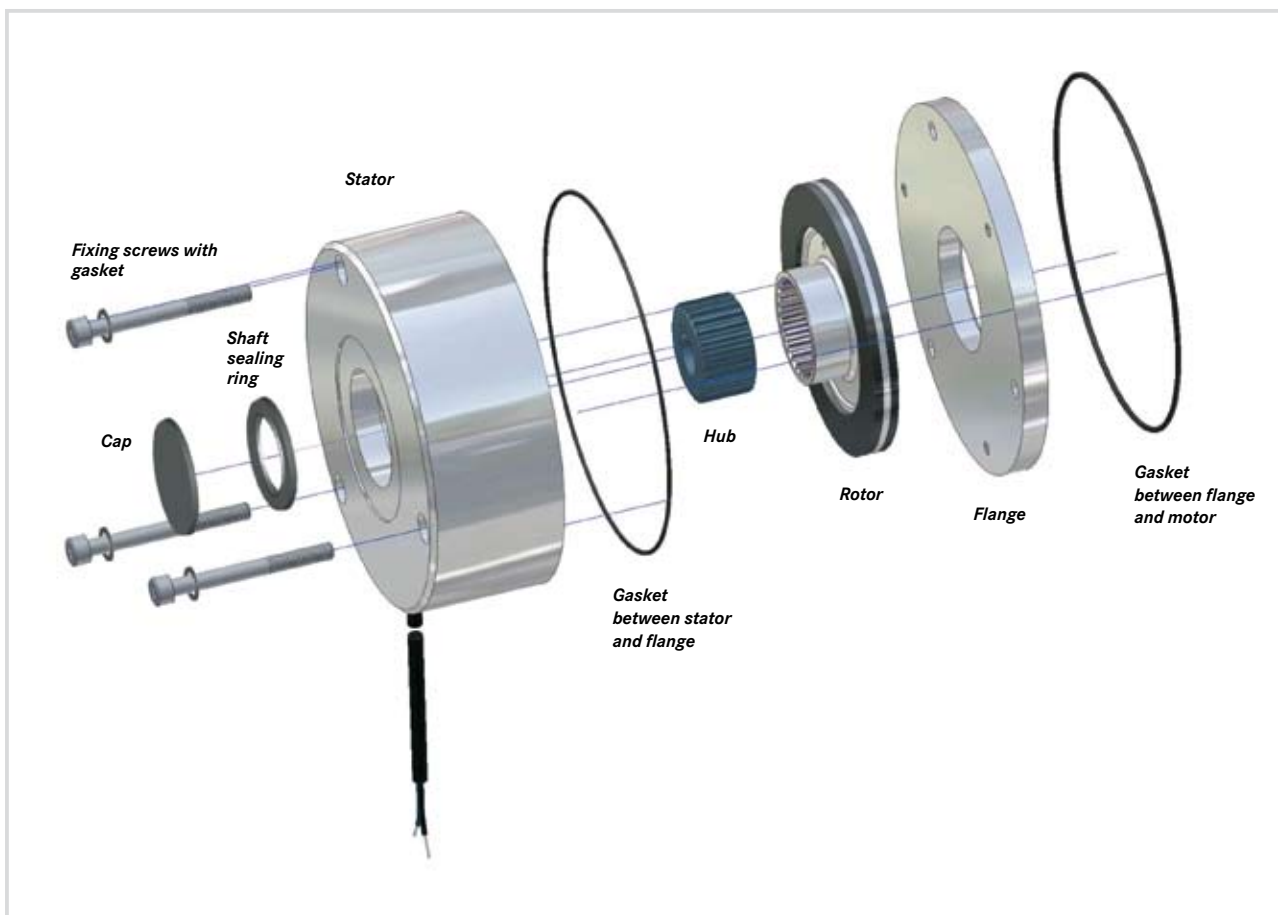

Product information

INTORQ BFK461 spring-applied brake

A powerful and complete range

- 7 sizes
- Standard voltages 24V, 103 V, 180-V, 205 V
- Torque range 4---235 Nm

Versatile

- Modular structure for virtually all applications
- Dimensions identical to the BFK458 range

Torque transmission

- Designed for dry running

Ready for operation immediately

- Preset air gap, quick and easy mounting
- Special machining of the friction surfaces ensures that the characteristic torques are achieved after very few switching operations.
- No fixed bearing is required on the brake

Durable

- The insulation system to temperature class F (155°C) ensures that the winding has a long service life
- These brakes are designed for 100% operating time (current applied to the brake)

Low maintenance

- Long rotor/hub connection with low rate of wear and a tried-and-tested involute gear
- Asbestos-free friction linings with low rate of wear

Reliable

- The certified ISO-9001 and ISO 14001 quality system provides the basis for consistently high-quality products
- Manufacture and testing to VDE 0580



Principle of operation

BFK461 spring-applied brake

Brake module rotor + hub + flange

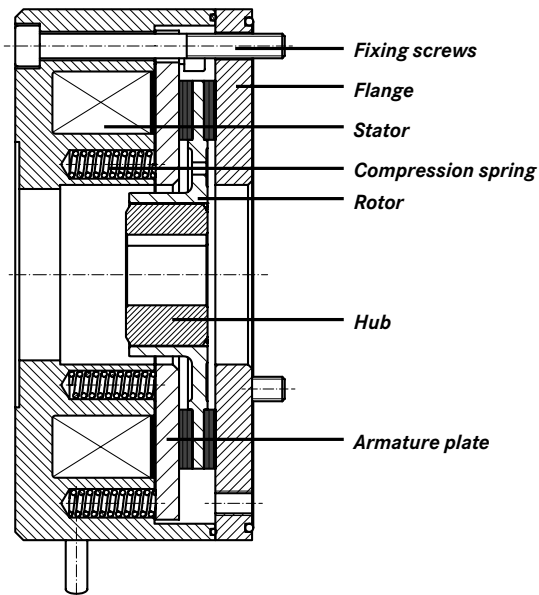

INTORQ BFK461 spring-applied brakes are single-disc brakes with two friction surfaces. When de-energised, several compression springs are used to generate the braking torque through friction locking. The brake is released electromagnetically. During braking, the compression springs use the armature plate to press the rotor (which can be shifted axially on the hub) against the counter friction face.

When the brakes are applied, an air gap s_{air} is present between the armature plate and the stator.

The stator's coil is energised with DC voltage in order to release the brake.

The resulting magnetic force works against the spring force to pull the armature plate towards the stator. This relieves the spring force on the rotor which can then rotate freely.

General information

INTORQ brakes are designed so that the stated rated torques are reliably attained after a short run-in operation.

Given the fluctuating properties of the organic friction linings used and changing environmental conditions, there may however be deviations from the stated braking torques. Appropriate safety factors in the design must take this into account.

An increased breakaway torque may in particular be experienced in damp conditions and with changing temperatures after long downtimes.

The braking torque should be checked when using the brake on the customer's friction surfaces. If the brake is being used solely as a holding brake without any dynamic load, the friction lining must be reactivated regularly.

Technical data

BFK461, sealed design with rotor and flange

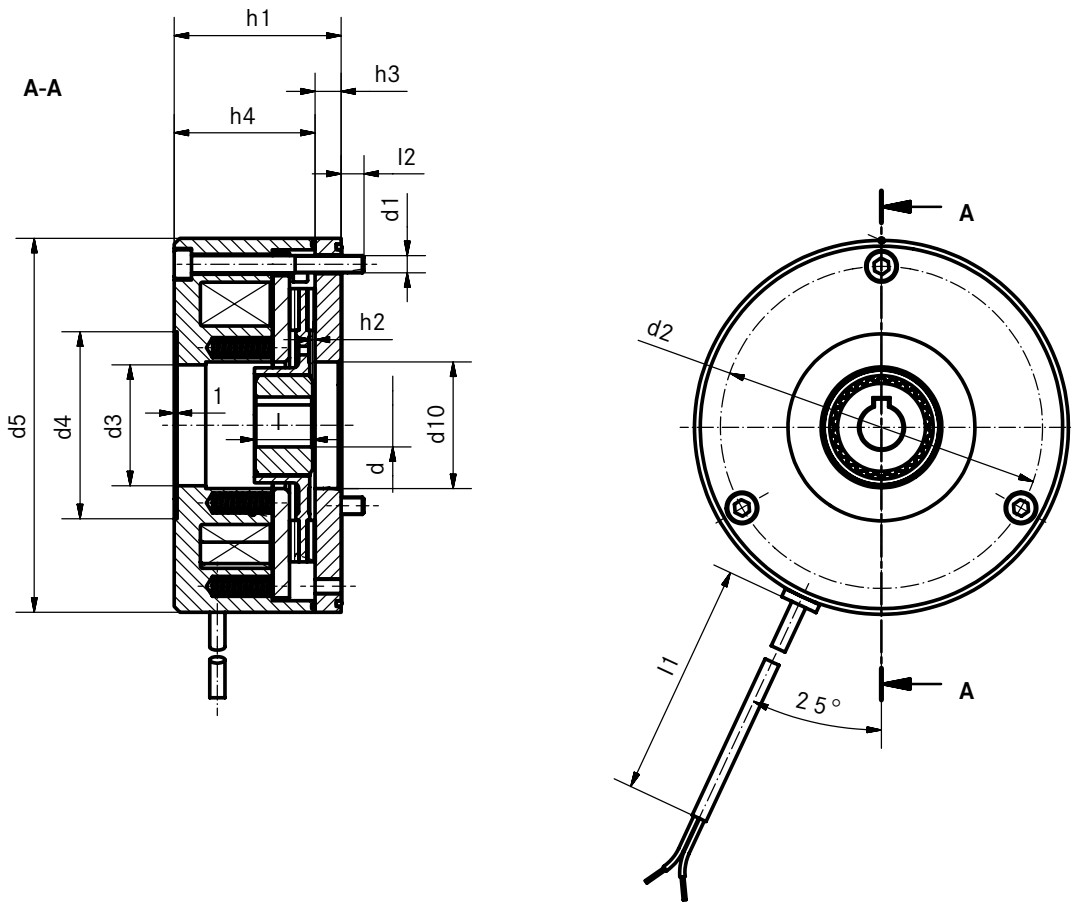

Size	M _k default	M _k max.	P ₂₀	dH7 max.	d ₁	d ₂	d ₃ H7	d ₄	d ₅	d ₁₀	h ₁	h ₂	h ₃	h ₄	l	l ₁	l ₂	s _{air}
06	4	6	20	15	3-x-M4	72	24	45	87	31	42	1	6	36	18	400	7	0.2
08	8	12	25	20	3-x-M5	90	32	55	103	41.5	50	1.5	7	43	20	400	9	0.2
10	16	23	30	20	3-x-M6	112	42	65	130	44	58	2	9	49	20	400	12	0.2
12	32	46	40	25	3-x-M6	132	52	75	148	52.5	63.5	2	9	54.5	25	400	11.5	0.2
14	60	80	50	30	3-x-M8	145	52	100	165	55	76	2	11	65	30	400	12	0.3
16	80	125	55	38- ¹⁾	3-x-M8	170	52	100	200	70	83	2.25	11	72	30	600	15	0.3
18	150	235	85	45	6-x-M8	196	62	115	221	77	94	2.75	11	83	35	600	14	0.4

■ M_k: Rated torque of the brake in Nm at n = 100 rpm

■ P₂₀: Coil power at 20 °C in W

■ ¹⁾ Standard keyway to DIN 6885/1-P9

■ All dimensions in mm

Technical data

Rated data

Size	p ¹⁾ [W] [20°C]	Sairmax service brake [mm]	Sairmax holding brake [mm]	J _{plastic rotor} [kgcm ²]	J _{alu rotor} [kgcm ²]	Mass of stator Assembly [kg]
06	20	0.5	0.3	0.11	0.15	0.75
08	25	0.5	0.3	0.34	0.61	1.2
10	30	0.5	0.3	-	2.0	2.1
12	40	0.5	0.3	-	4.5	3.5
14	50	0.75	0.45	-	6.3	5.2
16	55	0.75	0.45	-	15	7.9
18	85	1.0	0.6	-	29	12

1) Coil power at 20°C in W, possible deviation up to +10%, depending on supply voltage selected

Braking torques, depending on speed and permissible limit speeds

Size	Average braking torque when decelerating from Δn_0 to a standstill [%]	Braking torque at Δn_0 [rpm]			Max. speed Δn_{0max} [rpm]
		1,500 [%]	3,000 [%]	max. [%]	
06	100	87	80	74	6000
08	100	85	78	73	5000
10	100	83	76	73	4000
12	100	81	74	73	3600
14	100	80	73	72	3600
16	100	79	72	70	3600
18	100	77	70	68	3600

As speed increases, so does wear

Rotor with plastic sleeve

The rotor with plastic sleeve offers numerous advantages and reduces rattling noise in the rotor/hub connection. The tried-and-tested involute gear, which has been proving its worth for many years, safeguards the stability of the rotor/hub connection. The plastic sleeve reduces backlash, thereby increasing the service life of the brake.

Features and advantages

- Low-backlash power transmission between shaft and rotor
- Long service life thanks to involute gear and long rotor neck
- Low wear between rotor and hub thanks to low backlash
- Recommended for frequency inverter operation
- Noise-reduced design



Technical data

Operating times

The listed operating times are guide values which apply to DC switching with rated air gap s_{air} , warm coil and standard characteristic torque. The times shown are mean values. The

engagement time t_1 is approximately 8 to 10 times longer for AC switching.

Torque time characteristic, dependent on excitation voltage

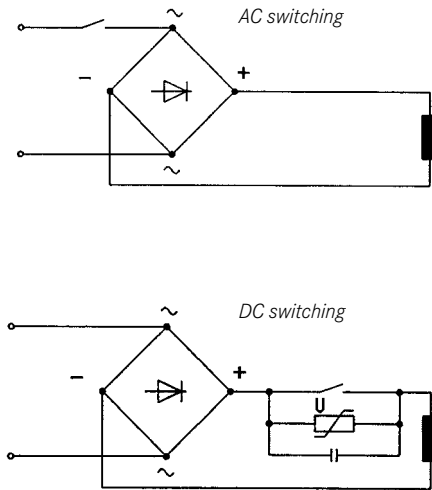
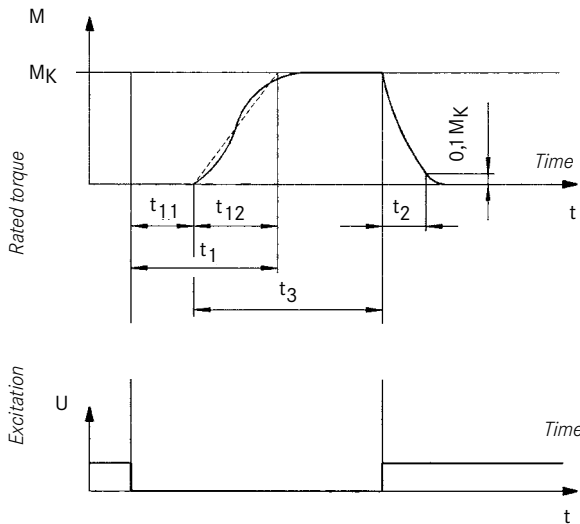

Explanations

- t₁** [s] Engagement time, $t_1 = t_{11} + t_{12}$
- t₂** [s] Disengagement time (time from the beginning of the torque drop until 0.1 M is reached)
- t₃** [s] Slipping time (time during which a relative movement occurs between drive and output with brake applied)
- t₁₁** [s] Delay time (time from disconnecting the voltage until the torque begins to rise)
- t₁₂** [s] Rise time of braking torque
- Q_{perm}** [J] Max. permissible friction energy per switching cycle
- S_h** [h⁻¹] Operating frequency, i.e. the number of periodical brake operations
- S_{air}** Rated air gap

Size	Braking torque rated value at $\Delta n=100$ rpm $M_K^{(1)}$ [Nm]	Maximum permissible switching energy with single operating Q_E [J]	Transition operating frequency S_{air} [h ⁻¹]	Operating times [ms] ²⁾ at S_{air}			Disengagement [t ₂]
				Engagement on DC side [t ₁₁]	[t ₁₂]	[t ₁]	
06	4	3000	79	14	30	44	62
08	8	7500	50	39	27	66	61
10	16	12000	40	29	41	70	100
12	32	24000	30	40	38	78	150
14	60	30000	28	36	50	86	300
16	80	36000	27	30	45	75	330
18	150	60000	20	68	67	135	320

¹⁾ Minimum braking torque for run-in friction pairs.
²⁾ Operating times valid for 205 V DC coils

Technical data

Service life and wear

The friction energy to be withstood until s_{airmax} is reached is dependent on a number of factors: in particular, the inertias to be braked, the braking speed, the operating frequency and the resulting temperature on the friction surfaces. For this reason, no universal value for all operating conditions can be given in respect of the amount of friction energy that can be handled.

In addition, increased wear should be expected with vertical mounting.

When the maximum permissible working air gap (s_{airmax}) is reached, the rotor must be replaced.

Where the amount of friction energy per switching operation is low, the brake's mechanical components can impose limitations in terms of service life. In particular, the rotor/hub connection, springs, armature plate and sleeves are subject to operational wear. The expected service life of the standard design is around 1 million load alternations. Solutions that are optimised in terms of service life are available in cases where a longer service life is required (consult the manufacturer).

Maintenance

Brakes are components which are subject to a great deal of wear. When installing the brake, it must be ensured that it can be easily accessed for inspection and maintenance purposes. Intervals between inspections should be set in accordance with the expected service life and load. For more information, please see the Operating Instructions.

Permissible friction energy Q_{perm} depending on operating frequency S_h

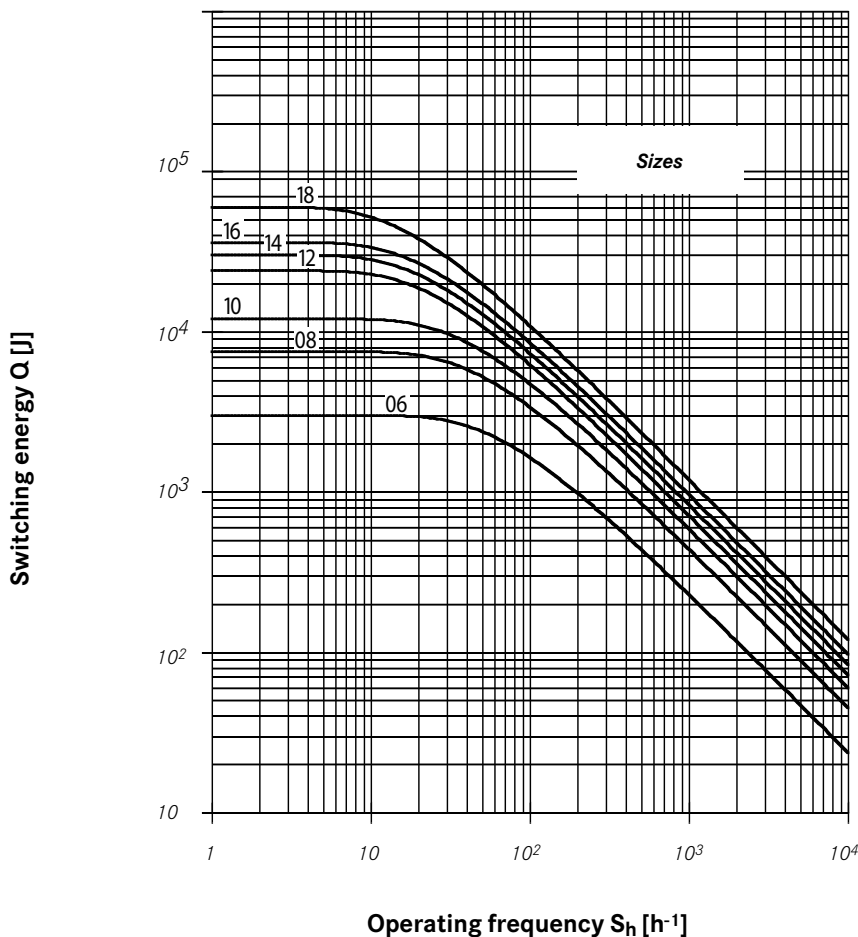

Model overview

INTORQ BFK46 1-□□□

Complete stator

Size	<ul style="list-style-type: none"> ■ 06 ■ 08 ■ 10 ■ 12 ■ 14 ■ 16 ■ 18
Design	<ul style="list-style-type: none"> ■ With flange ■ Without flange
Brake voltage	<ul style="list-style-type: none"> ■ 24 V ■ 103 V ■ 180 V ■ 205 V
Braking torque	<ul style="list-style-type: none"> ■ Nm (see torque ratings)
Cable length	<ul style="list-style-type: none"> ■ Standard <p>(from 100 mm to 1000 mm in 100 mm steps, from 1000 mm to 2500 mm in 250 mm steps)</p>

Accessories

Rotor	<ul style="list-style-type: none"> ■ Standard ■ Noise-reduced (rotor with sleeve)
Hub	(for bore diameter, see Dimensions)
Fixing screw set	<ul style="list-style-type: none"> ■ For mounting onto the flange ■ For mounting on the motor
Sealing of the back wall of the housing	<ul style="list-style-type: none"> ■ Shaft sealing ring (shaft diameter on request) ■ Cap

Electrical accessories

Bridge rectifier	<ul style="list-style-type: none"> ■ 4-pole without snap-in stud ■ 4-pole with snap-in stud ■ 6-pole vertical, integrated spark suppressor ■ 6-pole horizontal, integrated spark suppressor
Half-wave rectifier	<ul style="list-style-type: none"> ■ 4-pole without snap-in stud ■ 4-pole with snap-in stud ■ 6-pole vertical, integrated spark suppressor ■ 6-pole horizontal, integrated spark suppressor
Spark suppressor	<ul style="list-style-type: none"> ■



INTORQ – Sales and Service around the world

INTORQ customers can reach us at any time and from anywhere in the world. Our Key Account Sales Team looks after key account customers and project business.

In addition, we co-operate with Lenze's global sales organisation. You can contact us via Lenze Service by calling the 24-hour helpline (008000 24 46177).

INTORQ GmbH & Co. KG

PO Box 1103
D-31849 Aerzen, Germany

Wülmser Weg 5
D-31855 Aerzen

Tel.: +49 (0)5154 9539-01

Fax: +49 (0)5154 9539-10

E-mail: info@intorq.de

www.intorq.de

INTORQ

setting the standard

www.intorq.de