



Multi-pole spring-applied brake INTORQ BFK466 for braking torques up to 9000 Nm

Disc brake with spring force in redundant arrangement, modular structure, can be expanded

Features

■ **Powerful**

High braking torque and large working air gap

■ **Low-noise operation**

Release without residual torque and quiet operation

■ **Compact**

Contours adapt perfectly to the motor design

■ **High energy density**

High magnetic forces caused by overexcitation

■ **Low energy consumption**

"Cold brake" through holding current derating

■ **Safe**

Air gap or wear monitoring using microswitch

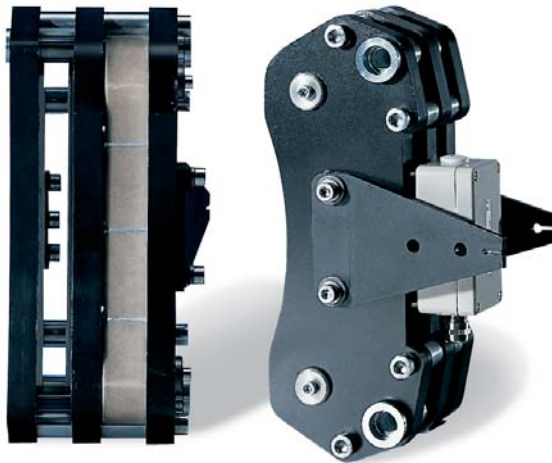

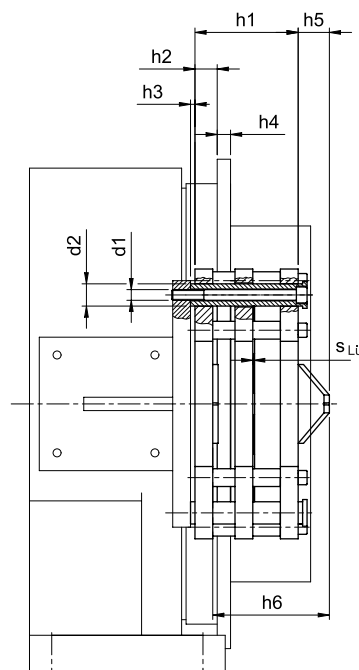
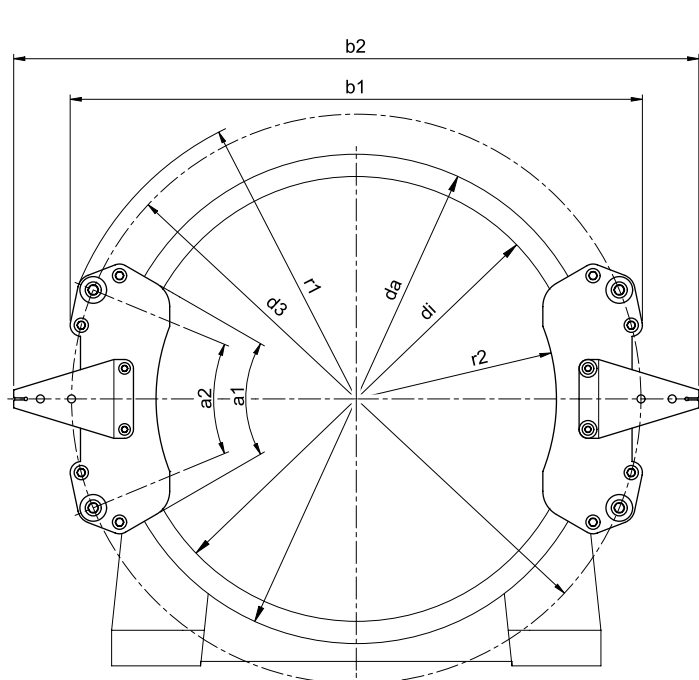

Design	M_K^{*1} (Nm)	P_{20} (W) Switch/ hold	b1	b2 (approx.)	da	di	d1	d2	d3	h1	h2	h3	h4	h5 (approx.)	h6 (approx.)	r1	r2	S_{air}	a1	a2
1	450	353/88	510	-	430	360	M10	20	520	108	19	5	15	-	-	275	182.5	0.4	66.5°	50°
2	460	367/92	890	-	810	760	M10	20	890	145	20	22	67	-	-	457	350	0.4	28°	26.8°
3	640	330/83	746	917	690	590	M12	25	740	102.5	25	5	10	26	114	385	288	0.5	49°	37.5°
4	925	473/118	643	770	550	500	M12	25	640	116	25	5	15	25	121	337.5	225	0.5	60°	45°
5	1800	930/233	780	-	690	600	M16	25	745	133	25	5	20	-	-	390	255	0.5	57°	40°

* Characteristic torque per calliper related to the relative speed
 $\Delta n = 100$ rpm

(Redundancy by using at least 2 callipers)