

Features:

- ❑ DC braking with one-way rectification
- ❑ suitable for all asynchronous motors and for mono phase motors
- ❑ controlled by microcontroller
- ❑ easy mounting, also for retrofitting into existing plants
- ❑ wear-resistant and maintenance-free
- ❑ integrated braking contactor
- ❑ printed circuit-board version with fault signalling contact
- ❑ for snap-on mounting onto 35mm DIN rail
- ❑ degree of protection: case version IP 20, printed circuit-board version (LP) IP 00
- ❑ meets trade assoc. requirements for category 2 acc. to EN 954-1 according to the test principles of woodworking machines GS-HO-01



Braking Devices
VB 230-6/25/30L (LP)
VB 400-6/25/30L (LP)



Function:

- ❑ start braking via detection of motor voltage and via motor contactor (double safety)
- ❑ overload protection
- ❑ braking current cutoff after motor standstill
- ❑ braking current control
- ❑ automatic remanence time optimization
- ❑ braking current infinitely adjustable 10-100%
- ❑ potential-free output for motor contactor interlocking during braking; also usable to energize the star contactor during braking
- ❑ standstill threshold adjustable; individual adaptable to different motor types

Typical Applications:

- sawing machines
- centrifuges
- wood working machines
- textile machines
- conveying systems

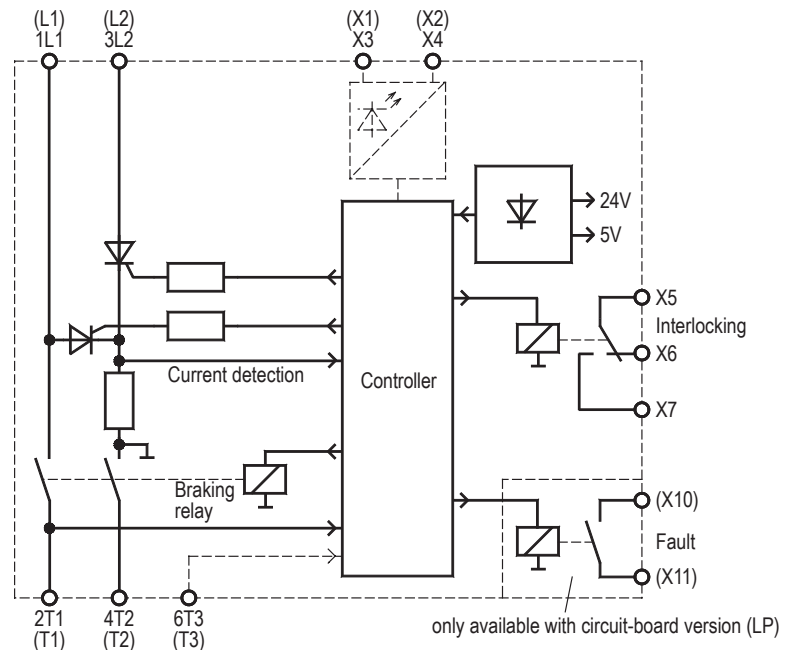

Type designation	VB 230-6L	VB 230-25L	VB 230-30L	VB 400-6L	VB 400-25L	VB 400-30L
Mains voltage Acc. to DIN EN 50160 (IEC 38)	220/240V ±10% 50/60Hz			380/415V ±10% 50/60Hz		
Power draw of electronics	3 VA					
Recommended for rated motor currents up to	0,3 ... 3A	2 ... 12,5A	2 ... 15A	0,3 ... 3A	2 ... 12,5A	2 ... 15A
Rated device current	6A	25A	30A	6A	25A	30A
max. Braking frequency at a braking time of 5s	1/8s	1/60s	1/90s	1/8s	1/60s	1/90s
I ² t-value of power semiconductors	310A ² s	1250A ² s	1350A ² s	310A ² s	1250A ² s	1350A ² s
Braking voltage	0 ... 110VDC			0 ... 220VDC		
max. Braking time	12s					
Contact rating (control relay)	3A/250V					
Delay time for reduction of residual e.m.f.	Self-optimizing in the range between 0,2 ... 2s					
max. Cross-sectional area for connection	2x 2,5mm ² per terminal					
Ambient / Storage temperature	0°C ... 45°C / -25°C ... 75°C					
Weight	0,6kg					
Order number case version (L)	2B000.23006	2B000.23025	2B000.23030	2B000.40006	2B000.40025	2B000.40030
Order number printed circuit-board version (LP)	2B100.23006	2B100.23025	2B100.23030	2B100.40006	2B100.40025	2B100.40030

Please observe supplementary sheet with dimensioning rules.

Dimensions:

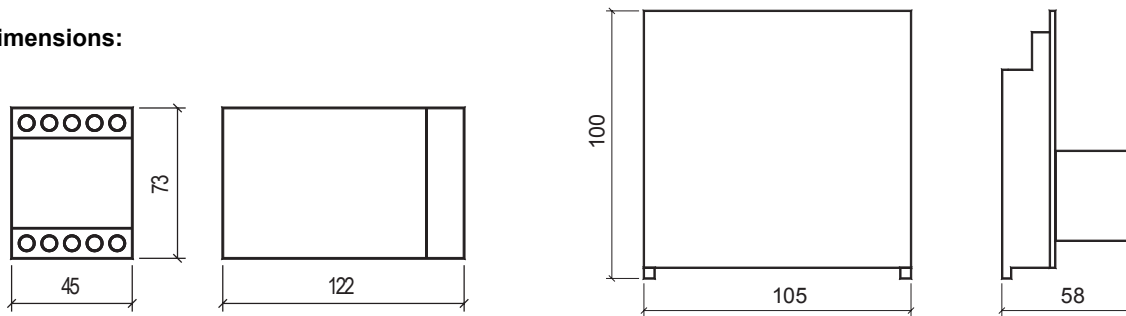

case version

printed circuit-board version (LP)

Connection Diagram:

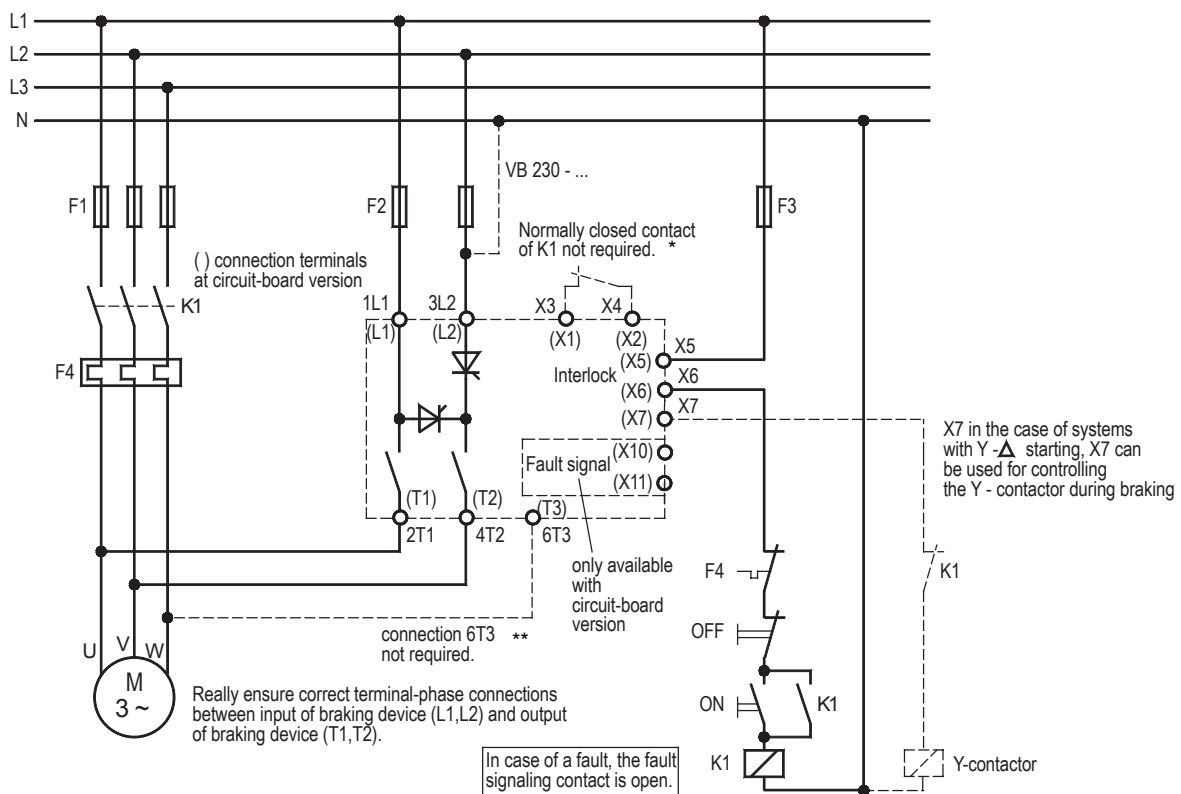

EMC

The limit values for emitted interference according to the applicable device standards do not rule out the possibility that receivers and susceptible electronic devices within a radius of 10m are subjected to interference. If such interference, which is definitely attributable to the operation of the braking devices "VB", occurs, the emitted interference can be reduced by taking appropriate measures. Such measures are, e.g.:

To connect reactors (3mH) or a suitable mains filter in series before the braking device, or to connect X-capacitors (0.15 μ F) in parallel to the supply voltage terminals.

Functional description:

- * Connection of X3, X4 will only be needed if double security for the start of braking is required.
- ** Connection of 6T3 is only necessary with very short standstill times of motor (<3s). If 6T3 is not connected and a motor standstill is detected within 3s, the braking current is switched off after the security time. Therefore a failure is monitored.