

**Features:**

- ❑ DC braking with one-way rectification
- ❑ controlled by microcontroller
- ❑ suitable for all asynchronous motors
- ❑ easy mounting, also for retrofitting into existing plants
- ❑ wear-resistant and maintenance-free
- ❑ integrated braking contactor (devices up to 60A)
- ❑ degree of protection IP 20



Braking Devices  
VB 230/400-40 ... 600

CE UL in preparation

**Function:**

- ❑ control via motor contactor
- ❑ standstill- or time-dependent braking
- ❑ signalling relay for exceeded braking times
- ❑ braking current adjustments 0...100%, current control
- ❑ automatic remanence time optimization
- ❑ braking times 0.5 – 320s
- ❑ temperature monitoring of heat sink
- ❑ potential-free signalling and control outputs
- ❑ 2nd braking time 0.5 – 40s selectable
- ❑ manual braking stop selectable

**Typical Applications:**

- sawing machines
- centrifuges
- wood working machines
- textile machines
- conveying systems

**Options:**

- ❑ braking current display (AC\*)
- ❑ wide voltage range 200 – 690V (BC\*)
- ❑ plug-in control terminals (C)
- ❑ motor temperature monitoring (PC\*)
- ❑ star-delta starting control (PC\*)
- ❑ standstill signalling relay (PC\*)
- ❑ braking current monitoring (PC\*)
- ❑ Adaptor for braking devices 40A - 200A for mounting onto DIN rail (order number 29000.29700)

\* Devices with options are always equipped with pluggable control terminals.

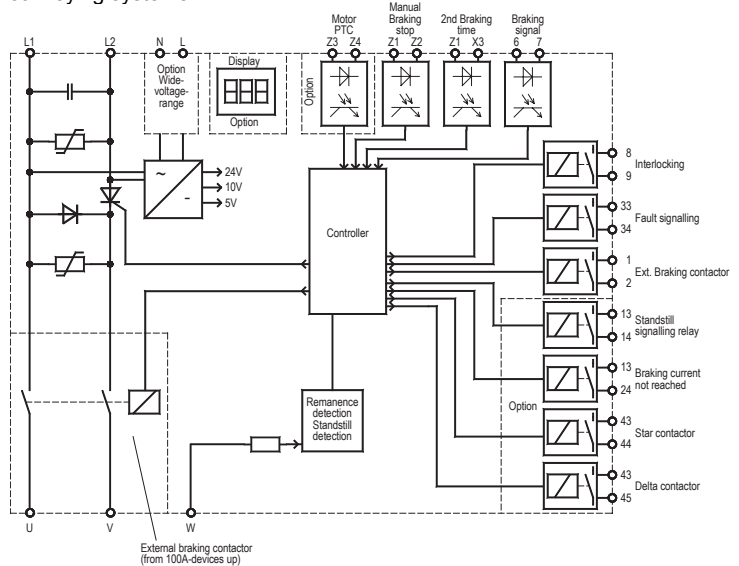

Type designation VB ...	230-40 400-40	230-60 400-60	230-100 400-100	230-200 400-200	230-400 400-400	230-600 400-600
Mains voltage according to DIN EN 50160 (IEC 38)	220/240V ±10% 50/60Hz (standard) 380/415V ±10% 50/60Hz (standard) 200 – 690V ±10% 50/60Hz (wide voltage range)					
Power draw of the electronics	6 VA					
Recommended for rated motor currents up to	20A	30A	50A	100A	200A	300A
Rated device current	40A	60A	100A	200A	400A	600A
c.d.f. at max. braking current	20%					
I <sup>2</sup> t-Value Power semiconductor	1050A <sup>2</sup> s	4900A <sup>2</sup> s	6050A <sup>2</sup> s	80000A <sup>2</sup> s	320000A <sup>2</sup> s	1125000A <sup>2</sup> s
Braking voltage	0 ... 130VDC at 220/240V 0 ... 220VDC at 380/415V					
max. Braking time	40s with standstill-dependent braking 320s with time-dependent braking					
Contact rating of output relays	3A/250V AC 3A/30V DC					
Delay time for reduction of residual e.m.f.	self-optimizing (200 ... 3100ms)			self-optimizing (1600 ... 3100ms)		
max. Cross-sectional area	16mm <sup>2</sup>	16mm <sup>2</sup>	16mm <sup>2</sup>	35mm <sup>2</sup>	Screw M12	
Ambient / Storage temperature	0°C ... 45°C / -25°C ... 75°C					
Weight	2.1kg	2.1kg	2.1kg	3.1kg	7,2	10,2
Order number 230V	29700.23040	29700.23060	29700.23100	29700.23200	29700.23400	29700.23600
Order number 400V	29700.40040	29700.40060	29700.40100	29700.40200	29700.40400	29700.40600
Order number 230V - UL	29600.23040	29600.23060	29600.23100	29600.23200	29600.23400	29600.23600
Order number 400V - UL	29600.40040	29600.40060	29600.40100	29600.40200	29600.40400	29600.40600

Please observe supplementary sheet with dimensioning rules.

Dimensions:

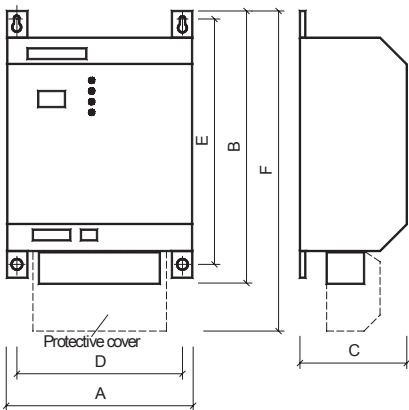

	A	B	C	D	E	F
VB ... -40	110	242	140	86	226	
VB ... -60	110	242	140	86	226	
VB ... -100	110	242	140	86	226	
VB ... -200	110	247	155	80	226	
VB ... -400	210	275	165	180	226	340
VB ... -600	210	280	165	180	226	355

All dimensions in mm.

Connection Diagrams:

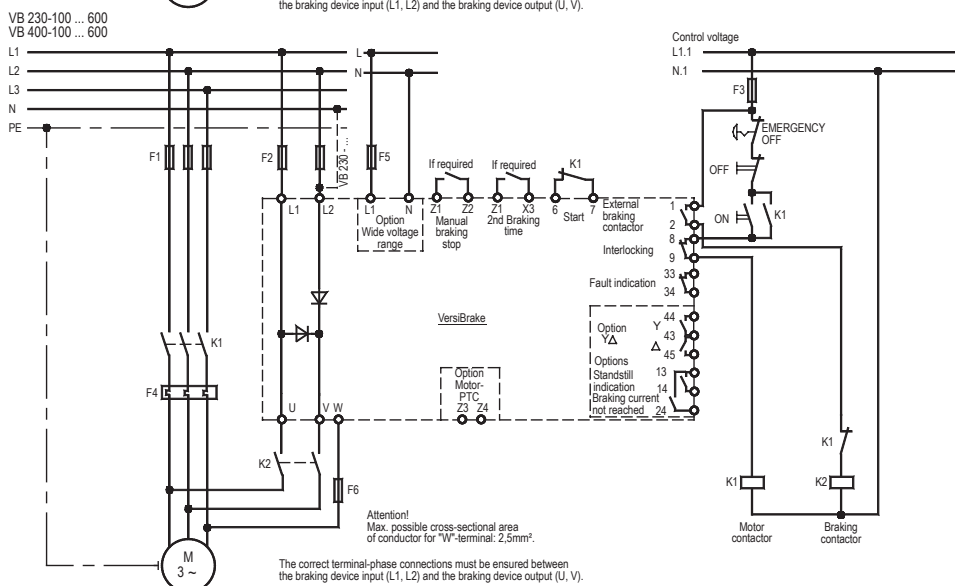
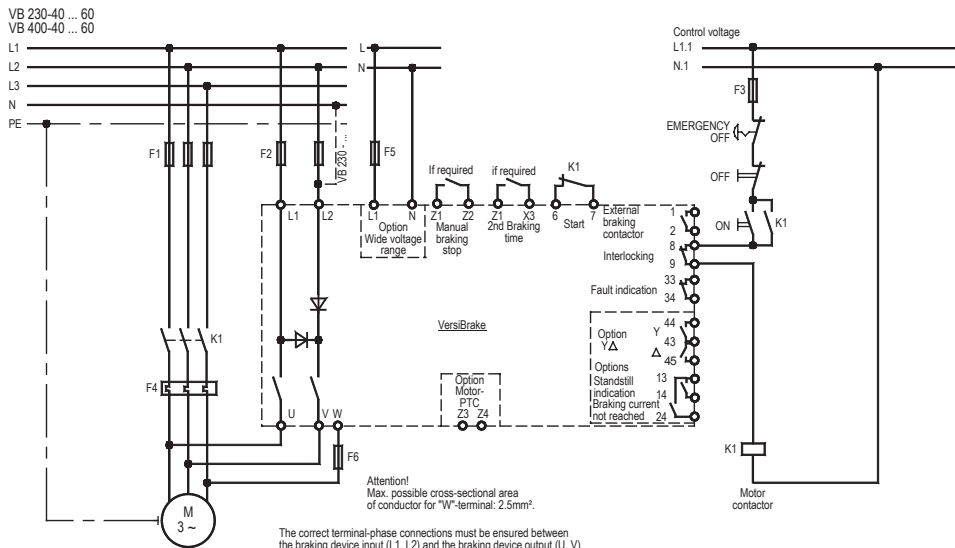

**EMC**  
The limit values for emitted interference according to the applicable device standards do not rule out the possibility that receivers and susceptible electronic devices within a radius of 10m are subjected to interference. If such interference, which is definitely attributable to the operation of the braking devices "VB", occurs, the emitted interference can be reduced by taking appropriate measures.  
Such measures are, e.g.:  
To connect reactors (3mH) or a suitable mains filter in series before the braking device, or to connect X-capacitors (0.15µF) in parallel to the supply voltage terminals.