



# MOTOR MAC QI 100 S

- Hoja de Datos Técnicos -  
- Technical Datasheet -

Codigo DT-QI100S  
Edición 08  
Página 1/2  
Fecha 19/03/2015

<b>Ventilador / Fan</b>		Rodamientos Bearings	Delantero Drive End	6308 ZZ C3	Trasero Non Drive End	6207 ZZ C3	
Tipo de Refrigeración Cooling Mode	IC 06	Nº de polos No. of poles	4	Momento de inercia Rotor Inertia	J = 0,011 Kg m <sup>2</sup>	Peso Motor Motor Weight	50 Kg
Alimentación / Supply	400 V 50Hz	Protección Protection Degree	IP 23	Construcción Mounting	IM B3 / B35	Equilibrado grado Balancing degree	A
Potencia / Power	0,25 kW	Nivel de ruido Noise Level	< 70 dB	Velocidad máxima mecánica Max. Mechanical Speed	7500 rpm		
Corriente / Current	0,71 A	Aislamiento Clase Insulation Class	F	Protección Térmica Thermal Protection	PTC 140 °C	Ambiente Ambient	< 40 °C < 1000 m
Velocidad / Speed	2800 rpm	Normas de referencia Reference Standards	EN60034		Conmutación Variador Inverter Switching	4 kHz ; du/dt TS60034-25 Type B	
Caudal / Air flow	570 m3/h	Por favor, indicar en los pedidos la alimentación deseada para el ventilador / Please indicate the required fan supply voltage when placing your order					
Presión / Pressure	450 Pa	<b>Freno de Bloqueo (opcional) Holding Brake (optional)</b>					
		60 Nm	24 Vdc	2.1 A	50 W	5.6 Kg	J = 0.00063 Kg m <sup>2</sup>
Tensión de Base del Motor Motor Base Voltage		Vb	400 V		Tensión Máxima de Salida del Convertidor Inverter max. Output Voltage	Vc	400 V

Bobinado Winding	Servicio / Service S1						Servicio / Service S6 - 40%						Corriente en vacío No Load Current (A)
	Nm	A	KW	rpm	Hz	Velocidad a Pot.Cte Const. Power Speed. (rpm)	Nm	A	KW	rpm	Hz	Velocidad a Pot.Cte Const. Power Speed. (rpm)	
111	38	8,1	3,0	745	27	1670	56	11	4,3	745	28	1240	4,3
211	38	10,4	4,3	1072	38	2410	56	14	6,3	1072	39	1790	5,4
112	38	13,4	5,7	1433	50	3220	56	18	8,4	1433	51	2390	7,2
121	38	15,4	6,7	1673	58	3760	56	21	9,8	1673	59	2800	8,3
212	38	17,6	7,8	1972	68	4430	56	24	11,5	1972	69	3300	9,4
221	38	20,3	9,2	2302	79	5170	56	27	13,4	2302	80	3840	10,7
122	38	26,2	12,1	3052	104	6860	56	35	17,8	3052	105	5100	13,8
222	38	35,1	16,3	4102	139	7500	56	47	23,9	4102	140	6850	18,7

Otras Velocidades disponibles bajo consulta a nuestra O.T. / Other speeds available on request

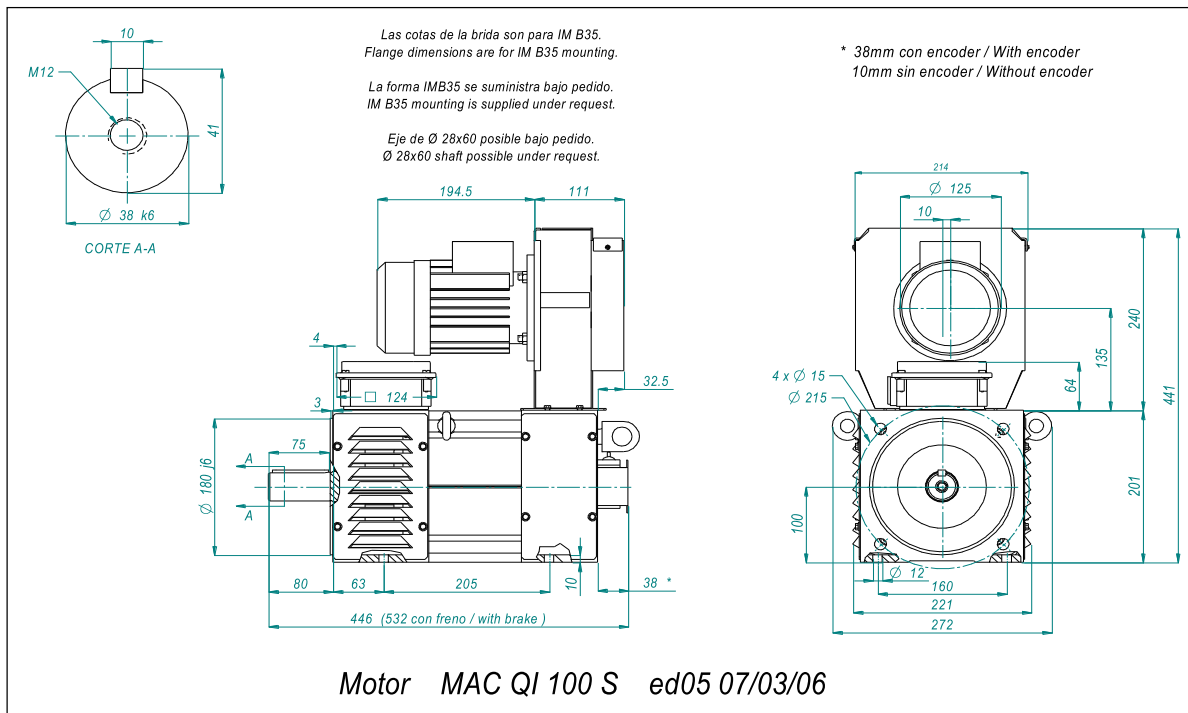

Datos Técnicos sujetos a modificaciones sin previo aviso / Technical Data are subject to changes without prior notice

Elabora: <b>David Gil</b> 18/05/2015 15:58:55	Revisa: <b>Jordi Trullen</b> 18/05/2015 18:07:08	Aprueba: <b>Jordi Trullen</b> 18/05/2015 18:07:19
---	--	---



# MOTOR MAC QI 100 M

- Hoja de Datos Técnicos -  
- Technical Datasheet -

Codigo DT-QI100M  
Edición 08  
Página 1/2  
Fecha 19/03/2015

<b>Ventilador / Fan</b>		Rodamientos Bearings	Delantero Drive End	6308 ZZ C3	Trasero Non Drive End	6207 ZZ C3	
Tipo de Refrigeración Cooling Mode	IC 06	Nº de polos No. of poles	4	Momento de inercia Rotor Inertia	J = 0,015 Kg m <sup>2</sup>	Peso Motor Motor Weight	60 Kg
Alimentación / Supply	400 V 50Hz	Protección Protection Degree	IP 23	Construcción Mounting	IM B3 / B35	Equilibrado grado Balancing degree	A
Potencia / Power	0,25 kW	Nivel de ruido Noise Level	< 70 dB	Velocidad máxima mecánica Max. Mechanical Speed	7500 rpm		
Corriente / Current	0,71 A	Aislamiento Clase Insulation Class	F	Protección Térmica Thermal Protection	PTC 140 °C	Ambiente Ambient	< 40 °C < 1000 m
Velocidad / Speed	2800 rpm	Normas de referencia Reference Standards	EN60034		Conmutación Variador Inverter Switching	4 kHz ; du/dt TS60034-25 Type B	
Caudal / Air flow	570 m <sup>3</sup> /h	Por favor, indicar en los pedidos la alimentación deseada para el ventilador / Please indicate the required fan supply voltage when placing your order					
Presión / Pressure	450 Pa	<b>Freno de Bloqueo (opcional) Holding Brake (optional)</b>					
		60 Nm	24 Vdc	2.1 A	50 W	5.6 Kg	J = 0.00063 Kg m <sup>2</sup>
Tensión de Base del Motor Motor Base Voltage		Vb	400 V		Tensión Máxima de Salida del Convertidor Inverter max. Output Voltage		Vc 400 V

Bobinado Winding	Servicio / Service S1						Servicio / Service S6 - 40%						Corriente en vacío No Load Current (A)
	Nm	A	KW	rpm	Hz	Velocidad a Pot.Cte Const. Power Speed. (rpm)	Nm	A	KW	rpm	Hz	Velocidad a Pot.Cte Const. Power Speed. (rpm)	
111	52	10,7	4,1	746	27	1710	76	15	6,0	746	28	1270	5,6
211	52	14,1	5,9	1075	38	2470	76	19	8,6	1075	39	1830	7,4
112	52	17,7	7,7	1406	49	3230	76	24	11,2	1406	50	2400	9,5
121	52	20,2	9,1	1673	58	3840	76	27	13,4	1673	59	2850	10,4
212	52	23,8	10,7	1975	68	4540	76	32	15,8	1975	69	3380	12,8
221	52	27,6	12,5	2305	79	5300	76	37	18,4	2305	80	3940	14,8
122	52	34,9	16,3	2994	102	6880	76	47	23,9	2994	103	5120	18,4
222	52	47,5	22,5	4134	140	7500	76	64	33,0	4134	141	7060	25,0

Otras Velocidades disponibles bajo consulta a nuestra O.T. / Other speeds available on request

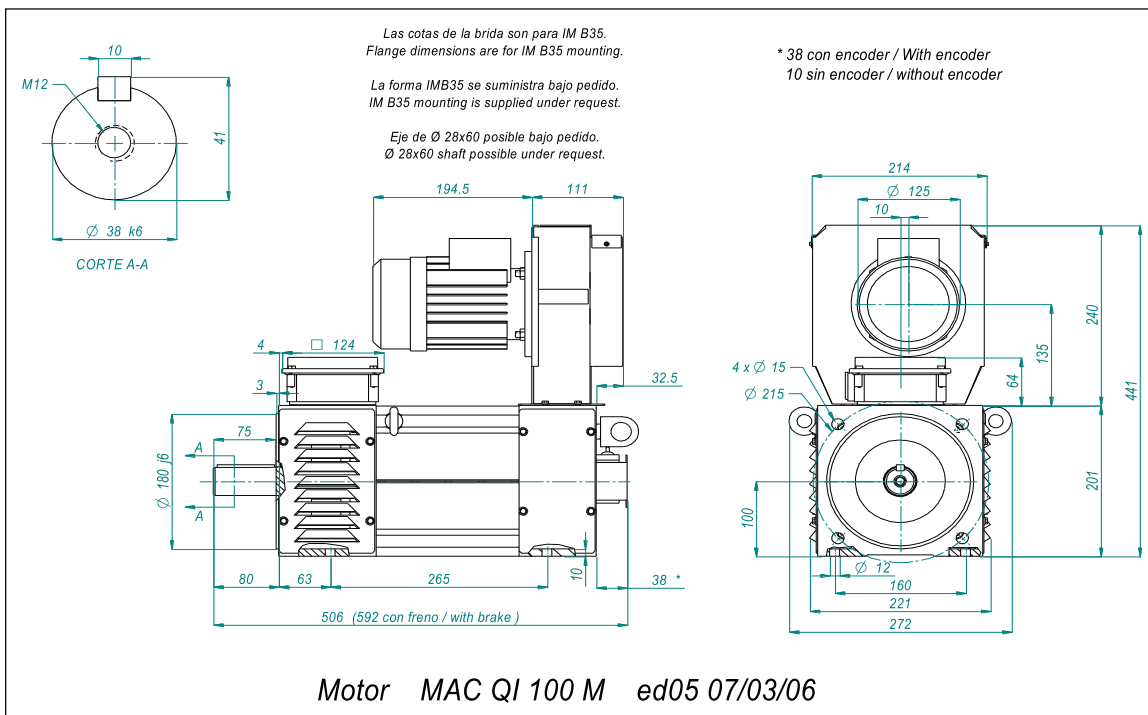

Datos Técnicos sujetos a modificaciones sin previo aviso / Technical Data are subject to changes without prior notice

Elabora: <b>David Gil</b> 18/05/2015 15:59:45	Revisa: <b>Jordi Trullen</b> 18/05/2015 18:07:38	Aprueba: <b>Jordi Trullen</b> 18/05/2015 18:07:46
---	--	---



### MOTOR MAC QI 100 L

- Hoja de Datos Técnicos -  
- Technical Datasheet -

Código DT-QI100L  
Edición 08  
Página 1/2  
Fecha 19/03/2015

<b>Ventilador / Fan</b>		Rodamientos <i>Bearings</i>	Delantero <i>Drive End</i>	6308 ZZ C3	Trasero <i>Non Drive End</i>	6207 ZZ C3	
Tipo de Refrigeración <i>Cooling Mode</i>	IC 06	Nº de polos <i>No. of poles</i>	4	Momento de inercia <i>Rotor Inertia</i>	J = 0,019 Kg m <sup>2</sup>	Peso Motor <i>Motor Weight</i>	70 Kg
Alimentación / Supply <i>Power</i>	400 V 50Hz	Protección <i>Protection Degree</i>	IP 23	Construcción <i>Mounting</i>	IM B3 / B35	Equilibrado grado <i>Balancing degree</i>	A
Potencia / Power	0,25 kW	Nivel de ruido <i>Noise Level</i>	< 70 dB	Velocidad máxima mecánica <i>Max. Mechanical Speed</i>	7500 rpm		
Corriente / Current	0,71 A	Aislamiento Clase <i>Insulation Class</i>	F	Protección Térmica <i>Thermal Protection</i>	PTC 140 °C	Ambiente <i>Ambient</i>	< 40 °C < 1000 m
Velocidad / Speed	2800 rpm	Normas de referencia <i>Reference Standards</i>	EN60034	Conmutación Variador <i>Inverter Switching</i>	4 kHz ; du/dt TS60034-25 Type B		
Caudal / Air flow	570 m <sup>3</sup> /h	Por favor, indicar en los pedidos la alimentación deseada para el ventilador / Please indicate the required fan supply voltage when placing your order					
Presión / Pressure	450 Pa	<b>Freno de Bloqueo (opcional) <i>Holding Brake (optional)</i></b>		60 Nm	24 Vdc	2.1 A	50 W
				5.6 Kg	J = 0.00063 Kg m <sup>2</sup>		
		Tensión de Base del Motor <i>Motor Base Voltage</i>		Vb	400 V		Tensión Máxima de Salida del Convertidor <i>Inverter max. Output Voltage</i>
						Vc	400 V

Bobinado <i>Winding</i>	Servicio / Service S1						Servicio / Service S6 - 40%						Corriente en vacío <i>No Load Current</i> (A)
	Nm	A	KW	rpm	Hz	Velocidad a Pot.Cte <i>Const. Power Speed</i> (rpm)	Nm	A	KW	rpm	Hz	Velocidad a Pot.Cte <i>Const. Power Speed</i> (rpm)	
111	65	14,2	5,5	810	29	1860	95	19	8,1	810	30	1380	7,7
211	65	17,0	6,9	1021	36	2340	95	23	10,2	1021	37	1740	9,5
112	65	23,6	10,4	1529	53	3510	95	32	15,2	1529	54	2610	12,9
121	65	26,9	12,2	1797	62	4130	95	36	17,9	1797	63	3070	14,2
212	65	28,5	13,0	1917	66	4400	95	39	19,1	1917	67	3270	15,1
221	65	32,9	15,1	2218	76	5100	95	44	22,1	2218	77	3790	17,6
122	65	46,5	21,8	3208	109	7370	95	63	32,0	3208	110	5490	25,0
222	65	56,8	26,9	3958	134	7500	95	77	39,5	3958	135	6770	30,3

Otras Velocidades disponibles bajo consulta a nuestra O.T. / Other speeds available on request

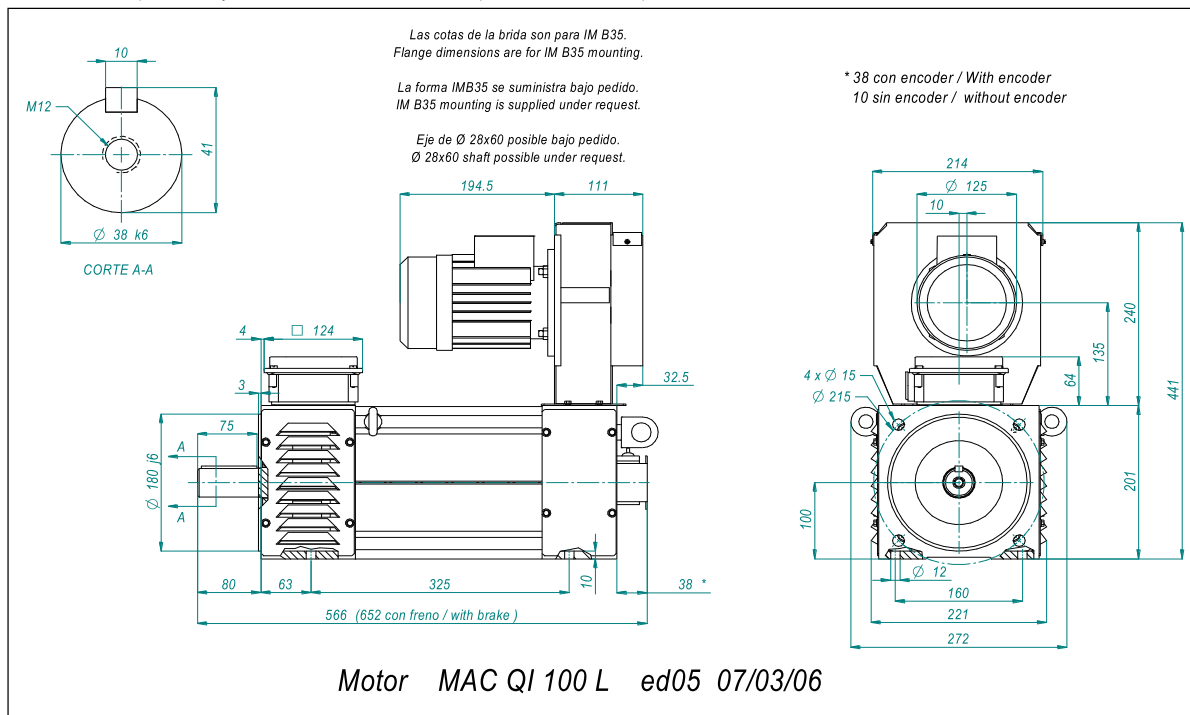

Datos Técnicos sujetos a modificaciones sin previo aviso / Technical Data are subject to changes without prior notice

Elabora: <b>David Gil</b> 18/05/2015 16:00:31	Revisa: <b>Jordi Trullen</b> 18/05/2015 18:08:02	Aprueba: <b>Jordi Trullen</b> 18/05/2015 18:08:11
---	--	---

<b>Ventilador / Fan</b>		Rodamientos <i>Bearings</i>		Delantero <i>Drive End</i>		Trasero <i>Non Drive End</i>	
Tipo de Refrigeración <i>Cooling Mode</i>		IC 06		6310 ZZ C3		6208 ZZ C3	
Alimentación / Supply		Nº de polos <i>No. of poles</i>		Momento de inercia <i>Rotor Inertia</i>		Peso Motor <i>Motor Weight</i>	
Potencia / Power		4		J = 0,046 Kg m <sup>2</sup>		95 Kg	
Corriente / Current		Protección <i>Protection Degree</i>		Construcción <i>Mounting</i>		Equilibrado grado <i>Balancing degree</i>	
Velocidad / Speed		IP 23		IM B3 / B35		A	
Caudal / Air flow		Nivel de ruido <i>Noise Level</i>		Velocidad máxima mecánica <i>Max. Mechanical Speed</i>		6000 rpm	
Presión / Pressure		< 80 dB		6000 rpm			
Por favor, indicar en los pedidos la alimentación deseada para el ventilador / Please indicate the required fan supply voltage when placing your order		Aislamiento Clase <i>Insulation Class</i>		Protección Térmica <i>Thermal Protection</i>		Ambiente <i>Ambient</i>	
		F		PTC 140 °C		< 40 °C < 1000 m	
		Normas de referencia <i>Reference Standards</i>		Conmutación Variador <i>Inverter Switching</i>		4 kHz ; du/dt TS60034-25 Type B	
		EN60034					
<b>Freno de Bloqueo (opcional) <i>Holding Brake (optional)</i></b>		150 Nm		24 Vdc		3,5 A	
		85 W		12 Kg		J = 0.0029 Kg m <sup>2</sup>	
Tensión de Base del Motor <i>Motor Base Voltage</i>		Vb		400 V		Tensión Máxima de Salida del Convertidor <i>Inverter max. Output Voltage</i>	
						Vc	
						400 V	

Bobinado <i>Winding</i>	Servicio / Service S1						Servicio / Service S6 - 40%						Corriente en vacío <i>No Load Current (A)</i>
	Nm	A	KW	rpm	Hz	Velocidad a Pot.Cte Const. Power Speed. (rpm)	Nm	A	KW	rpm	Hz	Velocidad a Pot.Cte Const. Power Speed. (rpm)	
111	100	9,9	4,0	379	14	680	149	14,1	5,9	379	15	500	3,8
211	100	12,7	5,4	515	19	920	148	17,9	8,0	515	19	670	5,4
112	100	16,7	7,7	739	26	1330	148	23,6	11,5	739	27	980	6,9
121	100	19,5	9,0	860	30	1540	148	27,2	13,3	860	31	1130	8,7
212	100	21,3	10,3	980	34	1760	148	30,0	15,2	980	35	1300	9,0
221	100	25,0	11,8	1131	39	2030	148	34,8	17,5	1131	40	1500	11,4
122	100	33,2	16,5	1580	54	2840	148	46,5	24,5	1580	55	2100	14,6
141	100	38,4	19,1	1821	62	3270	148	53,5	28,2	1821	63	2420	17,4
222	100	42,6	21,6	2060	70	3700	148	59,6	31,9	2060	71	2730	18,8
241	100	49,1	25,0	2390	81	4300	148	68,8	37,0	2390	82	3170	21,4
142	100	66,0	34,4	3289	111	5920	148	93,0	51,0	3289	112	4370	27,8

Otras Velocidades disponibles bajo consulta a nuestra O.T. / Other speeds available on request

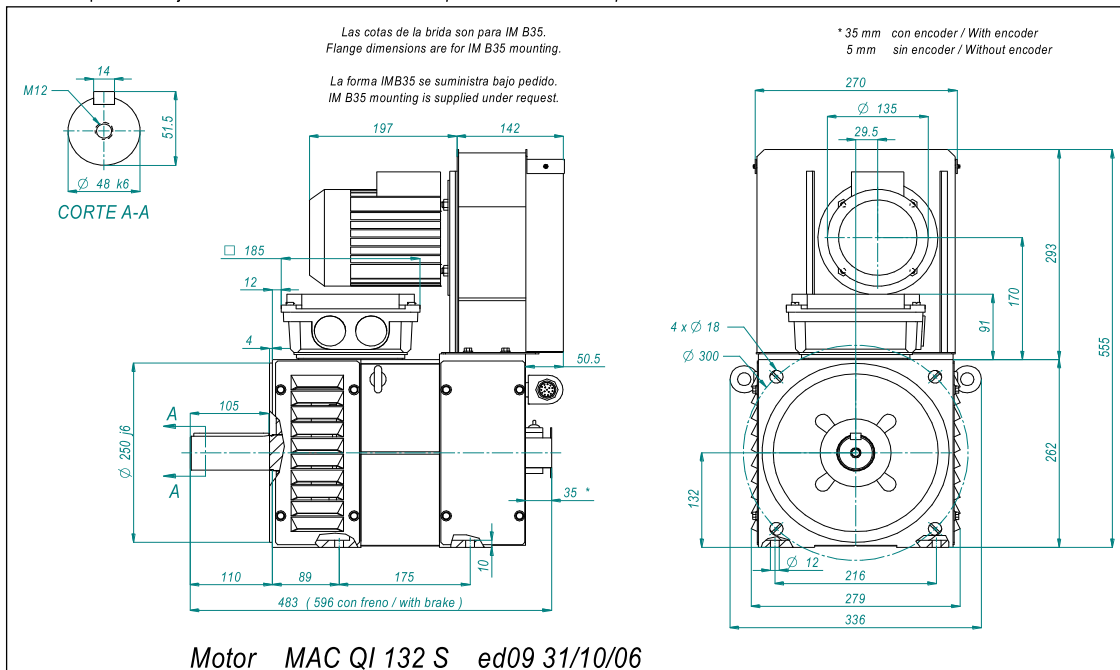

Datos Técnicos sujetos a modificaciones sin previo aviso / Technical Data are subject to changes without prior notice

Elabora: <b>David Gil</b>	15/05/2015 11:30: 16	Revisa: <b>Jordi Trullen</b>	18/05/2015 18:08:50	Aprueba: <b>Jordi Trullen</b>	18/05/2015 18:08:58
------------------------------	-------------------------	---------------------------------	---------------------	----------------------------------	------------------------



# MOTOR MAC QI 132 M

- Hoja de Datos Técnicos -  
- Technical Datasheet -

Código DT-QI132M  
Edición 13  
Página 1/2  
Fecha 24/03/2015

<b>Ventilador / Fan</b>		Rodamientos <b>Delantero</b> 6310 ZZ C3 <b>Trasero</b> 6208 ZZ C3	
Tipo de Refrigeración <b>IC 06</b>		Bearings <b>Drive End</b> <b>Non Drive End</b>	
Cooling Mode			
Alimentación / Supply 400V 50Hz		Nº de polos 4 Momento de inercia $J = 0,061 \text{ Kg m}^2$ Peso Motor 115 Kg	
Potencia / Power 0,37 KW		Rotor Inertia Motor Weight	
Corriente / Current 1,11A		Protección IP 23 Construcción IM B3 / B35 Equilibrado grado A	
Velocidad / Speed 2800 rpm		Protection Degree Mounting Balancing degree	
Caudal / Air flow 900 m3/h		Nivel de ruido < 80 dB Velocidad máxima mecánica 6000 rpm	
Presión / Pressure 680 Pa		Noise Level Max. Mechanical Speed	
Por favor, indicar en los pedidos la alimentación deseada para el ventilador / Please indicate the required fan supply voltage when placing your order		Aislamiento Clase F Protección Térmica PTC 140 °C Ambiente < 40 °C < 1000 m	
		Insulation Class Thermal Protection Ambient	
		Normas de referencia EN60034 Conmutación Variador 4 kHz ; du/dt TS60034-25 Type B	
		Reference Standards Inverter Switching	
<b>Freno de Bloqueo (opcional)</b>		150 Nm 24 Vdc 3,5 A 85 W 12 Kg J = 0.0029 Kg m <sup>2</sup>	
<b>Holding Brake (optional)</b>			
Tensión de Base del Motor <b>Vb</b> 400 V		Tensión Máxima de Salida del Convertidor <b>Vc</b> 400 V	
Motor Base Voltage		Inverter max. Output Voltage	

Bobinado Winding	Servicio / Service S1						Servicio / Service S6 - 40%						Corriente en vacío No Load Current (A)
	Nm	A	KW	rpm	Hz	Velocidad a Pot.Cte Const. Power Speed. (rpm)	Nm	A	KW	rpm	Hz	Velocidad a Pot.Cte Const. Power Speed. (rpm)	
111	140	14,2	5,6	384	14	740	207	20	8,3	384	15	540	6,4
211	140	16,9	7,8	532	19	1030	208	24	11,6	532	20	750	6,5
112	140	23,5	10,9	744	26	1450	207	33	16,1	744	27	1070	10,6
121	140	26,7	13,1	892	31	1730	208	38	19,4	892	32	1270	10,9
212	140	29,0	14,4	983	34	1910	208	41	21,4	983	35	1410	12,1
221	140	34,0	16,6	1134	39	2210	207	47	24,6	1134	40	1630	15,4
122	140	45,9	23,6	1613	55	3140	207	65	35,0	1613	56	2320	19,3
141	140	53,1	27,2	1853	63	3610	207	74	40,2	1853	64	2670	23,3
222	140	58,6	29,8	2034	69	3960	207	82	44,1	2034	70	2930	26,7
241	140	67,4	34,6	2364	80	4600	207	94	51,2	2364	81	3400	30,0
142	140	92,0	48,3	3293	111	6000	207	129	71,4	3293	112	4730	39,8

Otras Velocidades disponibles bajo consulta a nuestra O.T. / Other speeds available on request

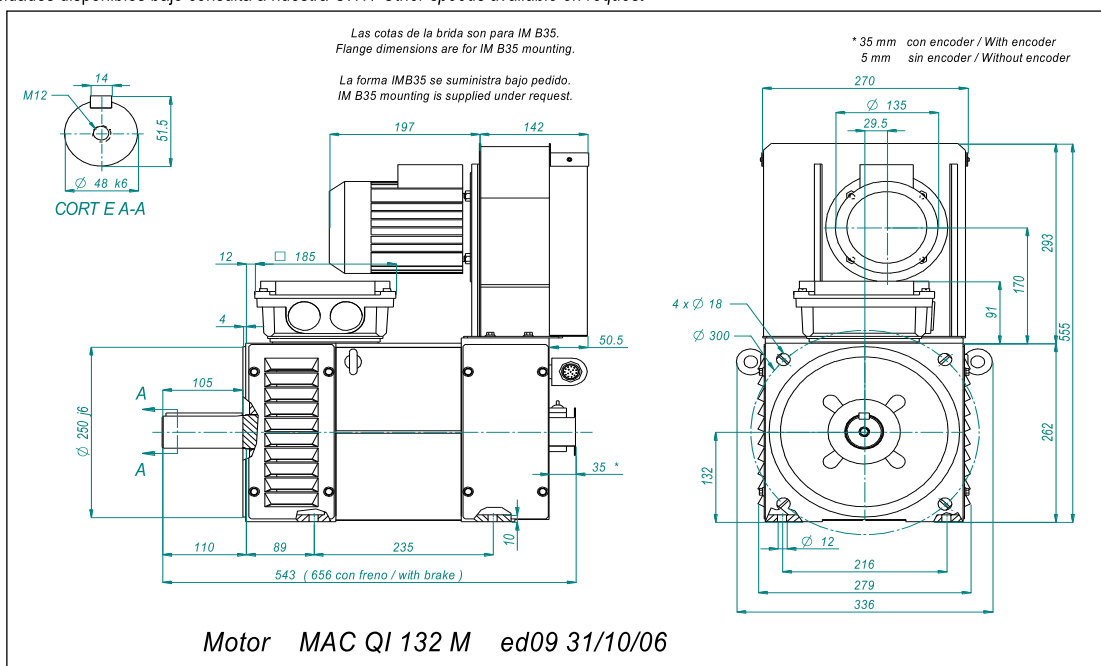

Datos Técnicos sujetos a modificaciones sin previo aviso / Technical Data are subject to changes without prior notice

Elabora: <b>David Gil</b> 15/05/2015 11:34:59	Revisa: <b>Jordi Trullen</b> 18/05/2015 18:09:14	Aprueba: <b>Jordi Trullen</b> 18/05/2015 18:09:24
---	--	---



# MOTOR MAC QI 132 L

- Hoja de Datos Técnicos -  
- Technical Datasheet -

Código DT-QI132L  
Edición 13  
Página 1/2  
Fecha 24/03/2015

<b>Ventilador / Fan</b>		Rodamientos <b>Delantero</b> 6310 ZZ C3		Trasero 6208 ZZ C3	
Tipo de Refrigeración <b>IC 06</b>		Bearings <b>Drive End</b>		<b>Non Drive End</b>	
Cooling Mode		Nº de polos 4		Momento de inercia <b>J = 0,077 Kg m<sup>2</sup></b>	
Alimentación / Supply 400V 50Hz		No. of poles		Peso Motor <b>135 Kg</b>	
Potencia / Power 0,37 KW		Protección IP 23		Construcción <b>IM B3 / B35</b>	
Corriente / Current 1,11A		Protection Degree		Mounting	
Velocidad / Speed 2800 rpm		Nivel de ruido < 80 dB		Velocidad máxima mecánica 6000 rpm	
Caudal / Air flow 900 m3/h		Noise Level		Max. Mechanical Speed	
Presión / Pressure 680 Pa		Aislamiento Clase F		Protección Térmica PTC 140 °C	
Por favor, indicar en los pedidos la alimentación deseada para el ventilador / Please indicate the required fan supply voltage when placing your order		Insulation Class		Ambiente < 40 °C < 1000 m	
		Normas de referencia EN60034		Comutación Variador 4 kHz ; du/dt TS60034-25 Type B	
<b>Freno de Bloqueo (opcional)</b>		150 Nm		24 Vdc 3,5 A 85 W 12 Kg J = 0.0029 Kg m <sup>2</sup>	
<b>Holding Brake (optional)</b>					
Tensión de Base del Motor <b>Vb 400 V</b>		Tensión Máxima de Salida del Convertidor <b>Vc 400 V</b>			
Motor Base Voltage		Inverter max. Output Voltage			

Bobinado Winding	Servicio / Service S1						Servicio / Service S6 - 40%						Corriente en vacío No Load Current (A)
	Nm	A	KW	rpm	Hz	Velocidad a Pot.Cte Const. Power Speed. (rpm)	Nm	A	KW	rpm	Hz	Velocidad a Pot.Cte Const. Power Speed. (rpm)	
111	180	17,5	7,3	386	14	810	266	24	10,8	386	15	590	7,8
211	180	23,0	10,6	564	20	1180	267	32	15,7	564	21	870	9,7
112	180	28,9	14,0	744	26	1560	267	41	20,8	744	27	1150	12,2
121	180	33,8	16,3	865	30	1810	266	47	24,1	865	31	1330	15,0
212	180	39,1	19,7	1044	36	2190	267	55	29,1	1044	37	1610	16,7
221	180	45,4	23,1	1224	42	2570	267	64	34,2	1224	43	1890	19,1
122	180	57,5	29,8	1584	54	3320	267	81	44,2	1584	55	2450	24,3
141	180	66,5	34,4	1825	62	3830	267	93	50,9	1825	63	2830	28,8
222	180	78,4	41,1	2184	74	4580	267	110	60,9	2184	75	3380	33,5
241	180	90,7	47,4	2515	85	5280	266	127	70,1	2515	86	3900	39,4
142	180	115,3	60,9	3235	109	6000	267	162	90,3	3235	110	5010	49,6

Otras Velocidades disponibles bajo consulta a nuestra O.T. / Other speeds available on request

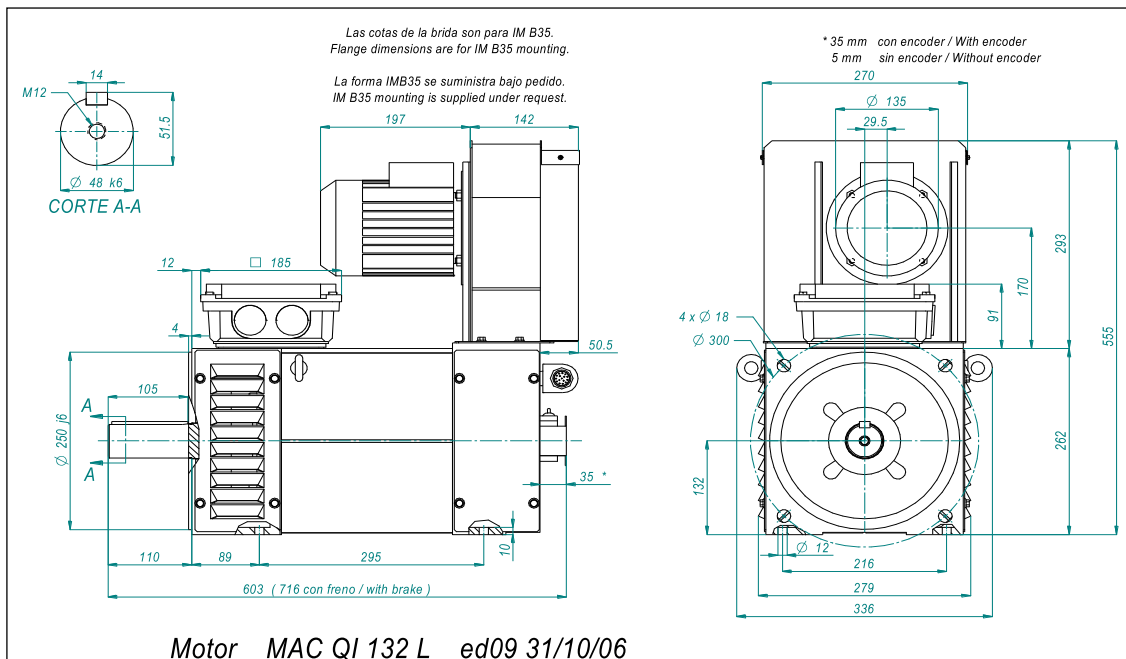

Datos Técnicos sujetos a modificaciones sin previo aviso / Technical Data are subject to changes without prior notice

Elabora: <b>David Gil</b> 15/05/2015 11:37: 13	Revisa: <b>Jordi Trullen</b> 18/05/2015 18:09:44	Aprueba: <b>Jordi Trullen</b> 18/05/2015 18:09:51
--	---	---

<b>Ventilador / Fan</b>		Rodamientos <b>Delantero</b> 6310 ZZ C3 <b>Trasero</b> 6208 ZZ C3	
Tipo de Refrigeración <b>IC 06</b>		Bearings <b>Drive End</b> <b>Non Drive End</b>	
Cooling Mode			
Alimentación / Supply 400V 50Hz		Nº de polos 4 Momento de inercia $J = 0,091 \text{ Kg m}^2$ Peso Motor 155 Kg	
Potencia / Power 0,37 KW		Rotor Inertia Motor Weight	
Corriente / Current 1,11A		Protección IP 23 Construcción IM B3 / B35 Equilibrado grado A	
Velocidad / Speed 2800 rpm		Protection Degree Mounting Balancing degree	
Caudal / Air flow 900 m3/h		Nivel de ruido < 80 dB Velocidad máxima mecánica 6000 rpm	
Presión / Pressure 680 Pa		Noise Level Max. Mechanical Speed	
Por favor, indicar en los pedidos la alimentación deseada para el ventilador / Please indicate the required fan supply voltage when placing your order		Aislamiento Clase F Protección Térmica PTC 140 °C Ambiente < 40 °C < 1000 m	
		Insulation Class Thermal Protection Ambient	
		Normas de referencia EN60034 Conmutación Variador 4 kHz ; du/dt TS60034-25 Type B	
		Reference Standards Inverter Switching	
<b>Freno de Bloqueo (opcional)</b>		150 Nm 24 Vdc 3,5 A 85 W 12 Kg J = 0.0029 Kg m <sup>2</sup>	
<b>Holding Brake (optional)</b>			
Tensión de Base del Motor <b>Vb 400 V</b>		Tensión Máxima de Salida del Convertidor <b>Vc 400 V</b>	
Motor Base Voltage		Inverter max. Output Voltage	

Bobinado Winding	Servicio / Service S1						Servicio / Service S6 - 40%						Corriente en vacío No Load Current (A)
	Nm	A	KW	rpm	Hz	Velocidad a Pot.Cte Const. Power Speed. (rpm)	Nm	A	KW	rpm	Hz	Velocidad a Pot.Cte Const. Power Speed. (rpm)	
111	220	21,4	9,5	414	15	910	327	30,4	14,2	414	16	670	8,3
211	220	27,9	13,0	566	20	1240	326	39,2	19,3	566	21	910	11,9
112	220	35,7	17,8	774	27	1700	326	50,6	26,4	774	28	1250	14,3
121	220	41,6	20,6	896	31	1970	326	58,5	30,6	896	32	1450	17,7
212	220	47,4	24,1	1045	36	2290	326	66,7	35,7	1045	37	1690	20,1
221	220	55,0	28,2	1225	42	2690	326	77,5	41,8	1225	43	1980	23,0
122	220	72,2	36,5	1587	54	3490	325	100,2	54,0	1587	55	2580	33,5
141	220	82,7	42,7	1856	63	4080	326	115,7	63,2	1856	64	3010	36,5
222	220	95,7	49,6	2156	73	4740	325	133,5	73,4	2156	74	3500	43,0
241	220	110,6	57,2	2486	84	5460	325	154,1	84,6	2486	85	4040	50,1
142	220	143,9	75,2	3266	110	6000	325	200,7	111,2	3266	111	5300	64,9

Otras Velocidades disponibles bajo consulta a nuestra O.T. / Other speeds available on request

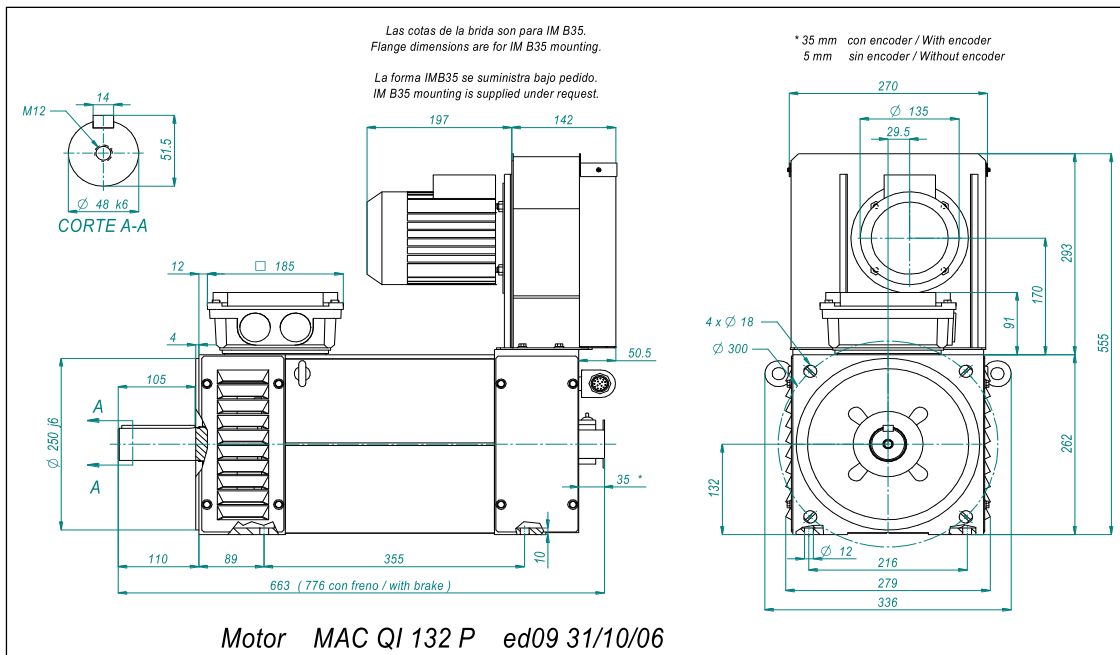

Datos Técnicos sujetos a modificaciones sin previo aviso / Technical Data are subject to changes without prior notice

Elabora: <b>David Gil</b> 15/05/2015 11:39:01	Revisa: <b>Jordi Trullen</b> 18/05/2015 18:10:12	Aprueba: <b>Jordi Trullen</b> 18/05/2015 18:10:21
---	--	---

<b>Ventilador / Fan</b>		Rodamientos <b>Delantero</b> 6310 ZZ C3 <b>Trasero</b> 6208 ZZ C3	
Tipo de Refrigeración <b>IC 06</b>		Bearings <b>Drive End</b> <b>Non Drive End</b>	
Cooling Mode			
Alimentación / Supply 400V 50Hz		Nº de polos 4 Momento de inercia <b>J = 0,114 Kg m<sup>2</sup></b> Peso Motor 175 Kg	
Potencia / Power 0,37 KW		Rotor Inertia	
Corriente / Current 1,11A		Protección IP 23 Construcción IM B3 / B35 Equilibrado grado A	
Velocidad / Speed 2800 rpm		Protection Degree	
Caudal / Air flow 900 m3/h		Mounting	
Presión / Pressure 680 Pa		Balancing degree	
Por favor, indicar en los pedidos la alimentación deseada para el ventilador / Please indicate the required fan supply voltage when placing your order		Nivel de ruido < 80 dB Velocidad máxima mecánica 6000 rpm	
		Noise Level	
		Max. Mechanical Speed	
		Aislamiento Clase F Protección Térmica PTC 140 °C Ambiente < 40 °C < 1000 m	
		Insulation Class	
		Thermal Protection	
		Ambient	
		Normas de referencia EN60034 Conmutación Variador 4 kHz ; du/dt TS60034-25 Type B	
		Reference Standards	
		Inverter Switching	
<b>Freno de Bloqueo (opcional)</b>		150 Nm 24 Vdc 3,5 A 85 W 12 Kg J = 0.0029 Kg m <sup>2</sup>	
<b>Holding Brake (optional)</b>			
Tensión de Base del Motor <b>Vb 400 V</b>		Tensión Máxima de Salida del Convertidor <b>Vc 400 V</b>	
Motor Base Voltage		Inverter max. Output Voltage	

Bobinado Winding	Servicio / Service S1						Servicio / Service S6 - 40%						Corriente en vacío No Load Current (A)
	Nm	A	KW	rpm	Hz	Velocidad a Pot.Cte Const. Power Speed. (rpm)	Nm	A	KW	rpm	Hz	Velocidad a Pot.Cte Const. Power Speed. (rpm)	
111	270	22,9	9,2	326	12	740	400	32,2	13,6	326	13	540	9,8
211	270	29,3	13,0	461	17	1060	400	41,1	19,3	461	17	780	12,8
112	270	37,5	17,7	625	22	1430	400	52,5	26,1	625	23	1050	16,5
121	270	43,1	21,1	745	26	1710	400	60,8	31,2	745	27	1260	17,9
212	270	49,3	24,4	865	30	1980	400	69,2	36,2	865	31	1460	21,2
221	270	57,2	28,7	1015	35	2330	400	80,4	42,5	1015	36	1720	24,4
122	270	74,0	38,0	1345	46	3090	400	103,9	56,3	1345	47	2280	31,9
141	270	85,4	43,9	1555	53	3570	400	119,7	65,1	1555	54	2640	37,2
222	270	99,2	50,8	1796	61	4130	399	138,0	75,0	1796	62	3050	45,5
241	270	113,9	59,2	2095	71	4810	400	159,5	87,6	2095	72	3550	50,0
142	270	148,0	77,9	2755	93	6000	400	207,3	115,2	2755	94	4660	64,9

Otras Velocidades disponibles bajo consulta a nuestra O.T. / Other speeds available on request

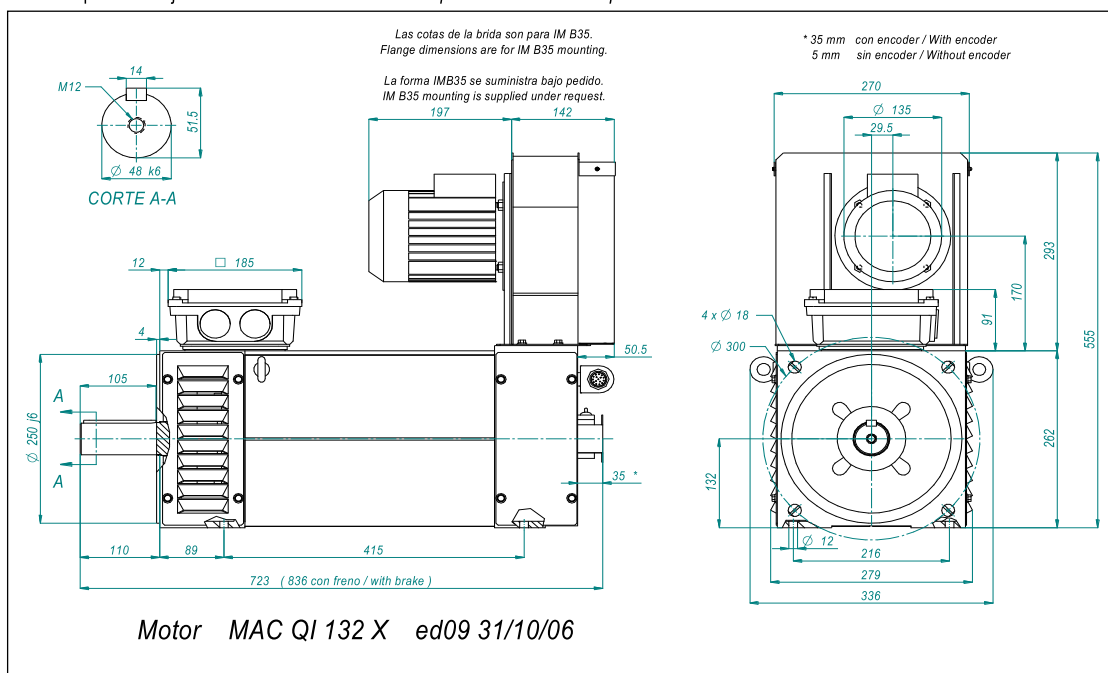

Datos técnicos sujetos a modificaciones sin previo aviso / Technical Data are subject to changes without prior notice

Elabora: <b>David Gil</b> 15/05/2015 11:41: 51	Revisa: <b>Jordi Trullen</b> 18/05/2015 18:10:41	Aprueba: <b>Jordi Trullen</b> 18/05/2015 18:10:49
--	---	---





### MOTOR MAC QI 160 S

- Hoja de Datos Técnicos -  
- Technical Datasheet -

Código DT-QH160S  
Edición 14  
Página 1/2  
Fecha 13/05/2016

Ventilador / Fan		Rodamientos		Delantero		Trasero	
Tipo de Refrigeración Cooling Mode	IC 06	Bearings		6312 ZZ C3		6310 ZZC3	
Alimentación / Supply	400V 50Hz	Nº de polos	4	Momento de inercia	J=0,239 Kg m <sup>2</sup>	Peso Motor	230 Kg
Potencia / Power	0,75 kW	Protección	IP 23	Construcción	IM B3 / B35	Equilibrado grado	A
Corriente / Current	1,9 A	Protección Degree		Mounting		Balancing degree	
Velocidad / Speed	2860 rpm	Nivel de ruido	< 80 dB	Velocidad máxima mecánica	5000 rpm		
Caudal / Air flow	1200 m <sup>3</sup> /h	Noise Level		Max. Mechanical Speed			
Presión / Pressure	800 Pa	Aislamiento Clase	F	Protección Térmica	PTC 140 °C	Ambiente	< 40 °C < 1000 m
Por favor, indicar en los pedidos la alimentación deseada para el ventilador / Please indicate the required fan supply voltage when placing your order		Insulation Class		Thermal Protection		Ambient	
		Normas de referencia	EN60034	Conmutación Variador	4 kHz; du/dt TS60034-25 Type B		
		Reference Standards		Inverter Switching			
<b>Freno de Bloqueo (opcional)</b> <b>Holding Brake (optional)</b>	300 Nm	24 Vdc	2.5 A	60 W	18 Kg	J = 0.0017 Kg m <sup>2</sup>	
Tensión de Base del Motor Motor Base Voltage	Vb	400 V			Tensión Máxima de Salida del Convertidor Inverter max. Output Voltage	Vc	400 V

Bobinado Winding	Servicio / Service S1						Servicio / Service S6 - 40%						Corriente en vacío No Load Current (A)
	Nm	A	KW	rpm	Hz	Velocidad a Pot.Cte Const. Power Speed. (rpm)	Nm	A	KW	rpm	Hz	Velocidad a Pot.Cte Const. Power Speed. (rpm)	
A41	340	35	18,2	510	18	1420	506	50	27,0	510	18	1040	12
B41	340	44	23,5	660	23	1840	506	63	35,0	660	23	1350	15
C41	340	52	28,9	811	28	2270	506	75	43,0	811	28	1670	18
D41	340	58	32,1	901	31	2520	506	83	47,7	901	31	1850	21
E41	340	69	38,5	1080	37	3020	505	99	57,1	1080	37	2220	26
F41	340	80	44,9	1260	43	3520	505	114	66,7	1260	43	2590	30
G41	340	94	53,4	1500	51	4200	505	135	79,3	1500	51	3090	35
H41	340	104	59,8	1680	57	4700	506	149	89,0	1680	57	3460	37
I41	340	115	66,2	1860	63	5000	506	165	98,5	1860	63	3830	41
J41	340	129	74,8	2100	71	5000	506	185	111,2	2100	71	4320	47
F42	340	139	80,1	2250	76	5000	506	198	119,1	2250	76	4620	50
G42	340	164	95,1	2670	90	5000	506	234	141,3	2670	90	5000	60
H42	340	180	105,7	2970	100	5000	506	259	157,3	2970	100	5000	63

Otras velocidades disponibles bajo consulta a nuestra O.T. / Other speeds available on request

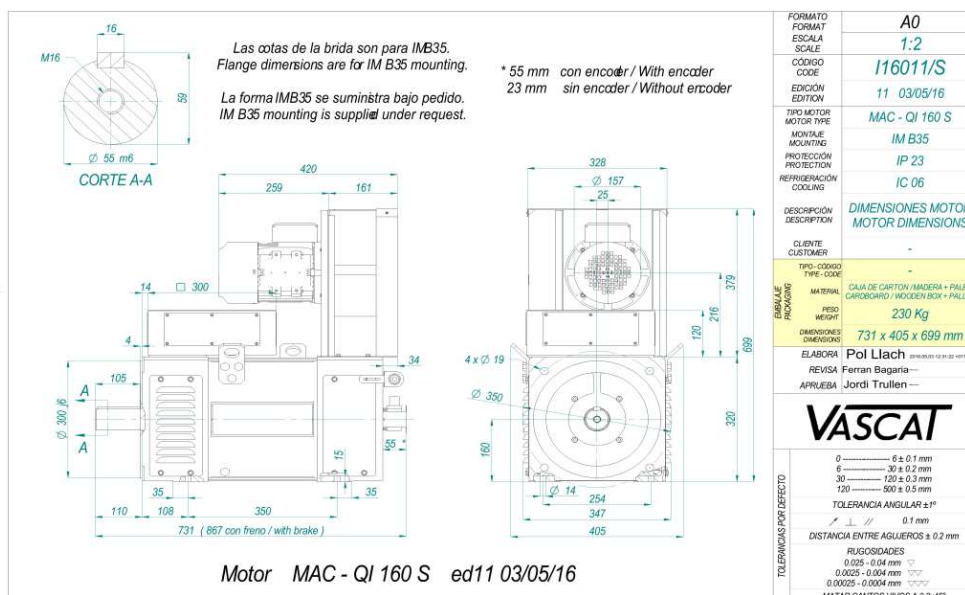

Datos Técnicos sujetos a modificaciones sin previo aviso / Technical data are subject to changes without prior notice

Elabora:  
**David Gil**

Revisa:  
**Jordi Trullen**

Aprueba:  
**Jordi Trullen**



# MOTOR MAC QI 160 M

- Hoja de Datos Técnicos -  
- Technical Datasheet -

Código DT-QI160M  
Edición 14  
Página 1/2  
Fecha 13/05/2016

Ventilador / Fan		Rodamientos		Delantero		Trasero	
Tipo de Refrigeración Cooling Mode		IC 06		Bearings		6312 ZZ C3	
Alimentación / Supply		400V 50Hz		Nº de polos		4	
Potencia / Power		0,75 kW		Momento de inercia		J=0,295 Kg m <sup>2</sup>	
Corriente / Current		1,9 A		Rotor Inertia		Motor Weight	
Velocidad / Speed		2860 rpm		Protección		IP 23	
Caudal / Air flow		1200 m <sup>3</sup> /h		Construcción		IM B3 / B35	
Presión / Pressure		800 Pa		Nivel de ruido		< 80 dB	
Por favor, indicar en los pedidos la alimentación deseada para el ventilador / Please indicate the required fan supply voltage when placing your order		Aislamiento Clase		Protección Térmica		Ambiente	
		F		PTC 140 °C		< 40 °C < 1000 m	
		Normas de referencia		Conmutación Variador		4 kHz; du/dt TS60034-25 Type B	
		EN60034		Inverter Switching			
<b>Freno de Bloqueo (opcional)</b> <b>Holding Brake (optional)</b>		300 Nm		24 Vdc		2.5 A	
		60 W		18 Kg		J = 0.0017 Kg m <sup>2</sup>	
Tensión de Base del Motor Motor Base Voltage		Vb		400 V		Tensión Máxima de Salida del Convertidor Inverter max. Output Voltage	
						Vc 400 V	

Bobinado Winding	Servicio / Service S1						Servicio / Service S6 - 40%						Corriente en vacío No Load Current (A)
	Nm	A	KW	rpm	Hz	Velocidad a Pot.Cte Const. Power Speed (rpm)	Nm	A	KW	rpm	Hz	Velocidad a Pot.Cte Const. Power Speed (rpm)	
A41	430	44	23,1	513	18	1430	639	63	34,3	513	18	1050	16
B41	430	56	29,9	663	23	1850	639	79	44,4	663	23	1360	21
C41	430	66	36,6	812	28	2270	640	94	54,4	812	28	1670	23
D41	430	75	42,0	932	32	2600	640	108	62,4	932	32	1910	26
E41	430	87	48,8	1083	37	3030	639	125	72,4	1083	37	2230	33
F41	430	95	54,1	1202	41	3360	640	137	80,5	1202	41	2470	34
G41	430	105	59,5	1322	45	3700	639	150	88,5	1322	45	2720	38
H41	430	116	66,3	1473	50	4120	639	166	98,6	1473	50	3030	43
I41	430	131	75,7	1682	57	4700	640	188	112,7	1682	57	3460	46
J41	430	149	86,5	1922	65	5000	640	214	128,7	1922	65	3950	53
F42	430	164	96,0	2132	72	5000	640	236	142,8	2132	72	4380	58
G42	430	181	105,5	2342	79	5000	640	259	156,8	2342	79	4810	65
H42	430	201	117,6	2612	88	5000	640	288	174,9	2612	88	5000	72
I42	430	226	132,5	2942	99	5000	640	324	197,0	2942	99	5000	81

Otras velocidades disponibles bajo consulta a nuestra O.T. / Other speeds available on request

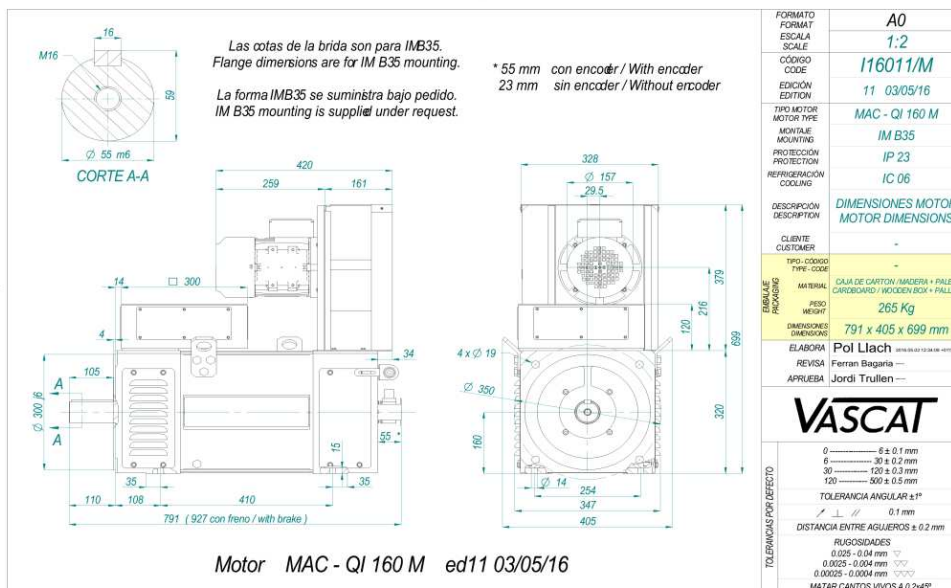

Datos Técnicos sujetos a modificaciones sin previo aviso / Technical data are subject to changes without prior notice

Elabora: <b>David Gil</b>	Revisa: <b>Jordi Trullen</b>	Aprueba: <b>Jordi Trullen</b>
------------------------------	---------------------------------	----------------------------------



# MOTOR MAC QI 160 L

- Hoja de Datos Técnicos -  
- Technical Datasheet -

Código DT-QI160L

Edición 14

Página 1/2

Fecha 13/05/2016

Ventilador / Fan		Rodamientos		Delantero		Trasero	
Tipo de Refrigeración Cooling Mode	IC 06	Bearings		6312 ZZ C3		6310 ZZC3	
Alimentación / Supply	400V 50Hz	Nº de polos	4	Momento de inercia	J=0,352 Kg m <sup>2</sup>	Peso Motor	301 Kg
Potencia / Power	0,75 kW	Protección	IP 23	Construcción	IM B3 / B35	Equilibrado grado	A
Corriente / Current	1,9 A	Protection Degree	IP 23	Mounting	IM B3 / B35	Balancing degree	A
Velocidad / Speed	2860 rpm	Nivel de ruido	< 80 dB	Velocidad máxima mecánica	5000 rpm		
Caudal / Air flow	1200m <sup>3</sup> /h	Noise Level	< 80 dB	Max. Mechanical Speed	5000 rpm		
Presión / Pressure	800 Pa	Aislamiento Clase	F	Protección Térmica	PTC 140 °C	Ambiente	< 40 °C < 1000 m
Insulation Class	F	Thermal Protection	PTC 140 °C	Ambient	< 40 °C < 1000 m		
Por favor, indicar en los pedidos la alimentación deseada para el ventilador / Please indicate the required fan supply voltage when placing your order		Normas de referencia	EN60034	Conmutación Variador	4 kHz; du/dt TS60034-25 Type B		
Reference Standards	EN60034	Inverter Switching	4 kHz; du/dt TS60034-25 Type B				
<b>Freno de Bloqueo (opcional)</b> <b>Holding Brake (optional)</b>	300 Nm	24 Vdc	2.5 A	60 W	18 Kg	J = 0.0017 Kg m <sup>2</sup>	
Tensión de Base del Motor Motor Base Voltage	Vb	400 V			Tensión Máxima de Salida del Convertidor Inverter max. Output Voltage	Vc	400 V

Bobinado Winding	Servicio / Service S1						Servicio / Service S6 - 40%						Corriente en vacío No Load Current (A)
	Nm	A	KW	rpm	Hz	Velocidad a Pot. Cte Const. Power Speed. (rpm)	Nm	A	KW	rpm	Hz	Velocidad a Pot. Cte Const. Power Speed. (rpm)	
A41	510	50	25,8	484	17	1400	757	71	38,4	484	17	1030	20
B41	510	58	30,7	574	20	1660	757	83	45,5	574	20	1220	23
C41	510	70	37,1	695	24	2010	756	98	55,0	695	24	1480	29
D41	510	87	48,3	904	31	2620	758	124	71,7	904	31	1930	32
E41	510	104	57,9	1084	37	3140	758	147	85,9	1084	37	2310	40
F41	510	115	64,3	1204	41	3490	757	163	95,4	1204	41	2570	46
G41	510	130	72,4	1355	46	3920	756	183	107,3	1355	46	2890	53
H41	510	148	83,5	1564	53	4530	757	209	123,9	1564	53	3340	59
I41	510	172	97,9	1834	62	5000	757	244	145,3	1834	62	3910	69
F42	510	198	114,0	2134	72	5000	757	282	169,1	2134	72	4540	78
G42	500	221	124,4	2375	80	5000	741	310	184,1	2375	80	5000	95
H42	490	248	140,4	2736	92	5000	726	348	207,9	2736	92	5000	106
I42	480	285	160,1	3186	107	5000	710	398	236,8	3186	107	5000	127

Otras velocidades disponibles bajo consulta a nuestra O.T. / Other speeds available on request

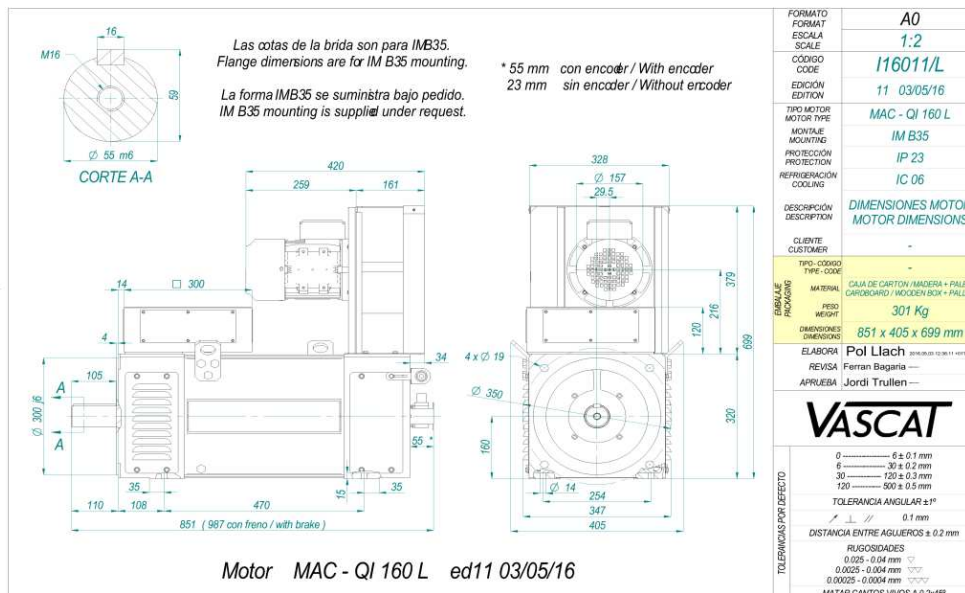

Datos Técnicos sujetos a modificaciones sin previo aviso / Technical data are subject to changes without prior notice

Elabora: <b>David Gil</b>	Revisa: <b>Jordi Trullen</b>	Aprueba: <b>Jordi Trullen</b>
------------------------------	---------------------------------	----------------------------------



### MOTOR MAC QI 160 P

- Hoja de Datos Técnicos -  
- Technical Datasheet -

Código DT-QI160P

Edición 14

Página 1/2

Fecha 13/05/2016

Ventilador / Fan		Rodamientos		Delantero		Trasero	
Tipo de Refrigeración Cooling Mode	IC 06	Bearings		Drive End		Non Drive End	
Alimentación / Supply	400V 50Hz	Nº de polos	4	Momento de inercia	J=0,389 Kg m <sup>2</sup>	Peso Motor	325 Kg
Potencia / Power	0,75 kW	Protección	IP 23	Construcción	IM B3 / B35	Equilibrado grado	A
Corriente / Current	1,9 A	Protection Degree		Mounting		Balancing degree	
Velocidad / Speed	2860 rpm	Nivel de ruido	< 80 dB	Velocidad máxima mecánica	5000 rpm		
Caudal / Air flow	1200 m <sup>3</sup> /h	Noise Level		Max. Mechanical Speed			
Presión / Pressure	800 Pa	Aislamiento Clase	F	Protección Térmica	PTC 140 °C	Ambiente	< 40 °C < 1000 m
Por favor, indicar en los pedidos la alimentación deseada para el ventilador / Please indicate the required fan supply voltage when placing your order		Insulation Class		Thermal Protection		Ambient	
		Normas de referencia	EN60034	Conmutación Variador	4 kHz; du/dt TS60034-25 Type B		
		Reference Standards		Inverter Switching			
<b>Freno de Bloqueo (opcional)</b> <b>Holding Brake (optional)</b>	300 Nm	24 Vdc	2.5 A	60 W	18 Kg	J = 0.0017 Kg m <sup>2</sup>	
Tensión de Base del Motor Motor Base Voltage	Vb	400 V			Tensión Máxima de Salida del Convertidor Inverter max. Output Voltage	Vc	400 V

Bobinado Winding	Servicio / Service S1						Servicio / Service S6 - 40%						Corriente en vacío No Load Current (A)
	Nm	A	KW	rpm	Hz	Velocidad a Pot. Cte Const. Power Speed. (rpm)	Nm	A	KW	rpm	Hz	Velocidad a Pot. Cte Const. Power Speed. (rpm)	
A41	570	57	30,6	513	18	1480	848	82	45,5	513	18	1090	20
B41	570	75	41,4	693	24	2000	848	108	61,5	693	24	1470	27
C41	570	87	48,6	814	28	2360	848	125	72,2	814	28	1730	31
D41	570	105	59,3	993	34	2870	848	150	88,1	993	34	2110	38
E41	570	116	66,4	1113	38	3220	848	167	98,8	1113	38	2370	41
F41	570	131	75,4	1263	43	3660	848	188	112,2	1263	43	2690	46
G41	570	149	86,1	1443	49	4180	848	214	128,1	1443	49	3080	54
H41	570	174	100,5	1684	57	4880	847	249	149,4	1684	57	3590	65
I41	570	209	121,9	2043	69	5000	848	300	181,3	2043	69	4350	75
F42	550	219	128,1	2224	75	5000	818	314	190,4	2224	75	4730	80
G42	530	243	141,8	2555	86	5000	788	347	210,6	2555	86	5000	92
H42	510	275	158,9	2976	100	5000	757	389	235,7	2976	100	5000	110

Otras velocidades disponibles bajo consulta a nuestra O.T. / Other speeds available on request

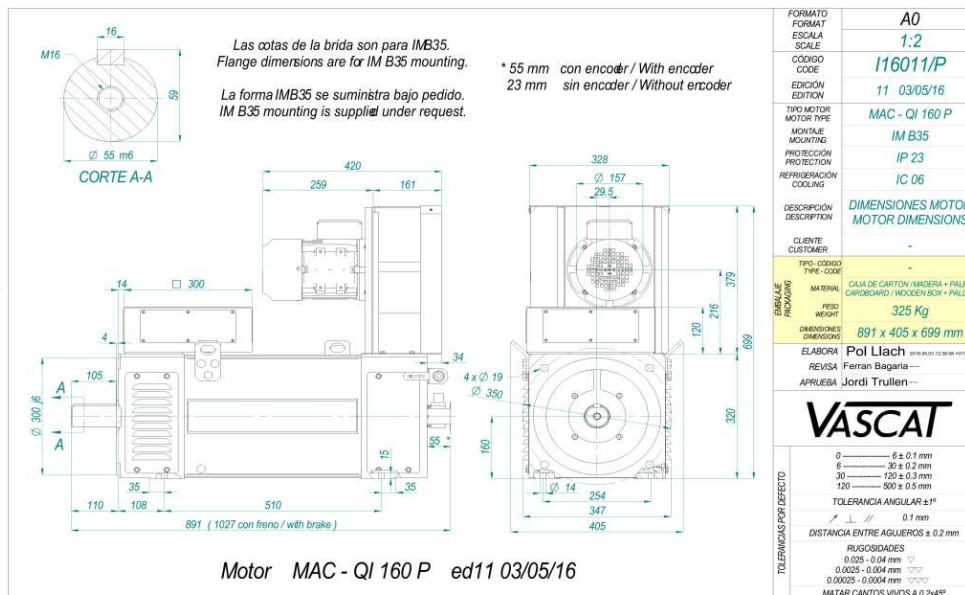

Datos Técnicos sujetos a modificaciones sin previo aviso / Technical data are subject to changes without prior notice

Elabora:  
**David Gil**

Revisa:  
**Jordi Trullen**

Aprueba:  
**Jordi Trullen**



# MOTOR MAC QI 160 X

- Hoja de Datos Técnicos -  
- Technical Datasheet -

Código DT-QI160X  
Edición 04  
Página 1/2  
Fecha 13/05/2016

Ventilador / Fan		Rodamientos		Delantero		Trasero	
Tipo de Refrigeración Cooling Mode	IC 06	Bearings		6312 ZZ C3		6310 ZZC3	
Alimentación / Supply	400V 50Hz	Nº de polos	4	Momento de inercia	J=0,432 Kg m <sup>2</sup>	Peso Motor	
Potencia / Power	0,75 kW	Rotor Inertia				Motor Weight	
Corriente / Current	1,9 A	Protección	IP 23	Construcción		Equilibrado grado	
Velocidad / Speed	2860 rpm	Protection Degree		IM B3 / B35		Balancing degree	
Caudal / Air flow	1200 m <sup>3</sup> /h	Noise Level		Velocidad máxima mecánica		5000 rpm	
Presión / Pressure	800 Pa	Level de ruido		Max. Mechanical Speed			
Por favor, indicar en los pedidos la alimentación deseada para el ventilador / Please indicate the required fan supply voltage when placing your order		Aislamiento Clase		Protección Térmica		Ambiente	
		Insulation Class		Thermal Protection		Ambient	
		Normas de referencia		Conmutación Variador		4 kHz; du/dt TS60034-25 Type B	
		Reference Standards		Inverter Switching			
<b>Freno de Bloqueo (opcional)</b>		300 Nm		24 Vdc		2.5 A	
<b>Holding Brake (optional)</b>				60 W		18 Kg	
						J = 0.0017 Kg m <sup>2</sup>	
Tensión de Base del Motor		Vb		400 V		Tensión Máxima de Salida del Convertidor	
Motor Base Voltage						Vc	
						400 V	
						Inverter max. Output Voltage	

Bobinado Winding	Servicio / Service S1						Servicio / Service S6 - 40%						Corriente en vacío No Load Current (A)
	Nm	A	KW	rpm	Hz	Velocidad a Pot. Const. Power Speed. (rpm)	Nm	A	KW	rpm	Hz	Velocidad a Pot. Const. Power Speed. (rpm)	
A41	640	69	34,5	515	18	1490	946	97	51,0	515	18	1100	32
B41	640	79	40,5	604	21	1750	947	110	59,9	604	21	1290	35
C41	640	91	48,5	723	25	2090	949	129	71,8	723	25	1540	38
D41	640	109	58,6	874	30	2530	948	153	86,7	874	30	1870	47
E41	640	136	74,6	1113	38	3220	951	194	110,8	1113	38	2370	52
F41	640	156	84,7	1264	43	3660	947	217	125,2	1264	43	2700	70
G41	640	181	100,7	1503	51	4350	948	255	149,2	1503	51	3210	77
H41	640	217	120,9	1804	61	5000	947	304	178,9	1804	61	3850	95
E42	620	229	126,9	1955	66	5000	917	320	187,6	1955	66	4170	104
F42	600	255	141,7	2255	76	5000	887	355	209,3	2255	76	4800	116
G42	570	285	157,9	2646	89	5000	841	395	233,0	2646	89	5000	134
H42	520	318	175,2	3218	108	5000	766	438	258,1	3218	108	5000	156

Otras velocidades disponibles bajo consulta a nuestra O.T. / Other speeds available on request

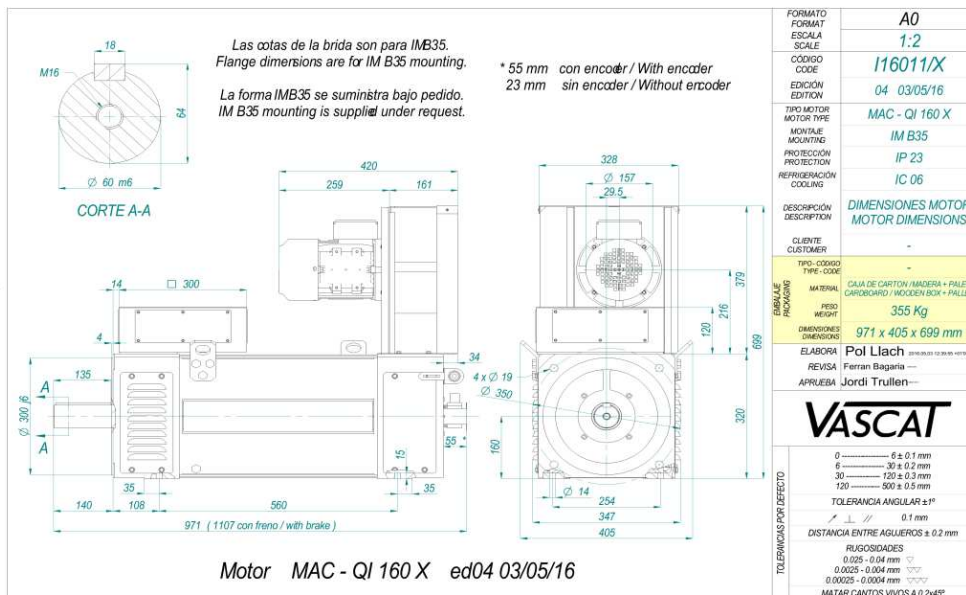

Datos Técnicos sujetos a modificaciones sin previo aviso / Technical data are subject to changes without prior notice

Elabora:  
**David Gil**

Revisa:  
**Jordi Trullen**

Aprueba:  
**Jordi Trullen**



## MOTOR MAC QI 200 S

- Hoja de Datos Técnicos -  
- Technical Datasheet -

Código DT-QI200S  
Edición 09  
Página 1/2  
Fecha 30/04/2015

Ventilador / Fan		Rodamientos		Delantero		Trasero	
Tipo de Refrigeración		Bearings		Drive End		Non Drive End	
Cooling Mode	IC 06	6316 ZZ C3		6312 ZZC3			
Alimentación / Supply	400V 50Hz	Nº de polos	6	Momento de inercia	J=0,597 Kg m <sup>2</sup>	Peso Motor	380 Kg
Potencia / Power	1,50 kW	No of poles		Rotor Inertia		Motor Weight	
Corriente / Current	2,9 A	Protección	IP 23	Construcción	IM B3 / B35	Equilibrado grado	A
Velocidad / Speed	2860 rpm	Protection Degree		Mounting		Balancing degree	
Caudal / Air flow	2400 m <sup>3</sup> /h	Nivel de ruido	< 80 dB	Velocidad máxima mecánica		4000 rpm	
Presión / Pressure	1000 Pa	Noise Level		Max. Mechanical Speed			
Por favor, indicar en los pedidos la alimentación deseada para el ventilador / Please indicate the required fan supply voltage when placing your order		Aislamiento Clase	F	Protección Térmica	PTC 140 °C	Ambiente	< 40 °C < 1000 m
		Insulation Class		Thermal Protection		Ambient	
		Normas de referencia	EN60034	Comutación Variador	4 kHz; du/dt TS60034-25 Type B		
		Reference Standards		Inverter Switching			
<b>Freno de Bloqueo (opcional)</b>		300 Nm	24 Vdc	2.5 A	60 W	18 Kg	J = 0.0017 Kg m <sup>2</sup>
<b>Holding Brake (optional)</b>							
Tensión de Base del Motor		Vb	400 V	Tensión Máxima de Salida del Convertidor		Vc	400 V
Motor Base Voltage				Inverter max. Output Voltage			

Bobinado Winding	Servicio / Service S1						Servicio / Service S6 - 40%						Corriente en vacío No Load Current (A)
	Nm	A	KW	rpm	Hz	Velocidad a Pot. Cte Const. Power Speed. (rpm)	Nm	A	KW	rpm	Hz	Velocidad a Pot. Cte Const. Power Speed. (rpm)	
A61	650	63	32,0	470	25	840	960	90	47,2	470	26	620	24
B61	650	82	42,9	630	33	1130	960	117	63,3	630	34	830	31
C61	650	98	52,4	770	40	1380	960	141	77,4	770	41	1020	36
D61	650	129	68,7	1010	52	1810	960	183	101,5	1010	53	1340	51
E61	650	163	89,1	1310	67	2350	960	233	131,6	1310	68	1740	62
F61	650	188	102,7	1510	77	2710	960	268	151,7	1510	78	2000	73
G61	650	223	123,1	1810	92	3250	960	318	181,9	1810	93	2400	83
H61	650	245	135,4	1990	101	3580	960	349	200,0	1990	102	2650	93
I 61	610	258	141,1	2210	112	3970	900	365	208,2	2210	113	2940	106

Otras velocidades disponibles bajo consulta a nuestra O.T. / Other speeds available on request

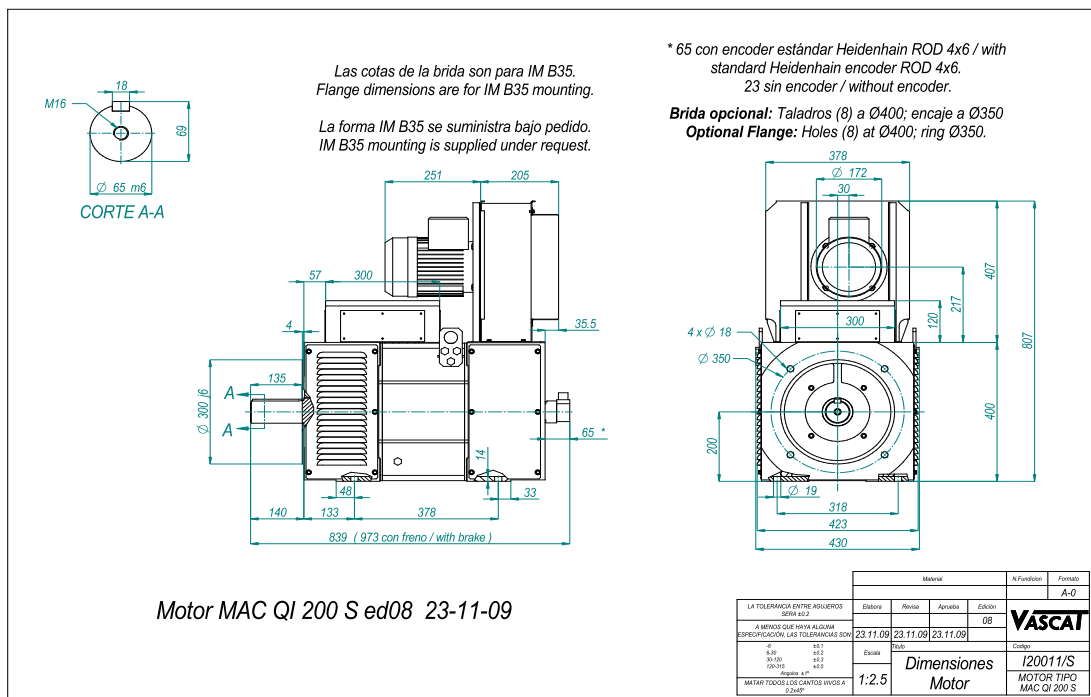

Datos Técnicos sujetos a modificaciones sin previo aviso / Technical data are subject to changes without prior notice

Elabora:	Revisa:	Aprueba:
David Gil	Jordi Trullen	Jordi Trullen
19/05/2015 9:11:57	19/05/2015 12:48:42	19/05/2015 12:48:51



### MOTOR MAC QI 200 M

- Hoja de Datos Técnicos -  
- Technical Datasheet -

Código DT-QI200M  
Edición 09  
Página 1/2  
Fecha 30/04/2015

Ventilador / Fan		Rodamientos		Delantero		Trasero	
Tipo de Refrigeración Cooling Mode	IC 06	Bearings	6316 ZZ C3	Drive End	6312 ZCC3	Non Drive End	
Alimentación / Supply	400V 50Hz	Nº de polos	6	Momento de inercia	J=0,805 Kg m <sup>2</sup>	Peso Motor	455 Kg
Potencia / Power	1,50 kW	Protección	IP 23	Construcción	IM B3 / B35	Equilibrado grado	A
Corriente / Current	2,9 A	Protection Degree		Mounting		Balancing degree	
Velocidad / Speed	2860 rpm	Nivel de ruido	< 80 dB	Velocidad máxima mecánica	4000 rpm		
Caudal / Air flow	2400 m <sup>3</sup> /h	Noise Level		Max. Mechanical Speed			
Presión / Pressure	1000 Pa	Aislamiento Clase	F	Protección Térmica	PTC 140 °C	Ambiente	< 40 °C < 1000 m
Insulation Class		Thermal Protection		Ambient			
Por favor, indicar en los pedidos la alimentación deseada para el ventilador / Please indicate the required fan supply voltage when placing your order		Normas de referencia	EN60034	Conmutación Variador	4 kHz; du/dt TS60034-25 Type B		
Reference Standards		Inverter Switching					
<b>Freno de Bloqueo (opcional)</b> <b>Holding Brake (optional)</b>	300 Nm	24 Vdc	2.5 A	60 W	18 Kg	J = 0.0017 Kg m <sup>2</sup>	
Tensión de Base del Motor Motor Base Voltage	Vb	400 V		Tensión Máxima de Salida del Convertidor Inverter max. Output Voltage	Vc	400 V	

Bobinado Winding	Servicio / Service S1						Servicio / Service S6 - 40%						Corriente en vacío No Load Current (A)
	Nm	A	KW	rpm	Hz	Velocidad a Pot.Cte Const. Power Speed. (rpm)	Nm	A	KW	rpm	Hz	Velocidad a Pot.Cte Const. Power Speed. (rpm)	
A61	850	82	42	470	25	940	1260	117	62	470	26	690	32
B61	850	98	51	570	30	1140	1260	139	75	570	31	840	40
C61	850	124	65	730	38	1460	1260	175	96	730	39	1070	51
D61	850	157	83	930	48	1860	1250	220	122	930	49	1380	67
E61	850	196	106	1190	61	2380	1260	277	157	1190	62	1750	79
F61	850	235	127	1430	73	2860	1260	331	189	1430	74	2110	97
G61	850	261	141	1590	81	3180	1250	367	208	1590	82	2360	109
H61	820	285	155	1810	92	3620	1210	401	229	1810	93	2680	119
I 61	790	316	171	2070	105	4000	1160	443	251	2070	106	3070	139

Otras velocidades disponibles bajo consulta a nuestra O.T. / Other speeds available on request

**CORTE A-A**

Las cotas de la brida son para IM B35.  
Flange dimensions are for IM B35 mounting.

La forma IM B35 se suministra bajo pedido.  
IM B35 mounting is supplied under request.

\* 65 con encoder estándar Heidenhain ROD 4x6 / with standard Heidenhain encoder ROD 4x6.  
23 sin encoder / without encoder.

**Brida opcional:** Taladros (8) a Ø400; encaje a Ø350  
**Optional Flange:** Holes (8) at Ø400; ring Ø350.

**Motor MAC QI 200 M ed08 23-11-09.**

Material		Nº Función	Formato
LA TOLERANCIA ENTRE ANILLOS SERÁ H7/g6		Embrós	A-0
A MENOS QUE HAYA ALGUNA ESPECIFICACIÓN LAS TOLERANCIAS SON:		Revisa	Edición
±	0.1	23.11.09	23.11.09
H7	H7	<b>VASCAT</b> Dimensiones <b>120011/M</b> MOTOR TIPO <b>MAC QI 200 M</b>	
H8	H8		
H9	H9		
H10	H10		
MANTEN TODOS LOS CARACTERÍSTICAS ENVIOS A 0.25MP		1:2.5	

Datos Técnicos sujetos a modificaciones sin previo aviso / Technical data are subject to changes without prior notice

Elabora: <b>David Gil</b> 19/05/2015 10:17:53	Revisa: <b>Jordi Trullen</b> 19/05/2015 12:49:21	Aprueba: <b>Jordi Trullen</b> 19/05/2015 12:49:31
--	---	--



# MOTOR MAC QI 200 L

- Hoja de Datos Técnicos -  
- Technical Datasheet -

Código DT-QI200L  
Edición 09  
Página 1/2  
Fecha 30/04/2015

Ventilador / Fan		Rodamientos		Delantero		Trasero	
Tipo de Refrigeración Cooling Mode	IC 06	Bearings		Drive End 6316 ZZ C3		Non Drive End 6312 ZCC3	
Alimentación / Supply	400V 50Hz	Nº de polos	6	Momento de inercia Rotor Inertia	J=1,064 Kg m <sup>2</sup>	Peso Motor Motor Weight	550 Kg
Potencia / Power	1,50 kW	Protección Protection Degree	IP 23	Construcción Mounting	IM B3 / B35	Equilibrado grado Balancing degree	A
Corriente / Current	2,9 A	Nivel de ruido Noise Level	< 80 dB	Velocidad máxima mecánica Max. Mechanical Speed	4000 rpm		
Velocidad / Speed	2860 rpm	Aislamiento Clase Insulation Class	F	Protección Térmica Thermal Protection	PTC 140 °C	Ambiente Ambient	< 40 °C < 1000 m
Caudal / Air flow	2400 m <sup>3</sup> /h	Normas de referencia Reference Standards	EN60034	Comutación Variador Inverter Switching	4 kHz; du/dt TS60034-25 Type B		
Presión / Pressure	1000 Pa	Por favor, indicar en los pedidos la alimentación deseada para el ventilador / Please indicate the required fan supply voltage when placing your order					
<b>Freno de Bloqueo (opcional) Holding Brake (optional)</b>		300 Nm	24 Vdc	2.5 A	60 W	18 Kg	J = 0.0017 Kg m <sup>2</sup>
Tensión de Base del Motor Motor Base Voltage		Vb	400 V		Tensión Máxima de Salida del Convertidor Inverter max. Output Voltage		Vc 400 V

Bobinado Winding	Servicio / Service S1						Servicio / Service S6 - 40%						Corriente en vacío No Load Current (A)
	Nm	A	KW	rpm	Hz	Velocidad a Pot.Cte Const. Power Speed. (rpm)	Nm	A	KW	rpm	Hz	Velocidad a Pot.Cte Const. Power Speed. (rpm)	
A61	1100	105	54	470	25	980	1630	150	80	470	26	720	42
B61	1100	128	66	570	30	1190	1620	180	97	570	31	880	55
C61	1100	144	75	650	34	1360	1630	202	111	650	35	1000	60
D61	1100	176	93	810	42	1700	1620	248	137	810	43	1260	75
E61	1100	208	112	970	50	2030	1630	294	165	970	51	1500	87
F61	1100	255	137	1190	61	2490	1620	358	202	1190	62	1840	108
G61	1100	286	155	1350	69	2830	1630	404	230	1350	70	2090	120
H61	1100	327	178	1550	79	3250	1630	461	264	1550	80	2400	137
I 61	1050	368	199	1810	92	3800	1550	515	294	1810	93	2810	162

Otras velocidades disponibles bajo consulta a nuestra O.T. / Other speeds available on request

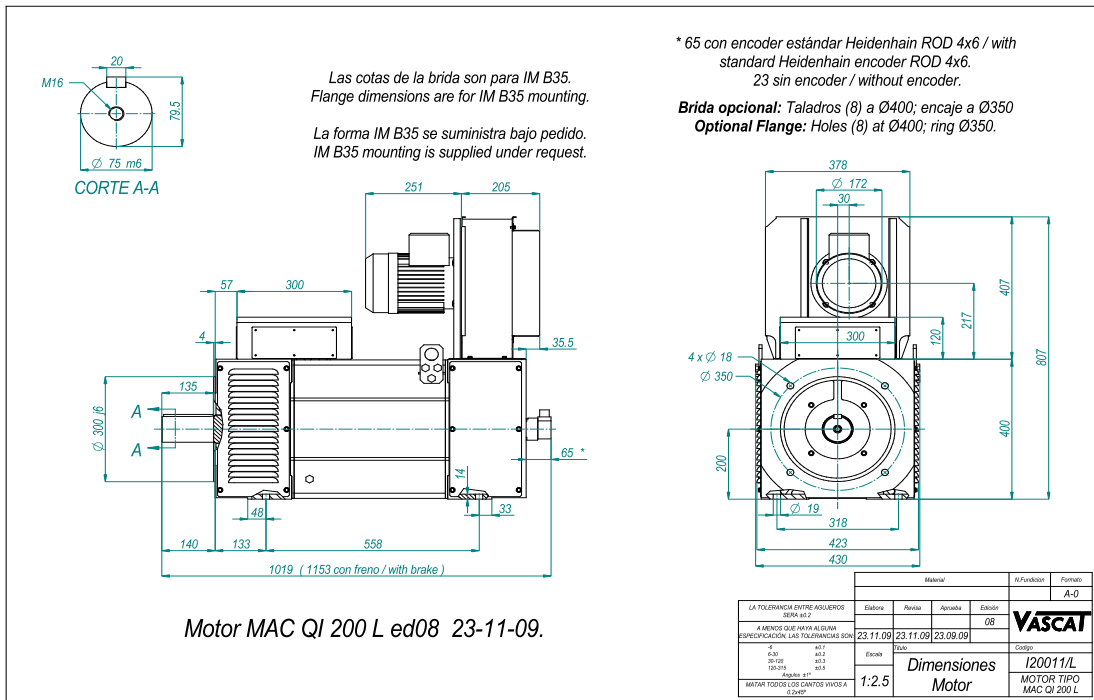

Datos Técnicos sujetos a modificaciones sin previo aviso / Technical data are subject to changes without prior notice

Elabora: <b>David Gil</b> 19/05/2015 10:22:41	Revisa: <b>Jordi Trullen</b> 19/05/2015 12:49:50	Aproba: <b>Jordi Trullen</b> 19/05/2015 12:50:00
---	--	--





### MOTOR MAC QI 200 P

- Hoja de Datos Técnicos -  
- Technical Datasheet -

Codigo DT-QI200P  
Edición 10  
Página 1/2  
Fecha 30/04/2015

Ventilador / Fan		Rodamientos		Delantero		Trasero	
Tipo de Refrigeración		Bearings		Drive End		Non Drive End	
Cooling Mode	IC 06			6316 ZZ C3		6312 ZZC3	
Alimentación / Supply	400V 50Hz	Nº de polos	6	Momento de inercia	J=1,324 Kg m <sup>2</sup>	Peso Motor	640 Kg
Potencia / Power	1,50 kW	No of poles		Rotor Inertia		Motor Weight	
Corriente / Current	2,9 A	Protección	IP 23	Construcción	IM B3 / B35	Equilibrado grado A	
Velocidad / Speed	2860 rpm	Protection Degree		Mounting		Balancing degree	
Caudal / Air flow	2400 m <sup>3</sup> /h	Nivel de ruido	< 80 dB	Velocidad máxima mecánica		4000 rpm	
Presión / Pressure	1000 Pa	Noise Level		Max. Mechanical Speed			
Por favor, indicar en los pedidos la alimentación deseada para el ventilador / Please indicate the required fan supply voltage when placing your order		Aislamiento Clase	F	Protección Térmica	PTC 140 °C	Ambiente < 40 °C < 1000 m	
		Insulation Class		Thermal Protection		Ambient	
		Normas de referencia	EN60034	Comutación Variador	4 kHz; du/dt TS60034-25 Type B		
		Reference Standards		Inverter Switching			
<b>Freno de Bloqueo (opcional)</b>		300 Nm	24 Vdc	2.5 A	60 W	18 Kg	J = 0.0017 Kg m <sup>2</sup>
<b>Holding Brake (optional)</b>							
Tensión de Base del Motor		Vb		400 V		Tensión Máxima de Salida del Convertidor	
Motor Base Voltage						Vc	
						400 V	
						Inverter max. Output Voltage	

Bobinado Winding	Servicio / Service S1						Servicio / Service S6 - 40%						Corriente en vacío No Load Current (A)
	Nm	A	KW	rpm	Hz	Velocidad a Pot.Cte Const. Power Speed. (rpm)	Nm	A	KW	rpm	Hz	Velocidad a Pot.Cte Const. Power Speed. (rpm)	
A61	1350	129	64	450	24	990	1990	179	94	450	25	730	60
B61	1350	155	78	550	29	1210	1990	215	115	550	30	890	72
C61	1350	180	92	650	34	1430	1990	250	135	650	35	1060	82
D61	1350	210	109	770	40	1690	1990	293	160	770	41	1250	97
E61	1350	257	134	950	49	2090	1990	357	198	950	50	1550	119
F61	1350	289	151	1070	55	2350	1990	401	223	1070	56	1740	135
G61	1350	330	174	1230	63	2700	1990	458	256	1230	64	2000	154
H61	1350	386	202	1430	73	3140	1990	532	298	1430	74	2320	186
E62	1280	430	228	1700	86	3740	1880	591	335	1700	86	2780	209
F62	1200	461	241	1920	97	4000	1760	629	354	1920	97	3110	236

Otras Velocidades disponibles bajo consulta a nuestra O.T. / Other speeds available under request

**CORTE A-A**

Las cotas de la brida son para IM B35.  
Flange dimensions are for IM B35 mounting.

La forma IM B35 se suministra bajo pedido.  
IM B35 mounting is supplied under request.

\* 65 con encoder estándar Heidenhain ROD 4x6 / with standard Heidenhain encoder ROD 4x6.  
23 sin encoder / without encoder.

**Brida opcional:** Taladros (8) a Ø400; encaje a Ø350  
**Optional Flange:** Holes (8) at Ø400; ring Ø350.

**Motor MAC QI 200 P ed08 23-11-09.**

Material		Nº Funciones		Zonas	
Elabore	Revisa	Aprobado	Edición	A-D	
23.11.09	23.11.09	23.11.09	23.11.09	08	
<b>VASCAT</b>					
Dimensiones Motor					
1:2.5					
I20011/P					
MOTOR TIPO MAC QI 200 P					

Datos Técnicos sujetos a modificaciones sin previo aviso / Technical data are subject to changes without prior notice

Elabora:	Revisa:	Aprobado:	
David Gil	Jordi Trullen	Jordi Trullen	
19/05/2015 10:26:31	19/05/2015 12:50:15	19/05/2015 12:50:25	



# MOTOR MAC QI 200 X

- Hoja de Datos Técnicos -  
- Technical Datasheet -

Codigo DT-QI200X  
Edición 04  
Página 1/2  
Fecha 30/04/2015

<b>Ventilador / Fan</b>		Rodamientos		Delantero		Trasero	
Tipo de Refrigeración		Bearings		Drive End		Non Drive End	
Cooling Mode		Nº de polos		Momento de inercia		Peso Motor	
IC 06		6		J=1,676 Kg m <sup>2</sup>		760 Kg	
Alimentación / Supply		Protección		Construcción		Equilibrado grado	
400V 50Hz		IP 23		IM B3 / B35		A	
Potencia / Power		Protection Degree		Mounting		Balancing degree	
1,50 kW		Nivel de ruido		Velocidad máxima mecánica		4000 rpm	
Corriente / Current		Noise Level		Max. Mechanical Speed			
2,9 A		< 80 dB					
Velocidad / Speed		Aislamiento Clase		Protección Térmica		Ambiente	
2860 rpm		F		PTC 140 °C		< 40 °C < 1000 m	
Caudal / Air flow		Insulation Class		Thermal Protection		Ambient	
2400 m <sup>3</sup> /h		Normas de referencia		Conmutación Variador		4 kHz; du/dt TS60034-25 Type B	
Presión / Pressure		Reference Standards		Inverter Switching			
1000 Pa		EN60034					
Por favor, indicar en los pedidos la alimentación deseada para el ventilador / Please indicate the required fan supply voltage when placing your order							
<b>Freno de Bloqueo (opcional)</b>		300 Nm		24 Vdc		2.5 A	
<b>Holding Brake (optional)</b>				60 W		18 Kg	
						J = 0.0017 Kg m <sup>2</sup>	
Tensión de Base del Motor		Vb		Tensión Máxima de Salida del Convertidor		Vc	
Motor Base Voltage		400 V		Inverter max. Output Voltage		400 V	

Bobinado Winding	Servicio / Service S1						Servicio / Service S6 - 40%						Corriente en vacío No Load Current (A)
	Nm	A	KW	rpm	Hz	Velocidad a Pot.Cte Const. Power Speed. (rpm)	Nm	A	KW	rpm	Hz	Velocidad a Pot.Cte Const. Power Speed. (rpm)	
A61	1600	126	63	379	20	850	2360	176	94	379	20	630	54
B61	1600	150	77	460	24	1030	2360	210	114	460	24	760	67
C61	1600	173	90	539	28	1210	2360	243	133	539	28	890	75
D61	1600	204	107	639	33	1430	2360	286	158	639	33	1060	91
E61	1600	250	134	799	41	1790	2370	351	198	799	42	1320	106
F61	1600	281	151	899	46	2020	2360	394	222	899	46	1490	122
G61	1600	321	174	1039	53	2330	2370	451	258	1039	54	1720	136
H61	1600	374	201	1200	61	2700	2360	522	296	1200	61	2000	167
E62	1600	431	234	1399	71	3140	2360	603	346	1399	71	2320	192
F62	1525	467	252	1580	80	3550	2250	649	372	1580	80	2630	217
G62	1450	514	276	1821	92	4000	2130	710	406	1821	92	3030	245

Otras Velocidades disponibles bajo consulta a nuestra O.T. / Other speeds available under request

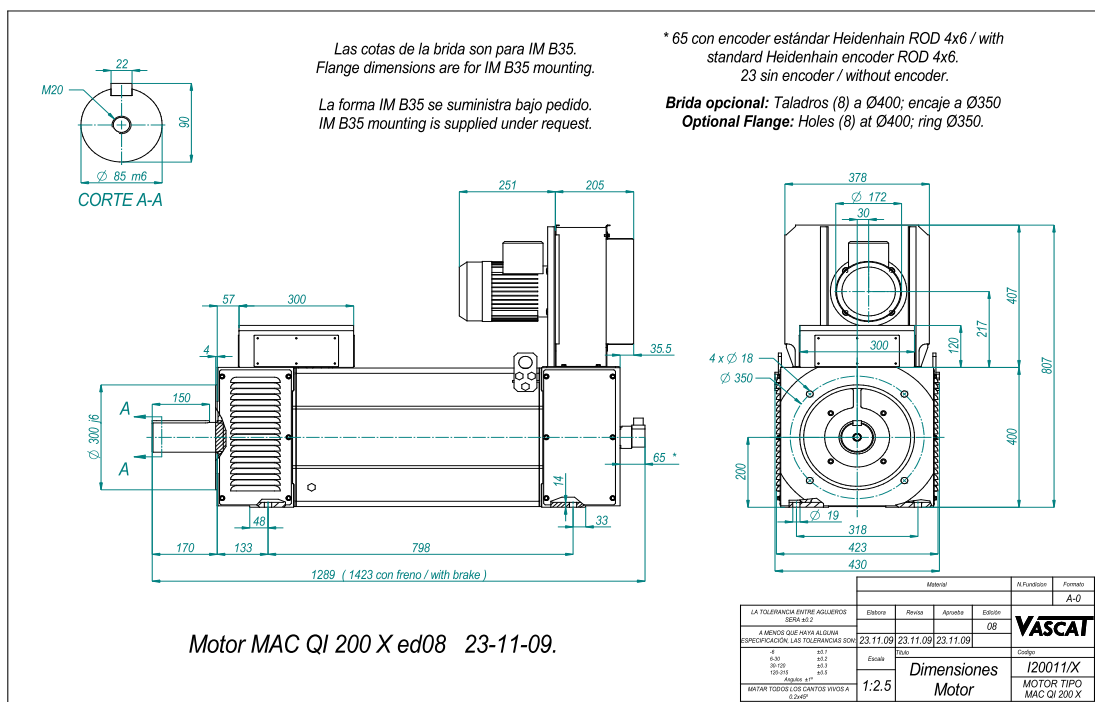

Datos Técnicos sujetos a modificaciones sin previo aviso / Technical data are subject to changes without prior notice

Elabora: David Gil	Revisa: Jordi Trullen	Aprueba: Jordi Trullen
19/05/2015 10:44:06	19/05/2015 12:50:46	19/05/2015 12:50:57



### MOTOR MAC QI 250 S

- Hoja de Datos Técnicos -  
- Technical Datasheet -

Código DT-QI250S  
Edición 09  
Página 1/2  
Fecha 25/03/2015

Ventilador / Fan		Rodamientos				Delantero		Trasero	
Tipo de Refrigeración Cooling Mode		IC 06		Bearings		6224.C3		8316.C3.J20AA	
Alimentación / Supply		400V 50Hz		Nº de polos		6		Momento de inercia	
Potencia / Power		4 KW		Rotor Inertia		J=1,773 Kg m <sup>2</sup>		Peso Motor	
Corriente / Current		7,6 A		Protección		IP 23		Construcción	
Velocidad / Speed		2885 rpm		Protection Degree		IM B3 / B35		Equilibrado grado	
Caudal / Air flow		3210 m <sup>3</sup> /h		Noise Level		< 85 dB		Max. Mechanical Speed	
Presión / Pressure		2450 Pa		Aislamiento Clase		F		Protección Térmica	
Por favor, indicar en los pedidos la alimentación deseada para el ventilador / Please indicate the required fan supply voltage when placing your order				Insulation Class		PTC 140 °C		Ambiente	
				Reference Standards		EN60034		Comutación Variador	
								4 kHz; du/dt TS60034-25 Type B	
<b>Freno de Bloqueo (opcional)</b> <b>Holding Brake (optional)</b>		300 Nm		24 Vdc		2.5 A		60 W	
		18 Kg		J = 0.0017 Kg m <sup>2</sup>					
Tensión de Base del Motor Motor Base Voltage		Vb		400 V		Tensión Máxima de Salida del Convertidor Inverter max. Output Voltage		Vc	
								400 V	

Bobinado Winding	Servicio / Service S1						Servicio / Service S6 - 40%						Corriente en vacío No Load Current (A)
	Nm	A	KW	rpm	Hz	Velocidad a Pot.Cte Const. Power Speed. (rpm)	Nm	A	KW	rpm	Hz	Velocidad a Pot.Cte Const. Power Speed. (rpm)	
A61	1750	182	92	500	26,0	780	2602	260	136	500	26,3	570	67
B61	1750	246	125	681	35,0	1060	2597	349	185	681	35,3	780	98
C61	1750	312	161	881	45,0	1370	2598	443	240	881	45,3	1010	123
D61	1750	343	180	981	50,0	1520	2600	490	267	981	50,3	1120	131
E61	1750	384	202	1100	56,0	1710	2600	548	299	1100	56,3	1260	146
F61	1750	429	227	1240	63,0	1930	2601	612	338	1240	63,3	1420	160
G61	1750	490	260	1420	72,0	2210	2601	699	387	1420	72,3	1620	184
H61	1750	571	304	1661	84,0	2590	2601	815	452	1661	84,3	1910	216

Otras Velocidades disponibles bajo consulta a nuestra O.T. / Other speeds available under request

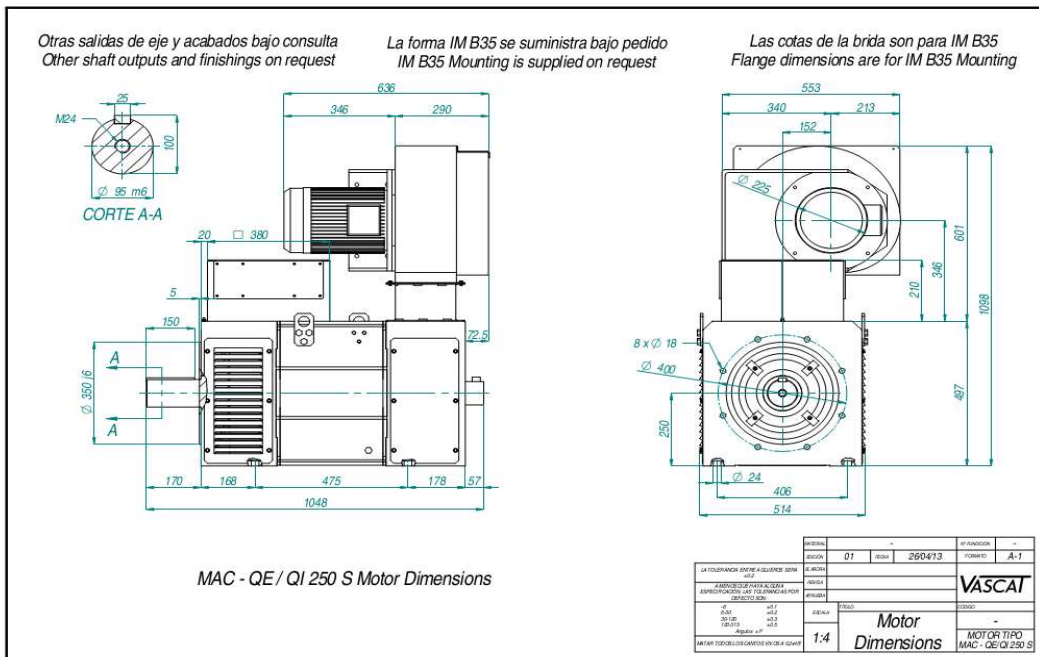

Datos Técnicos sujetos a modificaciones sin previo aviso / Technical data are subject to changes without prior notice

Elabora:	Revisa:	Aprueba:
David Gil	Jordi Trullen	Jordi Trullen
18/05/2015 17:08:33	18/05/2015 18:11:06	18/05/2015 18:11:14



# MOTOR MAC QI 250 M

- Hoja de Datos Técnicos -  
- Technical Datasheet -

Código DT-QI250M  
Edición 09  
Página 1/2  
Fecha 25/03/2015

Ventilador / Fan		Rodamientos			Delantero		Trasero			
Tipo de Refrigeración <i>Cooling Mode</i>	IC 06	6224.C3			6224.C3		6316.C3.J20AA			
Alimentación / Supply	400V 50Hz	Nº de polos <i>No of poles</i>	6	Momento de inercia <i>Rotor Inertia</i>	J=2,303 Kg m <sup>2</sup>		Peso Motor <i>Motor Weight</i>		1050 Kg	
Potencia / Power	4 KW	Protección <i>Protection Degree</i>		Construcción <i>Mounting</i>		Equilibrado grado <i>Balancing degree</i>				
Corriente / Current	7,6 A	IP 23		IM B3 / B35		A				
Velocidad / Speed	2885 rpm	Nivel de ruido <i>Noise Level</i>			Velocidad máxima mecánica <i>Max. Mechanical Speed</i>					
Caudal / Air flow	3210 m <sup>3</sup> /h	< 85 dB			4000 rpm					
Presión / Pressure	2450 Pa	Aislamiento Clase <i>Insulation Class</i>		Protección Térmica <i>Thermal Protection</i>		Ambiente <i>Ambient</i>		< 40 °C < 1000 m		
Por favor, indicar en los pedidos la alimentación deseada para el ventilador / Please indicate the required fan supply voltage when placing your order		F		PTC 140 °C						
		Normas de referencia <i>Reference Standards</i>		Comutación Variador <i>Inverter Switching</i>						
		EN60034		4 kHz; du/dt TS60034-25 Type B						
<b>Freno de Bloqueo (opcional)</b> <i>Holding Brake (optional)</i>		300 Nm		24 Vdc		2.5 A		60 W	18 Kg	J = 0.0017 Kg m <sup>2</sup>
Tensión de Base del Motor <i>Motor Base Voltage</i>		Vb		400 V		Tensión Máxima de Salida del Convertidor <i>Inverter max. Output Voltage</i>		Vc	400 V	

Bobinado <i>Winding</i>	Servicio / Service S1						Servicio / Service S6 - 40%						Corriente en vacío <i>No Load Current</i> (A)
	Nm	A	KW	rpm	Hz	Velocidad a Pot.Cte <i>Const. Power Speed</i> (rpm)	Nm	A	KW	rpm	Hz	Velocidad a Pot.Cte <i>Const. Power Speed</i> (rpm)	
A61	2270	189	95	399	21,0	630	3390	276	142	399	21,3	460	51
B61	2270	244	124	522	27,0	820	3372	348	184	522	27,3	600	94
C61	2270	312	162	681	35,0	1080	3374	446	241	681	35,3	790	117
D61	2270	341	176	742	38,0	1170	3371	484	262	742	38,3	860	133
E61	2270	381	200	841	43,0	1330	3374	544	297	841	43,3	980	143
F61	2270	425	224	942	48,0	1490	3373	606	332	942	48,3	1090	162
G61	2270	485	257	1082	55,0	1710	3373	692	382	1082	55,3	1260	184
H61	2100	532	278	1263	64,0	2000	3112	750	411	1263	64,3	1470	224
F62	1850	627	326	1685	85,0	2670	2736	874	482	1685	85,2	1970	282

Otras Velocidades disponibles bajo consulta a nuestra O.T. / Other speeds available under request

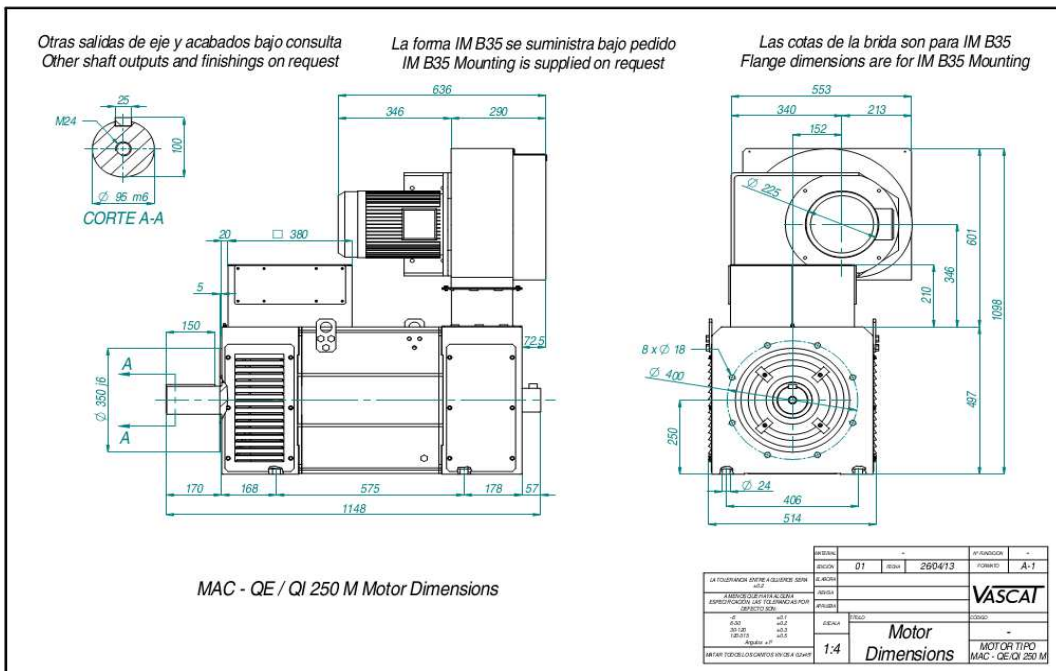

Datos Técnicos sujetos a modificaciones sin previo aviso / Technical data are subject to changes without prior notice

Elabora: <b>David Gil</b> 18/05/2015 17:17:33	Revisa: <b>Jordi Trullen</b> 18/05/2015 18:11:29	Aprueba: <b>Jordi Trullen</b> 18/05/2015 18:11:38
---	--	---



# MOTOR MAC QI 250 L

- Hoja de Datos Técnicos -  
- Technical Datasheet -

Código DT-QI250L  
Edición 09  
Página 1/2  
Fecha 25/03/2015

Ventilador / Fan		Rodamientos				Delantero		Trasero	
Tipo de Refrigeración Cooling Mode		IC 06		6224.C3		Drive End		6316.C3.J20AA Non Drive End	
Alimentación / Supply		400V 50Hz		Nº de polos No of poles		6		Momento de inercia Rotor Inertia	
Potencia / Power		4 KW		J=2,833 Kg m <sup>2</sup>		Peso Motor Motor Weight		1199 Kg	
Corriente / Current		7,6 A		Protección Protection Degree		IP 23		Construcción Mounting	
Velocidad / Speed		2885 rpm		IM B3 / B35		Equilibrado grado Balancing degree		A	
Caudal / Air flow		3210 m <sup>3</sup> /h		Nivel de ruido Noise Level		< 85 dB		Velocidad máxima mecánica Max. Mechanical Speed	
Presión / Pressure		2450 Pa		Aislamiento Clase Insulation Class		F		Protección Térmica Thermal Protection	
Por favor, indicar en los pedidos la alimentación deseada para el ventilador / Please indicate the required fan supply voltage when placing your order				PTC 140 °C		Ambiente Ambient		< 40 °C < 1000 m	
Normas de referencia Reference Standards		EN60034		Comutación Variador Inverter Switching		4 kHz; du/dt TS60034-25 Type B			
<b>Freno de Bloqueo (opcional) Holding Brake (optional)</b>		300 Nm		24 Vdc		2.5 A		60 W	
								18 Kg	
								J = 0.0017 Kg m <sup>2</sup>	
Tensión de Base del Motor Motor Base Voltage		Vb		400 V		Tensión Máxima de Salida del Convertidor Inverter max. Output Voltage		Vc	
								400 V	

Bobinado Winding	Servicio / Service S1						Servicio / Service S6 - 40%						Corriente en vacío No Load Current (A)
	Nm	A	KW	rpm	Hz	Velocidad a Pot.Cte Const. Power Speed. (rpm)	Nm	A	KW	rpm	Hz	Velocidad a Pot.Cte Const. Power Speed. (rpm)	
A61	2810	183	89	302	16,0	490	4177	262	132	302	16,3	360	69
B61	2810	247	124	422	22,0	690	4176	353	184	422	22,3	500	93
C61	2810	310	160	542	28,0	880	4175	443	237	542	28,3	640	118
D61	2810	341	177	602	31,0	980	4177	488	263	602	31,3	720	128
E61	2810	379	195	662	34,0	1080	4171	537	289	662	34,3	790	151
F61	2810	425	224	762	39,0	1240	4177	608	333	762	39,3	910	158
G61	2810	486	254	862	44,0	1410	4171	690	377	862	44,3	1040	192
H61	2810	566	301	1022	52,0	1670	4176	808	447	1022	52,3	1230	215
F62	2500	671	352	1344	68,0	2200	3702	942	521	1344	68,3	1620	289
G62	2250	709	364	1546	78,0	2530	3321	981	537	1546	78,2	1870	335

Otras Velocidades disponibles bajo consulta a nuestra O.T. / Other speeds available under request

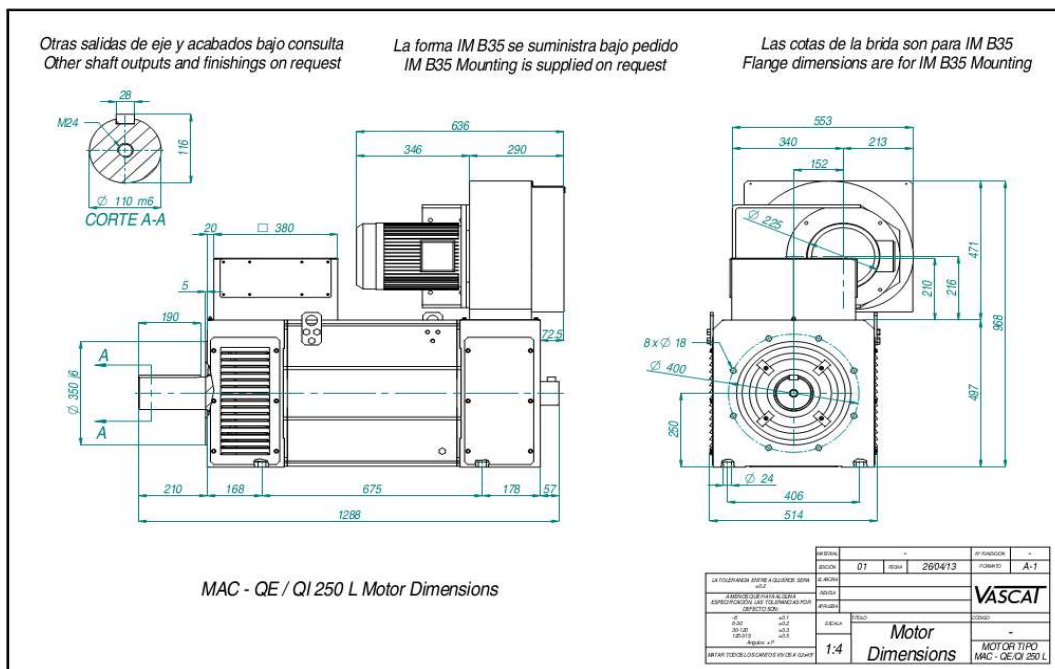

Datos Técnicos sujetos a modificaciones sin previo aviso / Technical data are subject to changes without prior notice

Elabora: <b>David Gil</b> 18/05/2015 17:38:25	Revisa: <b>Jordi Trullen</b> 18/05/2015 18:12:16	Aprueba: <b>Jordi Trullen</b> 18/05/2015 18:12:27
---	--	---



# MOTOR MAC QI 250 P

- Hoja de Datos Técnicos -  
- Technical Datasheet -

Código DT-QI250P  
Edición 09  
Página 1/2  
Fecha 25/03/2015

Ventilador / Fan		Rodamientos		Delantero		Trasero	
Tipo de Refrigeración Cooling Mode		IC 06		6224.C3		6316.C3.J20AA	
Alimentación / Supply		400V 50Hz		Nº de polos No of poles		6	
Potencia / Power		4 KW		Momento de inercia Rotor Inertia		J=3,362 Kg m <sup>2</sup>	
Corriente / Current		7,6 A		Protección Protection Degree		IP 23	
Velocidad / Speed		2885 rpm		Construcción Mounting		IM B3 / B35	
Caudal / Air flow		3210 m <sup>3</sup> /h		Nivel de ruido Noise Level		< 85 dB	
Presión / Pressure		2450 Pa		Velocidad máxima mecánica Max. Mechanical Speed		4000 rpm	
Por favor, indicar en los pedidos la alimentación deseada para el ventilador / Please indicate the required fan supply voltage when placing your order		Aislamiento Clase Insulation Class		F		Protección Térmica Thermal Protection	
		Normas de referencia Reference Standards		EN60034		Comutación Variador Inverter Switching	
				4 kHz; du/dt TS60034-25 Type B		Ambiente Ambient	
				< 40 °C < 1000 m			
<b>Freno de Bloqueo (opcional) Holding Brake (optional)</b>		300 Nm		24 Vdc		2.5 A	
		60 W		18 Kg		J = 0.0017 Kg m <sup>2</sup>	
Tensión de Base del Motor Motor Base Voltage		<b>Vb 400 V</b>		Tensión Máxima de Salida del Convertidor Inverter max. Output Voltage		<b>Vc 400 V</b>	

Bobinado Winding	Servicio / Service S1						Servicio / Service S6 - 40%						Corriente en vacío No Load Current (A)
	Nm	A	KW	rpm	Hz	Velocidad a Pot.Cte Const. Power Speed. (rpm)	Nm	A	KW	rpm	Hz	Velocidad a Pot.Cte Const. Power Speed. (rpm)	
A61	3350	184	85	243	13,0	410	4970	260	126	243	13,3	300	74
B61	3350	246	120	343	18,0	580	4971	349	178	343	18,3	420	99
C61	3350	312	155	443	23,0	750	4968	441	230	443	23,3	550	128
D61	3350	345	176	502	26,0	850	4977	492	262	502	26,3	620	132
E61	3350	382	197	562	29,0	950	4978	545	293	562	29,3	700	145
F61	3350	426	219	623	32,0	1060	4970	603	324	623	32,3	780	173
G61	3350	486	253	723	37,0	1230	4974	691	376	723	37,3	900	190
H61	3350	567	296	843	43,0	1430	4971	804	439	843	43,3	1050	228
F62	3200	715	376	1123	57,0	1910	4745	1010	558	1123	57,3	1410	295
G62	3000	768	403	1284	65,0	2180	4440	1075	597	1284	65,3	1610	338
H62	2750	844	434	1506	76,0	2560	4059	1168	640	1506	76,2	1890	398

Otras Velocidades disponibles bajo consulta a nuestra O.T. / Other speeds available under request

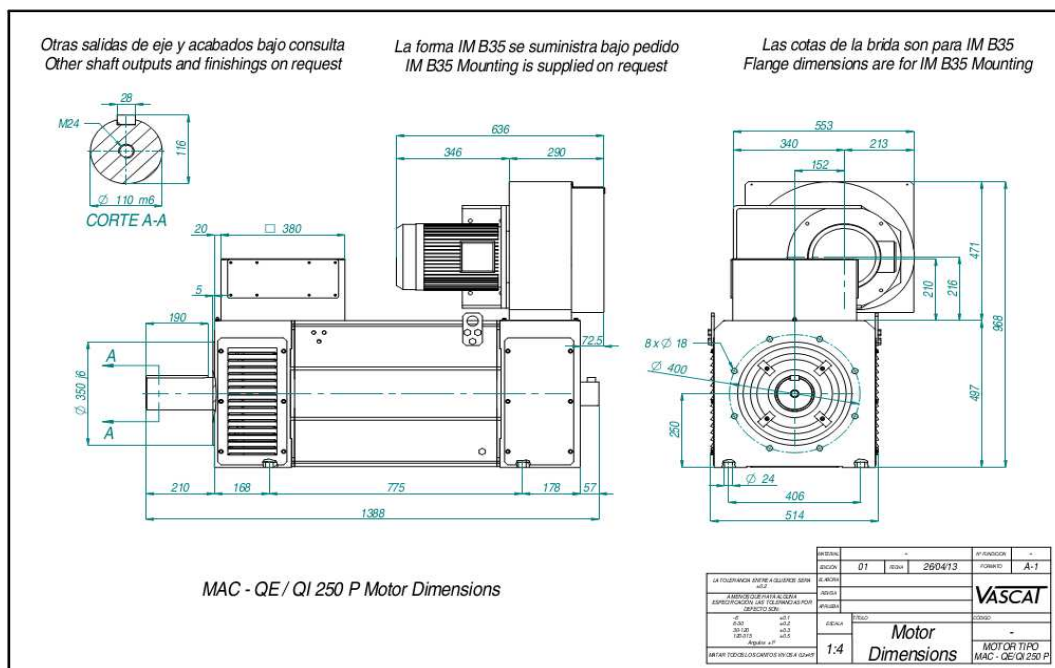

Datos Técnicos sujetos a modificaciones sin previo aviso / Technical data are subject to changes without prior notice

Elabora:	Revisa:	Aprueba:
David Gil 18/05/2015 17:41:59	Jordi Trullen 18/05/2015 18:12:43	Jordi Trullen 18/05/2015 18:12:52



## MOTOR MAC QI 250 X

- Hoja de Datos Técnicos -  
- Technical Datasheet -

Código DT-QI250X  
Edición 09  
Página 1/2  
Fecha 25/03/2015

Ventilador / Fan		Rodamientos		Delantero		Trasero	
Tipo de Refrigeración	IC 06	Bearings		6224.C3		6316.C3.J20AA	
Alimentación / Supply	400V 50Hz	Nº de polos	6	Momento de inercia	J=3,574 Kg m <sup>2</sup>	Peso Motor	1425 Kg
Potencia / Power	4 KW	Protección		Construcción		Equilibrado grado	
Corriente / Current	7,6 A	Protection Degree		Mounting		Balancing degree	
Velocidad / Speed	2885 rpm	IP 23		IM B3 / B35		A	
Caudal / Air flow	3210 m <sup>3</sup> /h	Nivel de ruido		Velocidad máxima mecánica		4000 rpm	
Presión / Pressure	2450 Pa	Noise Level		Max. Mechanical Speed			
Por favor, indicar en los pedidos la alimentación deseada para el ventilador / Please indicate the required fan supply voltage when placing your order		Aislamiento Clase		Protección Térmica		Ambiente	
		Insulation Class		Thermal Protection		Ambient	
		F		PTC 140 °C		< 40 °C < 1000 m	
		Normas de referencia		Conmutación Variador		4 kHz; du/dt TS60034-25 Type B	
		Reference Standards		Inverter Switching			
		EN60034					
<b>Freno de Bloqueo (opcional)</b>		300 Nm		24 Vdc		2.5 A	
<b>Holding Brake (optional)</b>				60 W		18 Kg	
						J = 0.0017 Kg m <sup>2</sup>	
Tensión de Base del Motor		Vb		400 V		Tensión Máxima de Salida del Convertidor	
Motor Base Voltage						Vc	
						400 V	

Bobinado Winding	Servicio / Service S1						Servicio / Service S6 - 40%						Corriente en vacío No Load Current (A)
	Nm	A	KW	rpm	Hz	Velocidad a Pot. Cte Const. Power Speed. (rpm)	Nm	A	KW	rpm	Hz	Velocidad a Pot. Cte Const. Power Speed. (rpm)	
A61	3550	184	86	232	12,5	380	5276	263	128	232	12,8	280	69
B61	3550	245	120	323	17,0	530	5271	349	178	323	17,3	390	96
C61	3550	310	157	423	22,0	700	5274	442	233	423	22,3	510	118
D61	3550	341	172	463	24,0	760	5268	484	255	463	24,3	560	137
E61	3550	378	194	523	27,0	860	5273	538	289	523	27,3	630	145
F61	3550	425	217	583	30,0	960	5265	601	321	583	30,3	700	174
G61	3550	489	254	683	35,0	1130	5271	695	377	683	35,3	830	191
H61	3550	570	298	802	41,0	1330	5272	810	443	802	41,3	980	222
F62	3400	709	372	1044	53,0	1730	5039	999	551	1044	53,3	1270	297
G62	3200	772	404	1205	61,0	2000	4737	1082	598	1205	61,2	1470	337
H62	2950	846	441	1427	72,0	2360	4361	1178	651	1427	72,2	1740	384

Otras Velocidades disponibles bajo consulta a nuestra O.T. / Other speeds available under request

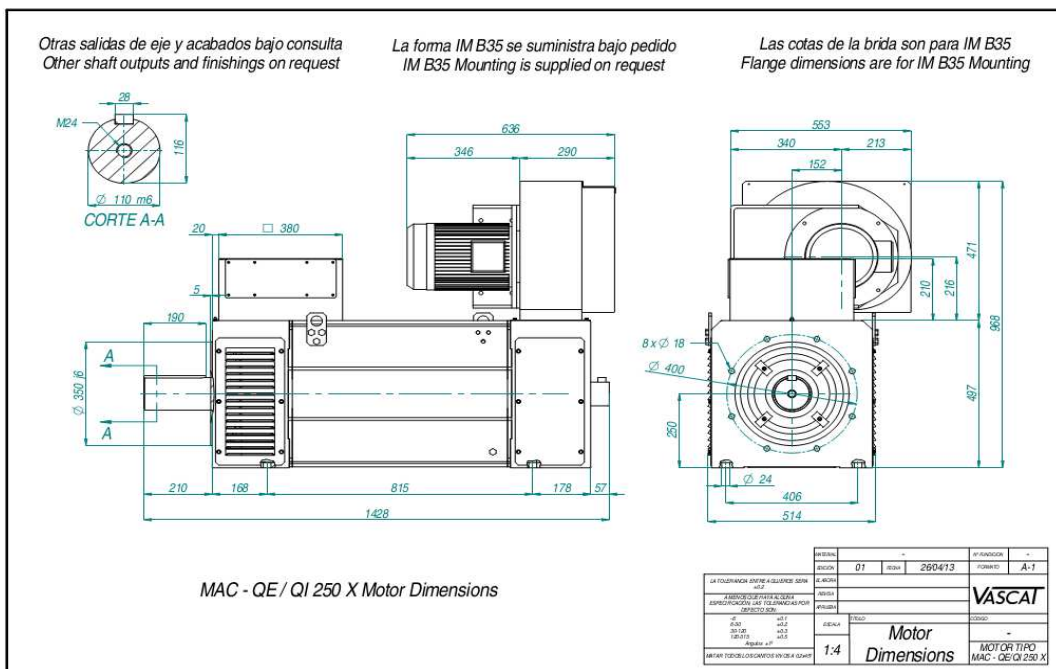

Datos Técnicos sujetos a modificaciones sin previo aviso / Technical data are subject to changes without prior notice

Elabora:	David Gil	18/05/2015 17:45:14	Revisa:	Jordi Trullen	18/05/2015 18:13:09	Aprueba:	Jordi Trullen	18/05/2015 18:13:17
----------	-----------	---------------------	---------	---------------	---------------------	----------	---------------	---------------------



# MOTOR MAC QI 315 S

- Hoja de Datos Técnicos -  
- Technical Datasheet -

Código DT-QI315S  
Edición 02  
Página 1/2  
Fecha 02/04/2015

<b>Ventilador / Fan</b>		Rodamientos <i>Bearings</i>	Delantero <i>Drive End</i>	6226.M.C3	Trasero <i>Non Drive End</i>	6320M.C3.J20AA	
Tipo de Refrigeración <i>Cooling Mode</i>	IC 06	Nº de polos <i>No of poles</i>	6	Momento de inercia <i>Rotor Inertia</i>	J = 8,88 Kg m <sup>2</sup>	Peso Motor <i>Motor Weight</i>	1760 Kg
Alimentación / Supply	400V 50Hz	Protección <i>Protection Degree</i>	IP 23	Construcción <i>Mounting</i>	IM B3 / B35	Equilibrado grado <i>Balancing degree</i>	A
Potencia / Power	4 KW	Nivel de ruido <i>Noise Level</i>	< 90 dB	Velocidad máxima mecánica <i>Max. Mechanical Speed</i>	3500 rpm		
Corriente / Current	7,6 A	Aislamiento Clase <i>Insulation Class</i>	F	Protección Térmica <i>Thermal Protection</i>	PTC 140 °C	Ambiente <i>Ambient</i>	< 40 °C < 1000 m
Velocidad / Speed	2900 rpm	Normas de referencia <i>Reference Standards</i>	EN60034	Conmutación Variador <i>Inverter Switching</i>	2 kHz ; du/dt TS60034-25 Type B		
Caudal / Air flow	4000 m3/h	Por favor, indicar en los pedidos la alimentación deseada para el ventilador / Please indicate the required fan supply voltage when placing your order					
Presión / Pressure	2450 Pa						
Tensión de Base del Motor <i>Motor Base Voltage</i>		Vb	400 V	Tensión Máxima de Salida del Convertidor <i>Inverter max. Output Voltage</i>		Vc	400 V

Bobinado <i>Winding</i>	Servicio / Service S1						Servicio / Service S6 - 40%						Corriente en vacío <i>No Load Current (A)</i>
	Nm	A	KW	rpm	Hz	Velocidad a Pot.Cte <i>Const. Power Speed (rpm)</i>	Nm	A	KW	rpm	Hz	Velocidad a Pot.Cte <i>Const. Power Speed (rpm)</i>	
A61	4200	428	231	526	27,0	920	6255	617	344	526	27,3	610	144
B61	4200	471	258	586	30,0	1020	6258	681	384	586	30,4	680	154
C61	4200	528	293	665	34,0	1160	6263	767	436	665	34,4	770	162
D61	4200	590	328	745	38,0	1300	6261	855	488	745	38,4	870	186
E61	4200	679	380	865	44,0	1510	6264	986	567	865	44,4	1010	208
F61	4000	755	421	1006	51,0	1760	5957	1089	627	1006	51,3	1180	254
C62	3650	803	446	1168	59,0	2040	5426	1147	663	1168	59,3	1370	299
D62	3300	831	452	1309	66,0	2290	4890	1170	670	1309	66,3	1540	351
E62	2900	864	459	1510	76,0	2640	4281	1196	677	1510	76,2	1780	406

Otras Velocidades disponibles bajo consulta a nuestra O.T. / Other speeds available on request

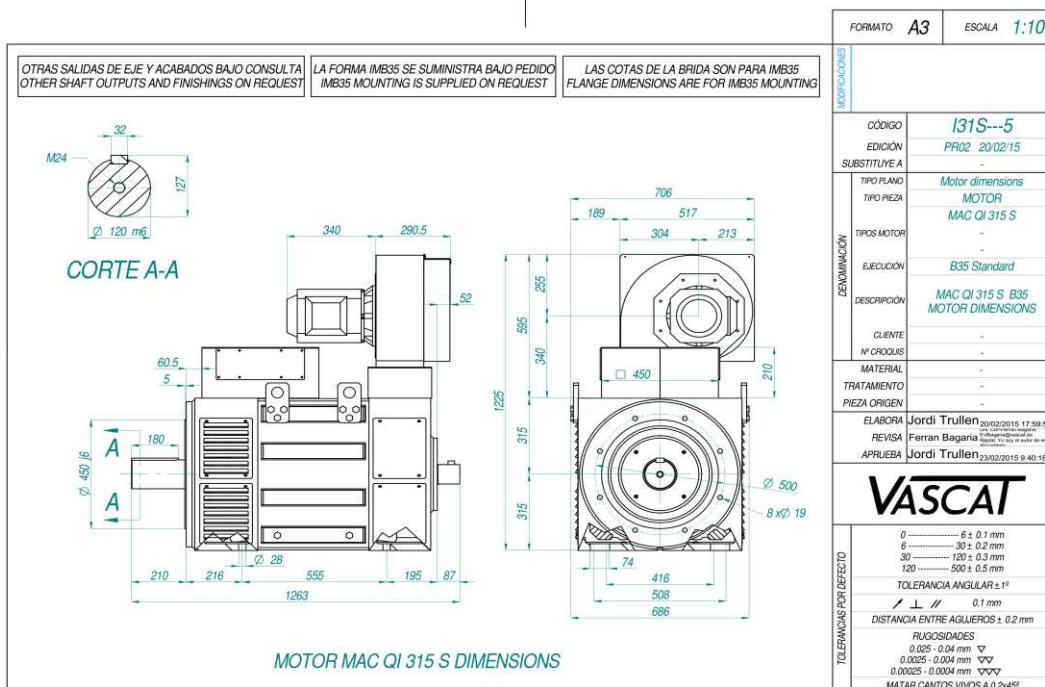

Datos Técnicos sujetos a modificaciones sin previo aviso / Technical Data are subject to changes without prior notice

Elabora: <b>David Gil</b> 04/09/2015 10:12:53	Revisa: <b>Jordi Trullen</b> 04/09/2015 10:22:39	Aprueba: <b>Jordi Trullen</b> 04/09/2015 10:22:50
---	--	---





# MOTOR MAC QI 315 M

- Hoja de Datos Técnicos -  
- Technical Datasheet -

Código DT-QI315M  
Edición 01  
Página 1/2  
Fecha 02/03/2015

<b>Ventilador / Fan</b>		Rodamientos <i>Bearings</i>	Delantero <i>Drive End</i>	6226.M.C3	Trasero <i>Non Drive End</i>	6320M.C3.J20AA	
Tipo de Refrigeración <i>Cooling Mode</i>	IC 06	Nº de polos <i>No of poles</i>	6	Momento de inercia <i>Rotor Inertia</i>	J = 10,98 Kg m <sup>2</sup>	Peso Motor <i>Motor Weight</i>	2020 Kg
Alimentación / Supply	400V 50Hz	Protección <i>Protection Degree</i>	IP 23	Construcción <i>Mounting</i>	IM B3 / B35	Equilibrado grado <i>Balancing degree</i>	A
Potencia / Power	4 KW	Nivel de ruido <i>Noise Level</i>	< 90 dB	Velocidad máxima mecánica <i>Max. Mechanical Speed</i>	3500 rpm		
Corriente / Current	7.6 A	Aislamiento Clase <i>Insulation Class</i>	F	Protección Térmica <i>Thermal Protection</i>	PTC 140 °C	Ambiente <i>Ambient</i>	< 40 °C < 1000 m
Velocidad / Speed	2900 rpm	Normas de referencia <i>Reference Standards</i>	EN60034	Conmutación Variador <i>Inverter Switching</i>	2 kHz ; du/dt TS60034-25 Type B		
Caudal / Air flow	4000 m3/h	Por favor, indicar en los pedidos la alimentación deseada para el ventilador / Please indicate the required fan supply voltage when placing your order					
Presión / Pressure	2450 Pa	Tensión de Base del Motor <i>Motor Base Voltage</i>		Vb	400 V	Tensión Máxima de Salida del Convertidor <i>Inverter max. Output Voltage</i>	
				Vc	400 V		

Bobinado <i>Winding</i>	Servicio / Service S1						Servicio / Service S6 - 40%						Corriente en vacío <i>No Load Current (A)</i>
	Nm	A	KW	rpm	Hz	Velocidad a Pot.Cte <i>Const. Power Speed (rpm)</i>	Nm	A	KW	rpm	Hz	Velocidad a Pot.Cte <i>Const. Power Speed (rpm)</i>	
A61	5200	418	222	407	21,0	730	7733	598	330	407	21,2	490	153
B61	5200	468	254	466	24,0	830	7747	676	378	466	24,2	550	154
C61	5200	523	287	526	27,0	940	7750	757	427	526	27,2	630	168
D61	5200	583	319	587	30,0	1050	7744	840	476	587	30,2	700	197
E61	5200	671	374	686	35,0	1230	7751	972	557	686	35,2	820	214
F61	5200	783	439	806	41,0	1450	7752	1135	654	806	41,2	970	248
C62	5000	867	486	927	47,0	1660	7443	1247	722	927	47,2	1110	300
D62	4600	909	505	1049	53,0	1880	6836	1297	750	1049	53,2	1260	342
E62	4200	967	532	1210	61,0	2170	6229	1368	789	1210	61,2	1460	395
F62	3700	1021	554	1431	72,0	2570	5474	1428	820	1431	72,1	1730	452

Otras Velocidades disponibles bajo consulta a nuestra O.T. / Other speeds available on request

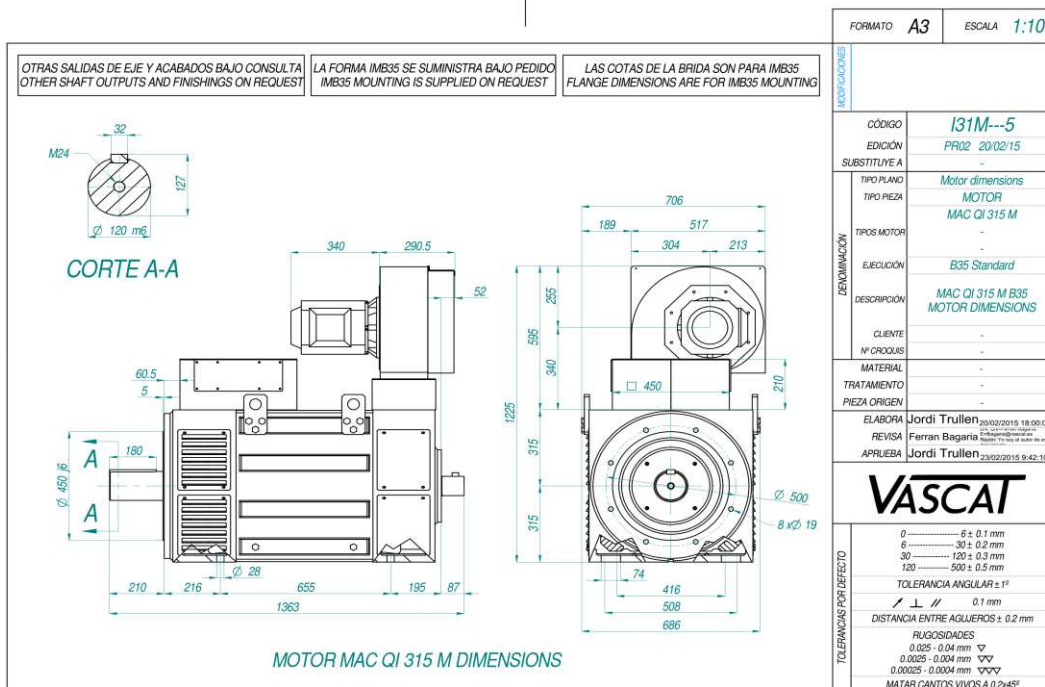

Datos Técnicos sujetos a modificaciones sin previo aviso / Technical Data are subject to changes without prior notice

Elabora: <b>David Gil</b> 02/03/2015 11:37:32	Revisa: <b>Jordi Trullen</b> 02/03/2015 16:07:24	Aprueba: <b>Jordi Trullen</b> 02/03/2015 16:07:35
---	--	---



### MOTOR MAC QI 315 L

- Hoja de Datos Técnicos -  
- Technical Datasheet -

Código DT-QI315L  
Edición 01  
Página 1/2  
Fecha 02/03/2015

<b>Ventilador / Fan</b>		Rodamientos <i>Bearings</i>	Delantero <i>Drive End</i>	6226.M.C3	Trasero <i>Non Drive End</i>	6320M.C3.J20AA	
Tipo de Refrigeración <i>Cooling Mode</i>	IC 06	Nº de polos <i>No of poles</i>	6	Momento de inercia <i>Rotor Inertia</i>	J = 13,09 Kg m <sup>2</sup>	Peso Motor <i>Motor Weight</i>	2280 Kg
Alimentación / Supply <i>Power</i>	400V 50Hz	Protección <i>Protection Degree</i>	IP 23	Construcción <i>Mounting</i>	IM B3 / B35	Equilibrado grado <i>Balancing degree</i>	A
Corriente / Current	7.6 A	Nivel de ruido <i>Noise Level</i>	< 90 dB	Velocidad máxima mecánica <i>Max. Mechanical Speed</i>	3500 rpm		
Velocidad / Speed	2900 rpm	Aislamiento Clase <i>Insulation Class</i>	F	Protección Térmica <i>Thermal Protection</i>	PTC 140 °C	Ambiente <i>Ambient</i>	< 40 °C < 1000 m
Caudal / Air flow	4000 m <sup>3</sup> /h	Normas de referencia <i>Reference Standards</i>	EN60034	Conmutación Variador <i>Inverter Switching</i>	2 kHz ; du/dt TS60034-25 Type B		
Presión / Pressure	2450 Pa	Por favor, indicar en los pedidos la alimentación deseada para el ventilador / Please indicate the required fan supply voltage when placing your order					
Tensión de Base del Motor <i>Motor Base Voltage</i>		Vb	400 V	Tensión Máxima de Salida del Convertidor <i>Inverter max. Output Voltage</i>		Vc	400 V

Bobinado <i>Winding</i>	Servicio / Service S1						Servicio / Service S6 - 40%						Corriente en vacío <i>No Load Current (A)</i>
	Nm	A	KW	rpm	Hz	Velocidad a Pot.Cte <i>Const. Power Speed (rpm)</i>	Nm	A	KW	rpm	Hz	Velocidad a Pot.Cte <i>Const. Power Speed (rpm)</i>	
A61	6200	424	226	348	18,0	640	9232	610	336	348	18,2	430	144
B61	6200	466	252	387	20,0	710	9236	673	375	387	20,2	470	154
C61	6200	516	278	428	22,0	790	9228	741	413	428	22,2	530	180
D61	6200	580	317	488	25,0	900	9232	836	471	488	25,2	600	197
E61	6200	667	368	567	29,0	1040	9237	963	549	567	29,2	690	219
F61	6200	778	433	667	34,0	1230	9238	1124	645	667	34,2	820	254
C62	6200	891	499	768	39,0	1420	9232	1284	742	768	39,2	950	303
D62	5900	960	537	869	44,0	1600	8777	1378	798	869	44,2	1070	344
E62	5600	1056	592	1009	51,0	1860	8328	1512	880	1009	51,2	1250	385
F62	5200	1159	648	1190	60,0	2200	7725	1651	962	1190	60,2	1480	444

Otras Velocidades disponibles bajo consulta a nuestra O.T. / Other speeds available on request

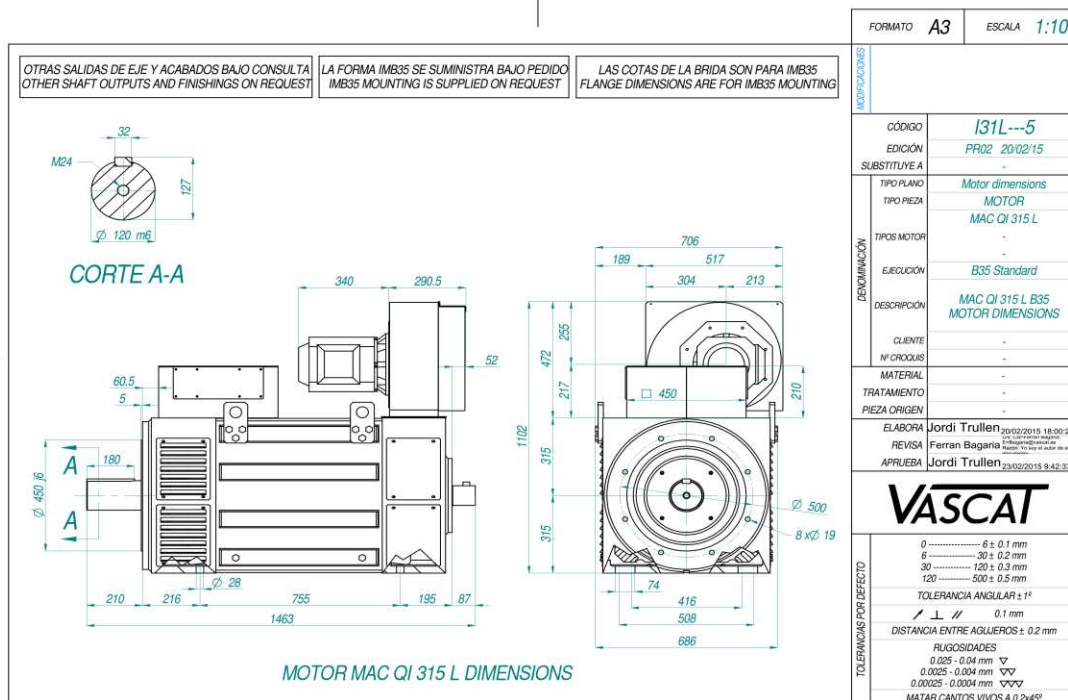

Datos Técnicos sujetos a modificaciones sin previo aviso / Technical Data are subject to changes without prior notice

Elabora: <b>David Gil</b> 09/03/2015 9:08:15	Revisa: <b>Jordi Trullen</b> 09/03/2015 11:50:02	Aprueba: <b>Jordi Trullen</b> 09/03/2015 11:50:13
--	--	---



### MOTOR MAC QI 315 P

- Hoja de Datos Técnicos -  
- Technical Datasheet -

Código DT-QI315P  
Edición 01  
Página 1/2  
Fecha 02/03/2015

<b>Ventilador / Fan</b>		Rodamientos <i>Bearings</i>	Delantero <i>Drive End</i>	6226.M.C3	Trasero <i>Non Drive End</i>	6320M.C3.J20AA	
Tipo de Refrigeración <i>Cooling Mode</i>	IC 06	Nº de polos <i>No of poles</i>	6	Momento de inercia <i>Rotor Inertia</i>	J = 15,20 Kg m <sup>2</sup>	Peso Motor <i>Motor Weight</i>	2540 Kg
Alimentación / Supply	400V 50Hz	Protección <i>Protection Degree</i>	IP 23	Construcción <i>Mounting</i>	IM B3 / B35	Equilibrado grado <i>Balancing degree</i>	A
Potencia / Power	4 KW	Nivel de ruido <i>Noise Level</i>	< 90 dB	Velocidad máxima mecánica <i>Max. Mechanical Speed</i>	3500 rpm		
Corriente / Current	7,6 A	Aislamiento Clase <i>Insulation Class</i>	F	Protección Térmica <i>Thermal Protection</i>	PTC 140 °C	Ambiente <i>Ambient</i>	< 40 °C < 1000 m
Velocidad / Speed	2900 rpm	Normas de referencia <i>Reference Standards</i>	EN60034	Conmutación Variador <i>Inverter Switching</i>	2 kHz ; du/dt TS60034-25 Type B		
Caudal / Air flow	4000 m <sup>3</sup> /h	Por favor, indicar en los pedidos la alimentación deseada para el ventilador / Please indicate the required fan supply voltage when placing your order					
Presión / Pressure	2450 Pa						
Tensión de Base del Motor <i>Motor Base Voltage</i>		Vb	400 V	Tensión Máxima de Salida del Convertidor <i>Inverter max. Output Voltage</i>		Vc	400 V

Bobinado <i>Winding</i>	Servicio / Service S1						Servicio / Service S6 - 40%						Corriente en vacío <i>No Load Current (A)</i>
	Nm	A	KW	rpm	Hz	Velocidad a Pot.Cte <i>Const. Power Speed (rpm)</i>	Nm	A	KW	rpm	Hz	Velocidad a Pot.Cte <i>Const. Power Speed (rpm)</i>	
A61	7200	416	218	289	15,0	530	10708	595	324	289	15,2	350	151
B61	7200	464	247	328	17,0	600	10721	669	368	328	17,2	400	159
C61	7200	515	278	368	19,0	680	10722	743	413	368	19,2	450	174
D61	7200	571	308	409	21,0	750	10712	820	458	409	21,2	500	204
E61	7200	666	368	488	25,0	900	10731	964	548	488	25,2	600	214
F61	7200	774	428	568	29,0	1050	10725	1117	638	568	29,2	700	258
C62	7200	893	504	668	34,0	1230	10732	1293	750	668	34,2	820	285
D62	6900	964	541	749	38,0	1380	10271	1388	805	749	38,2	920	334
E62	6600	1067	601	869	44,0	1600	9822	1533	893	869	44,2	1070	375
F62	6200	1178	656	1010	51,0	1860	9208	1677	973	1010	51,2	1250	457

Otras Velocidades disponibles bajo consulta a nuestra O.T. / Other speeds available on request

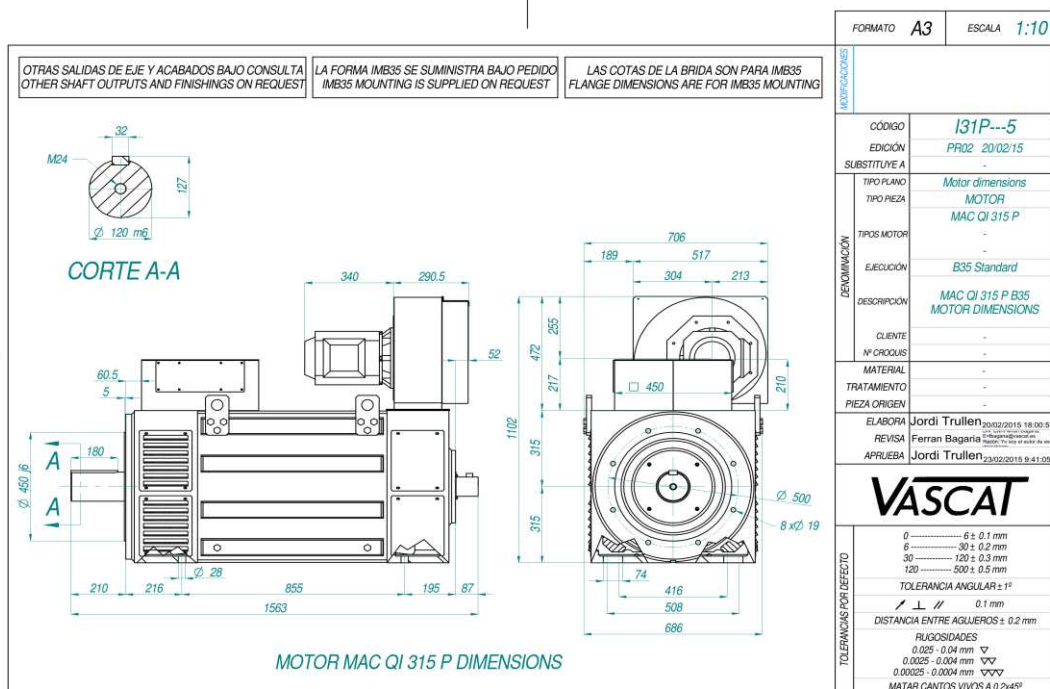

Datos Técnicos sujetos a modificaciones sin previo aviso / Technical Data are subject to changes without prior notice

Elabora: <b>David Gil</b> 02/03/2015 15:37:31	Revisa: <b>Jordi Trullen</b> 02/03/2015 16:05:58	Aprueba: <b>Jordi Trullen</b> 02/03/2015 16:06:08
---	--	---