

**TA SERIES INDUCTION  
ASYN. MOTORS INSTRUCTION FOR  
OPERATION AND MAINTENANCE**

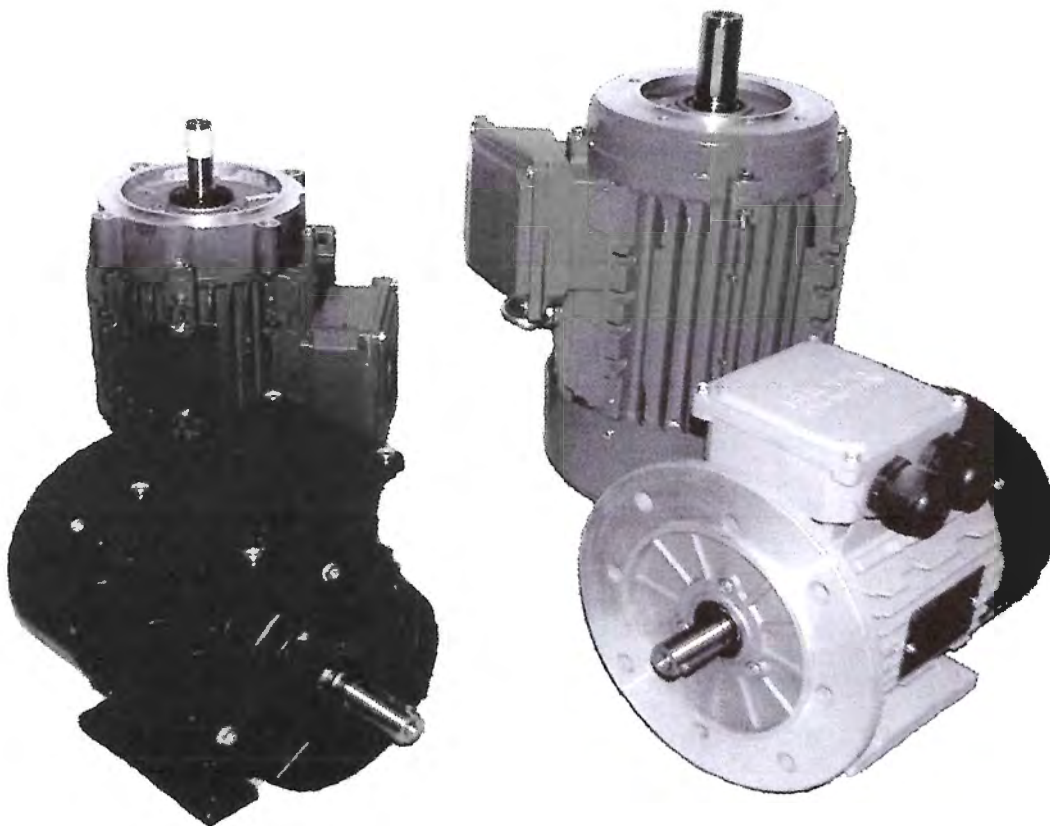

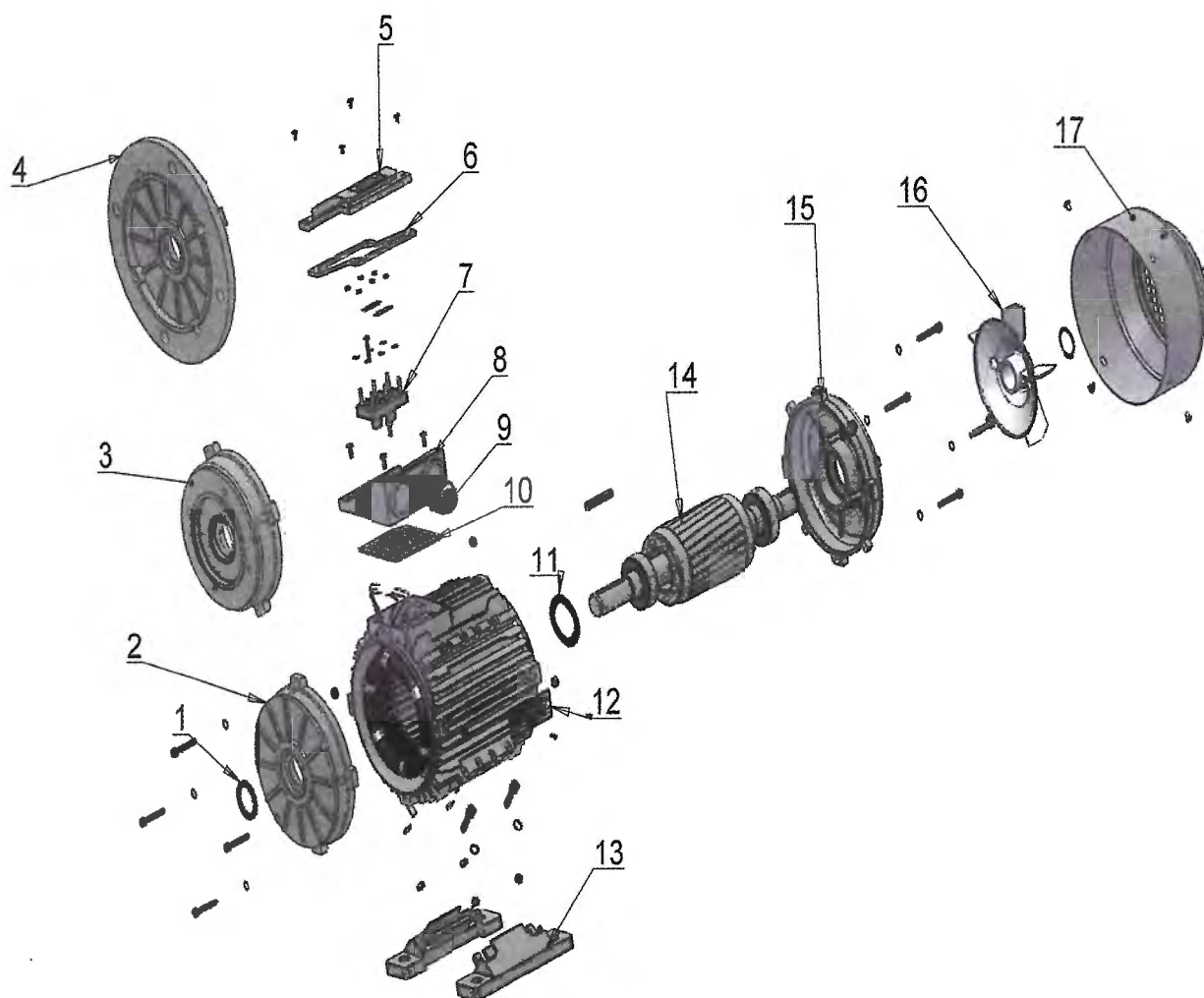

1. Oil seal
2. De endshield
3. B14 flange
4. B5 flange
5. Terminal box cover
6. Terminal box upper gasket
7. Terminal board
8. Terminal box base
9. Cable grand
10. Terminal box bottom gasket
11. Compensation washer
12. Nameplate
13. Foot
14. Rotor
15. NDE endshield
16. Cooling fan
17. Fan cover

### **I.Name of Model:**

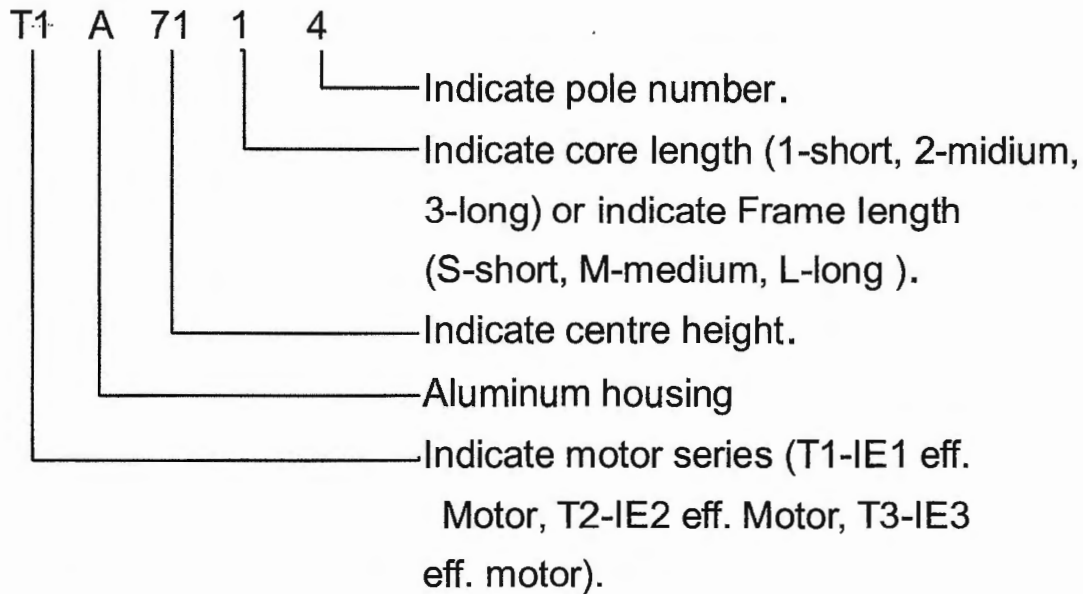

### **II. Transportation and Storage of the Motors:**

1. Transportation: During transportation, care must be taken to keep the motor in upright position and place it flat, without being invertedly or laterally laid. When being craned, it should be lifted or lowered slowly, but not jerkily. At the same time it should be kept the rain and dew away from invasion into the machine and making it damp.

2. Storage: The motors should be stored in a dry and well-ventilated.indoor storage.Should not be stored in a storage which is full of corrosive gas.

### **III. Preliminaries before operation:**

1. Check the insulation resistance: Before the motor is put into operation the insulation resistance between its winding, and that of the windings respect to ground with a megohm meter of 500V. The rate of the resistance is more than 1.0 megohm, otherwise, the winding should be treated with heat-baking. If it is available a voltage in the range of 1/3 to

1/2 of the rated value can be applied to get the motor running at no load one hour or so, until the dampness is expelled.

2. Check the line voltage: connected the line voltage in accordance with the value indicated on the nameplate of the motors. To the double voltage motor should be more care the motor voltage and power voltage just the same on the connection plate.

3. Inspection of the switch: The specification and capacity of the controlling switch should satisfy the requirements indicated on the name plate of the motor. (Such as current capacity size of fuse, etc).

4. Inspect the environment: The space surrounding the installation size of the motor should be free from any other corrosive gas. At the same time prevent water drops iron chips and cotton fibres to gain access into the motor. Ample free space should be provided around the motor to facilitate ventilation and heat dissipation.

5. Check ground connection: The frame of the motor should be grounded to insure safety.

6. Rotating Condition of the motor: Before the motor is installed the shaft extension slowly should be turned by hand to make sure that the rotor does not rub or knock against other parts but gives an easy and swift rotation. After the motor has been installed, check the driving belt or the coupler is mounted with good flexibility.

7. Wiring: Check the wiring connections before the motor is started. The motor can be started only when the wiring connection is made in accordance with the wiring diagram given on the terminal box. If want to change direction of the

motor you may see the wiring diagram to change connection method of the connection strip that may change the direction.

#### **IV.Maintenance of the motors:**

1. Daily cleaning: The motor in use should always be kept Clean. No water drops, cotton should be allowed to get into the interior of the motors.

2. Check on load current: While the motor is in operation, constant care should be taken to keep the load current below the rated value.

3. Running sound: During operation of the motor there must be needed no rubbing sound shriek and other random noise, you should stop the motor in time and begin to start it again only after correction has been done.

4. Temperature of the bearings should be below 95°C when the motor is running.

5. To the capacitor starting and resistance starting motors, rear end of the frame mounted with centrifugal switch. On the rear end of the motor base there is finished a quick-break centrifugal switch. When the motor is started and attains to a certain speed the switch will give a crisp sound of "click,click" and thus cut off the power. Supply to the secondary winding with the motor in normal run. When the motor fails to start or when it does start and attain a certain speed but accompanies with shock and shriek instead of the crisp click, cut off the power supply immediately and carefully inspect the centrifugal switch and the capacitor.

#### **V.Overhaul:**

In order to insure reliable operation the motor, which should be carried out at regular intervals, usually once a year.

# CONNECTION DIAGRAM

## TA series three-phase asyn. motor

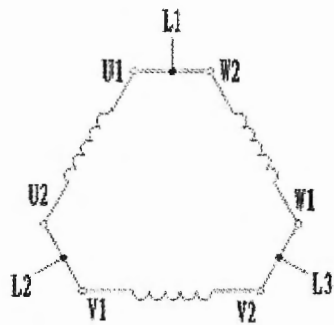

Figure

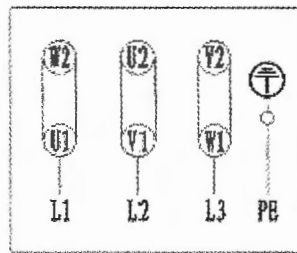

Connection diagram

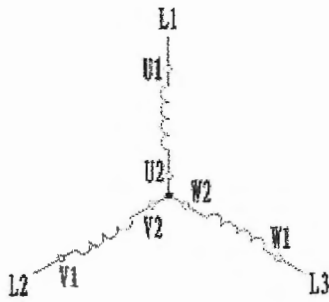

Figure

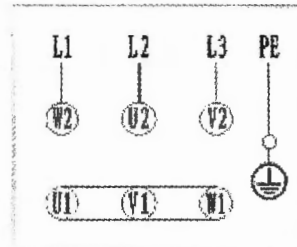
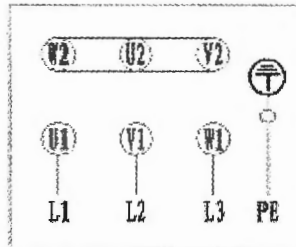

Connection diagram