

Operating Instructions INTORQ BFK 458-□□

Electromagnetically released spring-applied brake

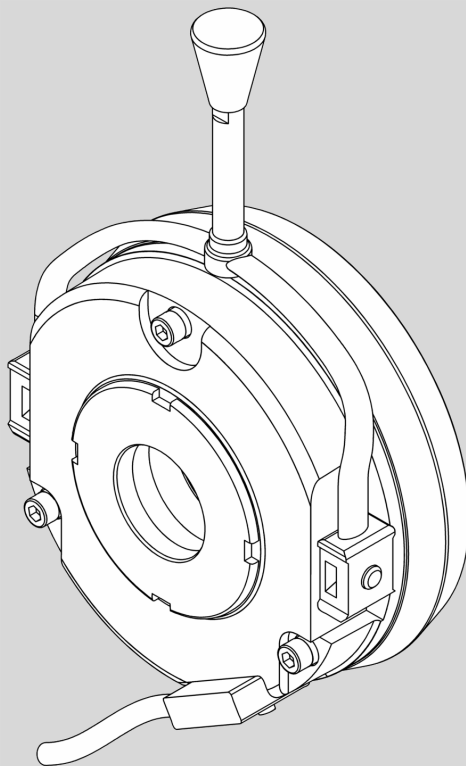

INTORQ

setting the standard

www.intorq.de

This documentation applies to ...

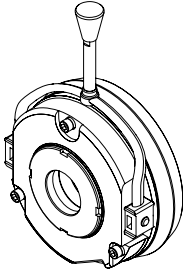
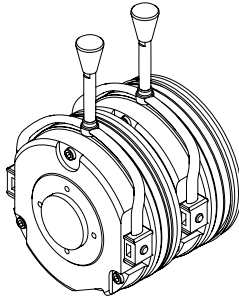
	Single version	Double version
INTORQ BFK458-06 <input type="checkbox"/>		
INTORQ BFK458-08 <input type="checkbox"/>		
INTORQ BFK458-10 <input type="checkbox"/>		
INTORQ BFK458-12 <input type="checkbox"/>		
INTORQ BFK458-14 <input type="checkbox"/>		
INTORQ BFK458-16 <input type="checkbox"/>		
INTORQ BFK458-18 <input type="checkbox"/>		
INTORQ BFK458-20 <input type="checkbox"/>		
INTORQ BFK458-25 <input type="checkbox"/>		

Product key

Product key

INTORQ B FK □□□ - □□ □

A	
B	
C	
D	
E	

Legend for the product key INTORQ BFK458

A	Product group	Braking
B	Product family	Spring-applied brake
C	Type	458
D	Size	06, 08, 10, 12, 14, 16, 18, 20, 25
E	Design	E - adjustable (brake torque can be reduced via adjuster nut) N - not adjustable

Not coded: Supply voltage, hub bore, options

Nameplate

Field	Content			Example
1	Manufacturer		CE marking	
2	Brake type			
3	Rated voltage	Rated power	Hub diameter	
4	Type no.	Rated torque	Date of manufacture	

Packaging sticker

Field	Content			Example
1	Manufacturer		Barcode no.	
2	Designation		Type no.	
3	Type see product key	Rated torque	Qty. per box	
4	Rated voltage / rated power		Date of packaging	
5			Addition / CE mark	

Document history

Material number	Version			Description
405520	1.0	08/1998	TD09	Initial edition for series
405520	1.1	05/2000	TD09	Address revision Changed values of brake torques in Tab. 1 and Tab. 3 Supplementation of Tab. 4, "operating times"
460730	2.0	11/2002	TD09	All chapters: Completely revised Change of company name Changed values of brake torques Amendment of drawings, Fig. 12, Fig. 13, Fig. 15, Fig. 16 and Fig. 17 New: Chapter 7.4 "Spare parts list for double spring-operated brake"
13040626	2.1	02/2005	TD09	Change of company name to INTORQ
13284675	3.0	01/2009	TD09	Change of tightening torques Supplementation of Tab. 5 Revision of chapter 3.6 Supplementation of chapter 7.1 and 7.2
13284675	3.1	01/2010	TD09	Change of the maintenance intervals for holding brakes with emergency stop
13343893	4.0	01/2010	TD09	Values of brake torque and speed modified (Tab. 3)

i Contents

1	Preface and general information	5
1.1	About these Operating Instructions	5
1.2	Terminology used	5
1.3	Scope of supply	5
1.4	Disposal	5
1.5	Drive systems	6
1.6	Legal regulations	6
2	Safety instructions	7
2.1	General safety information	7
2.2	Personnel responsible for safety	8
2.3	Notes used	9
3	Technical data	10
3.1	Product description	10
3.2	Brake torques	12
3.3	Rated data	14
3.4	Operating times	17
3.5	Operating frequency / friction work	19
3.6	Emission	20
4	Mechanical installation	21
4.1	Necessary tools	21
4.2	Mounting	22
4.3	Installation	22
5	Electrical installation	30
5.1	Bridge/half-wave rectifiers	30
5.2	Electrical connection	32
6	Commissioning and operation	36
6.1	Functional test	36
6.2	Reducing the brake torque	40
6.3	During operation	40
7	Maintenance/repair	41
7.1	Wear of spring-applied brakes	41
7.2	Inspections	42
7.3	Maintenance	43
7.4	Spare-parts list	46
7.5	Spare parts order	48
8	Troubleshooting and fault elimination	50

1 Preface and general information

1.1 About these Operating Instructions

- These Operating Instructions will help you to work safely on and with the spring-applied brake with electromagnetic release. They contain safety instructions that must be followed.
- All persons working on or with the electromagnetically released spring-applied brakes must have the Operating Instructions available and observe the information and notes relevant for them.
- The Operating Instructions must always be in a complete and perfectly readable condition.

1.2 Terminology used

Term	In the following text used for
Spring-applied brake	Spring-applied brake with electromagnetic release
Drive system	Drive systems with spring-applied brakes and other drive components

1.3 Scope of supply

- The drive systems are combined individually according to a modular design. The scope of delivery is indicated in the accompanying papers.
- After receipt of the delivery, check immediately whether it corresponds to the accompanying papers. INTORQ does not grant any warranty for deficiencies claimed subsequently. Claim
 - visible transport damage immediately to the forwarder.
 - visible deficiencies / incompleteness immediately to INTORQ GmbH & Co.KG.

1.4 Disposal

The spring-applied brake consists of different types of material.

- Recycle metals and plastics.
- Ensure professional disposal of assembled PCBs according to applicable environmental regulations.

1 Preface and general information

1.5 Drive systems

1.5.1 Labelling

Drive systems and components are unambiguously designated by the indications on the nameplate.

Manufacturer: INTORQ GmbH & Co KG, Wülmser Weg 5, D-31855 Aerzen

- The spring-applied INTORQ brake is also delivered in single modules and individually combined to its modular design. The data - package labels, nameplate, and type code in particular - apply to the complete stator.
- If single modules are delivered, the labelling is missing.

1.6 Legal regulations

Liability

- The information, data and notes in these Operating Instructions met the state of the art at the time of printing. Claims referring to drive systems which have already been supplied cannot be derived from the information, illustrations and descriptions.
- We do not accept any liability for damage and operating interference caused by:
 - inappropriate use
 - unauthorised modifications to the drive system
 - improper working on and with the drive system
 - operating faults
 - disregarding these Operating Instructions

Warranty

- Terms of warranty: see terms of sale and delivery of INTORQ GmbH & Co. KG.
- Warranty claims must be made to INTORQ immediately after detecting defects or faults.
- The warranty is void in all cases where liability claims cannot be made.

2 Safety instructions

2.1 General safety information

- These safety notes do not claim to be complete. If any questions or problems occur, please contact INTORQ GmbH & Co. KG.
- The spring-applied brake corresponds to the state of the art at the time of delivery and is generally safe to operate.
- The spring-applied brake presents a danger for persons, the spring-applied brake itself and other material assets of the operator if
 - non-qualified personnel work on and with the spring-applied brake.
 - the spring-applied brake is used improperly.
- The spring-applied brakes must be planned in such a way that if they are correctly installed and used for their designed purpose in fault-free operation, they fulfil their function and do not put any persons at risk. This also applies to the interaction thereof with the overall system.
- Take appropriate measures to ensure that the failure of the spring-applied brake will not lead to damage to material.
- Do not operate the spring-applied brake unless it is in perfect condition.
- Retrofittings, changes or alterations of the spring-applied brake are generally forbidden. In any case, they are subject to the consultation with INTORQ GmbH & Co. KG.
- The friction lining and the friction surfaces must be carefully protected from oil or grease since even small amounts of lubricants reduce the brake torque considerably.
- The brake torque will usually not be influenced if the brake is used under the environmental conditions that apply to IP54. Because of the numerous possibilities of using the brake, it is however necessary to check the functionality of all mechanical components under the corresponding operating conditions.

2 Safety instructions

2.2 Personnel responsible for safety

Operator

- An operator is any natural or legal person who uses the spring-applied brake or on whose behalf the spring-applied brake is used.
- The operator or his safety personnel must ensure
 - that all relevant regulations, notes and laws will be complied with,
 - that only qualified personnel will work on and with the drive system,
 - that the Operating Instructions will be available to the personnel working on and with the brake at all times,
 - that unqualified personnel will not be allowed to work on and with the spring-applied brake.

Skilled personnel

Skilled personnel are persons who - because of their education, experience, instructions, and knowledge about corresponding standards and regulations, rules for the prevention of accidents, and operating conditions - are authorised by the person responsible for the safety of the plant to perform the required actions and who are able to recognise potential hazards. (See IEC 364, definition of skilled personnel)

Application as directed

- Drive systems
 - are intended for use in machinery and systems.
 - are suitable for use in potentially explosive atmospheres of zone II for steady operation (holding or parking brake), explosion group II and temperature class T4.
 - must only be used for the purposes ordered and confirmed.
 - must only be operated under the ambient conditions prescribed in these Operating Instructions.
 - must not be operated beyond their corresponding power limits.

Any other use shall be deemed inappropriate!

Possible applications of the INTORQ spring-applied brake

- No explosive or aggressive atmosphere.
- Humidity, no restrictions.
- Ambient temperature -20°C to +40°C.
- With high humidity and low temperatures
 - Take measures to protect armature plate and rotor from freezing.
- Protect electrical connections against contact.

2 Safety instructions

2.3 Notes used

The following pictographs and signal words are used in this documentation to indicate dangers and important information:

Safety instructions



Structure of safety instructions:

 **Danger!**
 Characterises the type and severity of danger



Note
 Describes the danger

Possible consequences:
 ■ List of possible consequences if the safety instructions are disregarded.

Protective measure:
 ■ List of protective measures to avoid the danger.

Pictograph and signal word	Meaning
 Danger!	Danger of personal injury through dangerous electrical voltage Reference to an imminent danger that may result in death or serious personal injury if the corresponding measures are not taken.
 Danger!	Danger of personal injury through a general source of danger Reference to an imminent danger that may result in death or serious personal injury if the corresponding measures are not taken.
 Stop!	Danger of property damage Reference to a possible danger that may result in property damage if the corresponding measures are not taken.

Application notes

Pictograph and signal word	Meaning
 Note!	Important note to ensure troublefree operation
 Tip!	Useful tip for simple handling
	Reference to another documentation

3 Technical data

3.1 Product description

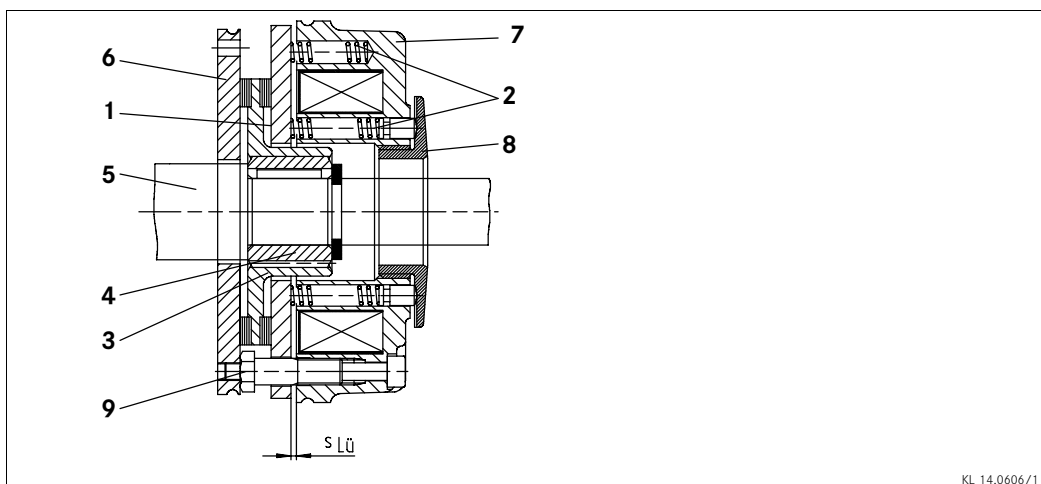

KL 14.0606/1

Fig. 1 Design of the spring-applied brake INTORQ BFK458: basic module E (complete stator) + rotor + hub + flange

- | | | | | | |
|---|---------------------|---|--------|-----------|------------------|
| 1 | Armature plate | 4 | Hub | 7 | Stator |
| 2 | Compression springs | 5 | Shaft | 8 | Adjuster nut |
| 3 | Rotor | 6 | Flange | 9 | Threaded sleeves |
| | | | | s_{air} | Air gap |

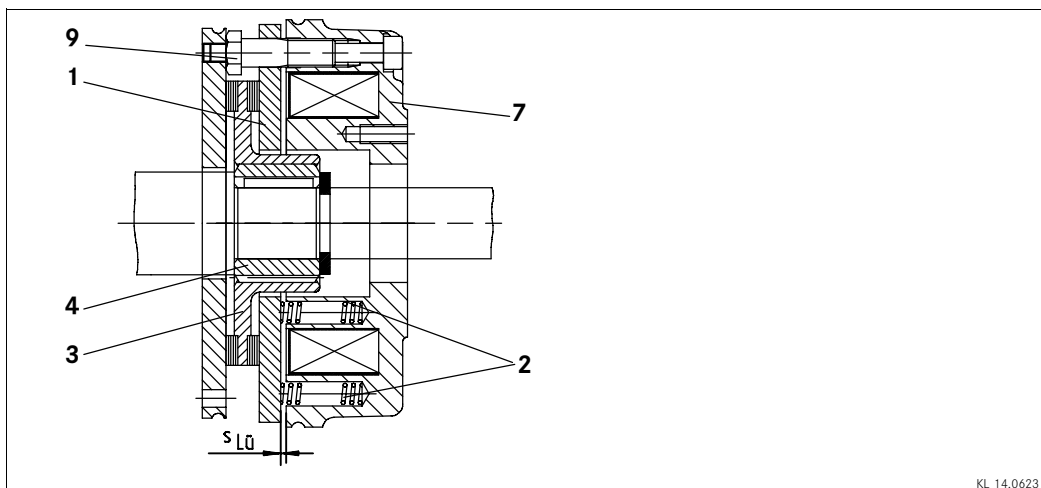

KL 14.0623

Fig. 2 Design of the spring-applied brake INTORQ BFK458: basic module N (complete stator) + rotor + hub + flange

- | | | | | | |
|---|-----------------|---|------------------|-----------|---------|
| 1 | Armature plate | 4 | Hub | s_{air} | Air gap |
| 2 | Pressure spring | 7 | Stator | | |
| 3 | Rotor | 9 | Threaded sleeves | | |

3 Technical data

3.1.1 General information

The spring-applied brake INTORQ BFK458-□□ is a single-disk brake with two friction surfaces. Several compression springs (2) create the braking torque by friction locking. The brake is released electromagnetically.

The spring-applied brake is designed for the conversion of mechanical work and kinetic energy into heat. For operating speed, see chapter 3.3 Rated data. Due to the static brake torque, the brake can hold loads without speed difference. Emergency braking is possible at high speed, see chapter 3.3 Rated data. The more friction work, the higher the wear.

3.1.2 Braking

During braking, the rotor (3), which is axially movable on the hub (4), is pressed against the friction surface - via the armature plate (1) - by means of the inner and outer springs (2). The asbestos-free friction linings ensure a high brake torque with low wear. The brake torque is transmitted between hub (4) and rotor (3) via the splines.

3.1.3 Brake release

In braked state, there is an air gap " s_{air} " between stator (7) and armature plate (1). To release the brake, the stator coil (7) is excited with the DC voltage provided. The magnetic force generated attracts the armature plate (1) towards the stator (7) against the spring force. The rotor (3) is then released and can rotate freely.

3.1.4 Reducing the brake torque

For basic module E (adjustable), the spring force and thus the brake torque can be reduced by unscrewing the adjuster nut (8) (📖 40).

3.1.5 Manual release (optional)

The manual release is optionally available for short-term releases when no voltage is applied. The manual release can be retrofitted.

3.1.6 Microswitch (optional)

The manufacturer offers the microswitch for air-gap or wear monitoring. The user must provide the corresponding electrical connection (📖 32 following).

When air-gap monitoring, the motor does not start before the brake has been released. With this set-up, all possible faults are monitored. For example, in the event of defective rectifiers, interrupted connection cables, defective coils, or excessive air gaps the motor will not start.

When checking the wear, no current will be applied to the brake and the motor if the air gap is too large.

3 Technical data

3.1.7 Encapsulated design (optional)

This design not only avoids the penetration of spray water and dust, but also the spreading of abrasion particles outside the brake. This is achieved by:

- a cover seal over the armature plate and rotor,
- a cover in the adjuster nut,
- a shaft seal in the adjuster nut for continuous shafts (option).

3.2 Brake torques



Stop!

Please observe that engagement times and disengagement times change depending on the brake torque.

Size	06	08	10	12	14	16	18	20	25
Rated torques [Nm], referring to the relative speed $\Delta n = 100 \text{ min}^{-1}$								80 E	
	1,5 E	3,5 N/E			25 N/E	35 N/E	65 N/E	115 N/E	175 N/E
	2 N/E	4 E	7 N/E	14 N/E	35 N	45 N/E	80 N/E	145 N/E	220
	2,5 N/E	5 N/E	9 N/E	18 N/E	40 N/E	55 N/E	100 N/E	170 N/E	265 N/E
	3 N/E	6 N/E	11 N/E	23 N/E	45 N/E	60 N/E	115 N/E	200 N/E	300 N/E
	3,5 N/E	7 N/E	14 N/E	27 N/E	55 N/E	70 N/E	130 N/E	230 N/E	350 N/E
	4 N/E	8 N/E	16 N/E	32 N/E	60 N/E	80 N/E	150 N/E	260 N/E	400 N/E
	4,5 N/E	9 N/E	18 N/E	36 N/E	65 N/E	90 N/E	165 N/E	290 N/E	445 N/E
	5 E	10 E	20 E	40 E	75 N/E	100 N/E	185 N/E	315 N/E	490 N/E
	5,5 E	11 E	23 N/E	46 N/E	80 N/E	105 N/E	200 N/E	345 N/E	530 N/E
6 N/E	12				125 N/E	235 N/E	400 N/E	600 N/E	

Tab. 1 N.....Brake torque for module N (without adjuster nut)
E.....Brake torque for module E (with adjuster nut)

- Holding brake with emergency stop operation ($s_{L\ddot{u}max.}$ approx. $1.5 \times s_{L\ddot{u}rated}$)
- Service brake ($s_{L\ddot{u}max.}$ approx. $2.5 \times s_{L\ddot{u}rated}$)
- Standard brake torque

3 Technical data

3.2.1 Basic module E, brake torque reduction

For basic module E, the brake torque can be reduced by means of the adjuster nut in the stator. The adjuster nut may only be screwed out up to the maximum projection "h_{E_{max}}". (□ 14).

Size	06	08	10	12	14	16	18	20	25
Torque reduction per lock-in position [Nm]	0,2	0,35	0,8	1,3	1,7	1,6	3,6	5,6	6,2

Tab. 2

3.2.2 Brake torques depending on the speed and permissible limit speeds

Type	Rated brake torque at $\Delta n = 100$ r/min [%]	Brake torque at Δn_0 [r/min] [%]			max. speed Δn_{0max} with horizontal mounting position [r/min]
		1500	3000	maximum	
INTORQ BFK458-06	100	87	80	74	6000
INTORQ BFK458-08		85	78	73	5000
INTORQ BFK458-10		83	76		4000
INTORQ BFK458-12		81	74	3600	
INTORQ BFK458-14		80	73		72
INTORQ BFK458-16		79	72		70
INTORQ BFK458-18		77	70		68
INTORQ BFK458-20		75	68		66
INTORQ BFK458-25		73	66	3000	

Tab. 3 Brake torques depending on the speed and permissible limit speeds

3 Technical data

3.3 Rated data

Type	$s_{L\text{ürated}}$ +0.1 mm -0.05 mm	$s_{L\text{ümax.}}$ service brake	$s_{L\text{ümax.}}$ holding brake	max. adjustment, permissible wear	Rotor thickness		Excess of the adjuster nut $h_{E\text{max.}}$
	[mm]	[mm]	[mm]	[mm]	min. ¹⁾ [mm]	max. [mm]	[mm]
INTORQ BFK458-06	0,2	0,5	0,3	1,5	4,5	6,0	4,5
INTORQ BFK458-08					5,5	7,0	
INTORQ BFK458-10					7,5	9,0	
INTORQ BFK458-12	0,3	0,75	0,45	2,0	8,0	10,0	9,5
INTORQ BFK458-14				2,5	7,5		11
INTORQ BFK458-16				3,5	8,0	11,5	10
INTORQ BFK458-18				3,0	10,0	13,0	15
INTORQ BFK458-20	0,4	1,0	0,6	4,0	12,0	16,0	17
INTORQ BFK458-25	0,5	1,25	0,75	4,5	15,5	20,0	19,5

Type	Pitch circle		Screws for flange installation DIN912 10.9	Minimum depth of the clearing holes (installation flange)	Tightening torque		Weight of complete stator
	Ø[mm]	Thread	²⁾	[mm]	Screws [Nm]	Complete lever [Nm]	[kg]
INTORQ BFK458-06	72	3 x M4	3 x M4	0,5	3,0	2,8	0,75
INTORQ BFK458-08	90	3 x M5	3 x M5	1	5,9		1,2
INTORQ BFK458-10	112	3 x M6	3 x M6	2	10,1	4,8	2,1
INTORQ BFK458-12	132	3 x M6	3 x M6	3			3,5
INTORQ BFK458-14	145	3 x M8	3 x M8	1,5	24,6	12	5,2
INTORQ BFK458-16	170			0,5			7,9
INTORQ BFK458-18	196	6 x M8	4 x M8 ³⁾	0,8			23
INTORQ BFK458-20	230	6 x M10	4 x M10 ³⁾	2,1	19,3		
INTORQ BFK458-25	278		6 x M10	6 x M10	5	48	40

Tab. 4 Rated data - INTORQ BFK458spring-applied brake

- 1) The friction lining is designed such that the brake can be adjusted at least 5 times.
- 2) The screw length depends on the material and the thickness of the customer's mounting place.
- 3) The thread in the threading surface is offset by 30° in reference to the center axle of the manual release lever.

3 Technical data

Type	Electrical power $P_{20}^{1)}$	Rated current I_N	Release voltage/holding voltage U	Coil resistance $R_{20} \pm 8\%$
	[W]		[V]	
INTORQ BFK458-06	20	0,83	24	20
		0,21	96	460,8
		0,194	103	530,5
		0,114	170	1445
		0,111	180	1620
		0,105	190	1805
		0,098	205	2101
INTORQ BFK458-08	25	1,04	24	23
		0,26	89	368
		0,242	103	424,4
		0,147	170	1156
		0,138	180	1296
		0,131	190	1444
		0,121	205	1681
INTORQ BFK458-10	30	1,25	24	19,2
	31	0,322	96	297,3
	32	0,31	103	331,5
	30	0,176	170	963,3
	32	0,177	180	1013
	30	0,157	190	1203
	33	0,160	205	1273
INTORQ BFK458-12	40	1,66	24	14,4
		0,41	96	230,4
		0,388	103	265,2
		0,235	170	722,5
		0,222	180	810
		0,210	190	902,5
		0,195	205	1051
INTORQ BFK458-14	50	2,08	24	11,5
		0,52	96	184,3
	53	0,514	103	200,2
	50	0,294	170	578
	53	0,294	180	611,3
	50	0,263	190	722
	53	0,258	205	792,9
INTORQ BFK458-16	55	2,29	24	10,5
		0,573	96	167,6
	56	0,543	103	189,5
	55	0,323	170	525,5
		0,305	180	589,1
	60	0,315	190	601,7
	56	0,292	205	750,5

3 Technical data

Type	Electrical power P_{20} ¹⁾	Rated current I_N	Release voltage/holding voltage U	Coil resistance $R_{20} \pm 8\%$
	[W]		[V]	[Ω]
INTORQ BFK458-18	85	3,54	24	6,8
		0,885	96	108,4
		0,825	103	124,8
		0,5	170	340
		0,472	180	387,2
		0,447	190	424,7
		0,414	205	494,4
INTORQ BFK458-20	100	4,16	24	5,76
		1,04	96	92,2
		0,970	103	106,1
		0,588	170	289
		0,55	180	324
		0,487	205	420,3
	110	0,578	190	328,2
INTORQ BFK458-25	110	4,58	24	5,24
		1,14	96	83,8
		1,06	103	96,5
		0,647	170	262,7
		0,611	180	294,6
		0,578	190	328,2
		0,536	205	382,1

Tab. 5 Coil power of INTORQ BFK468

¹⁾ Coil power at 20°C

3 Technical data



3.4 Operating times

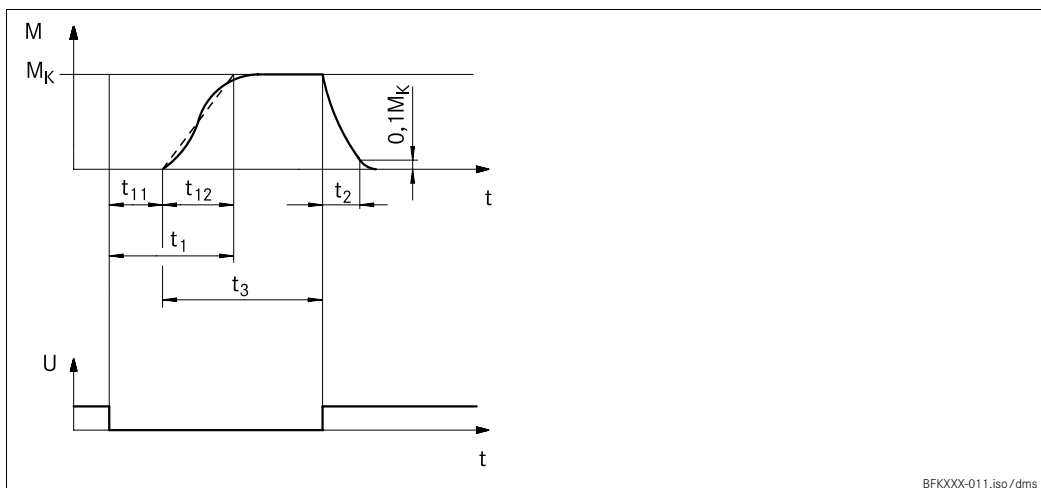

Fig. 3 Operating times of the INTORQ spring-applied brakes

- t_1 Engagement time
- t_2 Disengagement time (up to $M = 0.1 M_r$)
- t_3 Slipping time
- t_{11} Reaction delay during engagement
- t_{12} Rise time of the brake torque
- m Brake torque
- U Excitation

Type	Rated brake torque at $\Delta n = 100$ r/min M_r 1) [Nm]	Max. permissible friction work per operation only Q_E [J]	Transition frequency $s_{h\ddot{u}}$ [h ⁻¹]	Operating times [ms] at $s_{L\ddot{u}rated}$ and $0,7 I_N$			
				Engaging DC-switching			Disengagement t_2
				t_{11}	t_{12}	t_1	
INTORQ BFK458-06	4	3000	79	15	13	28	45
INTORQ BFK458-08	8	7500	50	15	16	31	57
INTORQ BFK458-10	16	12000	40	28	19	47	76
INTORQ BFK458-12	32	24000	30	28	25	53	115
INTORQ BFK458-14	60	30000	28	17	25	42	210
INTORQ BFK458-16	80	36000	27	27	30	57	220
INTORQ BFK458-18	150	60000	20	33	45	78	270
INTORQ BFK458-20	260	80000	19	65	100	165	340
INTORQ BFK458-25	400	120000	15	110	120	230	390

Tab. 6 Friction work - operating frequency - operating times

1) Minimum brake torque when all components are run in

The transition from the state without brake torque to the steady brake torque is not without delay. The engagement times are valid for switching on the DC side with an induction voltage of approx. 5 to 10 times nominal voltage. The chart shows the delay during engagement t_{11} , the rise time of the brake torque t_{12} and the engagement time $t_1 = t_{11} + t_{12}$, as well as the disengagement time t_2 .

Disengagement time

The disengagement time is not influenced by DC or AC switching operations. It can only be shortened by special equipment for fast-response excitation or overexcitation.

3 Technical data

Engagement time

With switching on the AC side, the engagement times are prolonged approximately by the factor 10, for connection see page 32.

Spark suppressors for the rated voltages, which are to be connected in parallel to the contact are available for engagement on the DC side. If this is not admissible for safety reasons, e.g. with hoists and lifts, the spark suppressor can also be connected in parallel to the brake coil, for connection see page 33.

A reduction of the brake torque via the adjuster nut prolongs the engagement time and reduces the disengagement time. If the prolongation is too long, an anti-magnetic plate - to be assembled between stator and armature plate - is available. The plate reduces the engagement time and prolongs the disengagement time.

3 Technical data

3.5 Operating frequency / friction work

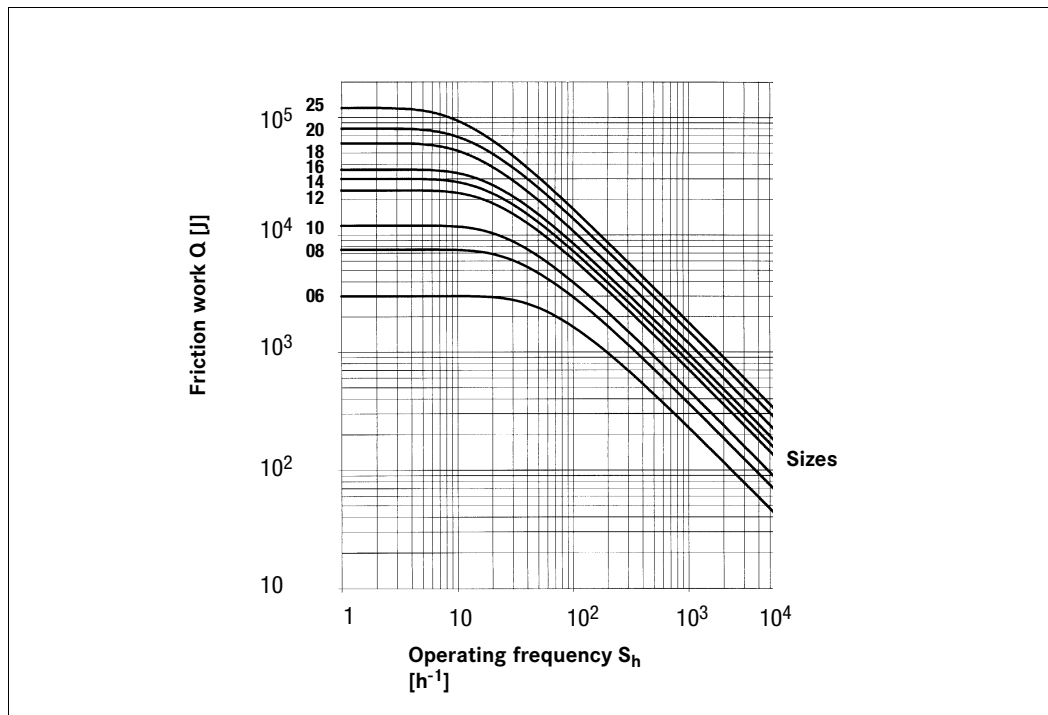

Fig. 4 Friction work as a function of the operating frequency

$$S_{fperm} = \frac{-S_{ff}}{\ln\left(1 - \frac{Q}{Q_E}\right)} \quad Q_{perm} = Q_E \left(1 - e^{-\frac{S_{ff}}{S_f}}\right)$$

The permissible operating frequency " S_{hperm} " depends on the friction work " Q " (see Fig. 4). An operating frequency of " S_h " results in the permissible friction work " Q_{perm} ".

With high speed and friction work, the wear increases strongly, because very high temperatures occur at the friction faces for a short time.

3 Technical data

3.6 Emission

Electromagnetic compatibility

**Note!**

The user must ensure compliance with EMC Directive 2004/108/EC using appropriate controls and switching devices.

If an INTORQ rectifier is used for the DC switching of an INTORQ spring-applied brake and if the operating frequency exceeds five switching operations per minute, the use of a mains filter is required. If the INTORQ spring-applied brake uses a rectifier of another manufacturer for the switching, it may become necessary to connect a spark suppressor in parallel with the AC voltage. Spark suppressor according to coil voltage on request.

Heat

Since the brake converts kinetic energy as well as mechanical and electrical energy into heat, the surface temperature varies considerably, depending on the operating conditions and possible heat dissipation. Under unfavourable conditions, the surface temperature can reach 130°C.

Noises

The switching noises during engagement and disengagement depend on the air gap "s_{air}" and the brake size.

Depending on the natural oscillation after installation, operating conditions and state of the friction faces, the brake may squeak during braking.

Others

The abrasion of the friction parts produces dust.

In case of high load, the friction face will become so hot that odours may occur.

4 Mechanical installation



STOP **Stop!**
Toothed hub and screws must not be lubricated with grease or oil!

4.1 Necessary tools

Type	Torque wrench Insertion for hexagon socket screws		Spanner wrench size [mm]			Hook wrench DIN 1810 design A	Box spanner for flange installation, outside
	Measuring range [Nm]	Wrench size [mm]	Threaded sleeves	Manual release Nuts/bolts	2kt lever	Diameter [mm]	Wrench size [mm]
INTORQ BFK458-06	1 to 12	3 x 1/4" square	8	7 / 5,5	7	45 - 55	7 x 1/2" square
INTORQ BFK458-08		4 x 1/4" square	9	10 / 7		52 - 55	8 x 1/2" square
INTORQ BFK458-10		5 x 1/4" square	12			68 - 75	10 x 1/2" square
INTORQ BFK458-12			80 - 90				
INTORQ BFK458-14	20 to 100	6 x 1/2" square	15	12 / 8	9	95 - 100	13 x 1/2" square
INTORQ BFK458-16				-	10	110 - 115	
INTORQ BFK458-18					/ 10	12	135 - 145
INTORQ BFK458-20		14	17	155 - 165		17 x 1/2" square	
INTORQ BFK458-25							

* for flange mounting insertion with journal guide

Feeler gauge	Caliper gauge	Multimeter

4 Mechanical installation

4.2 Mounting

4.2.1 Preparation

1. Unpack spring-applied brake.
2. Check for completeness.
3. Check nameplate data, especially rated voltage.

4.3 Installation

When you have ordered a version with manual release or flange, attach these units first.

4.3.1 Installation of the hub onto the shaft

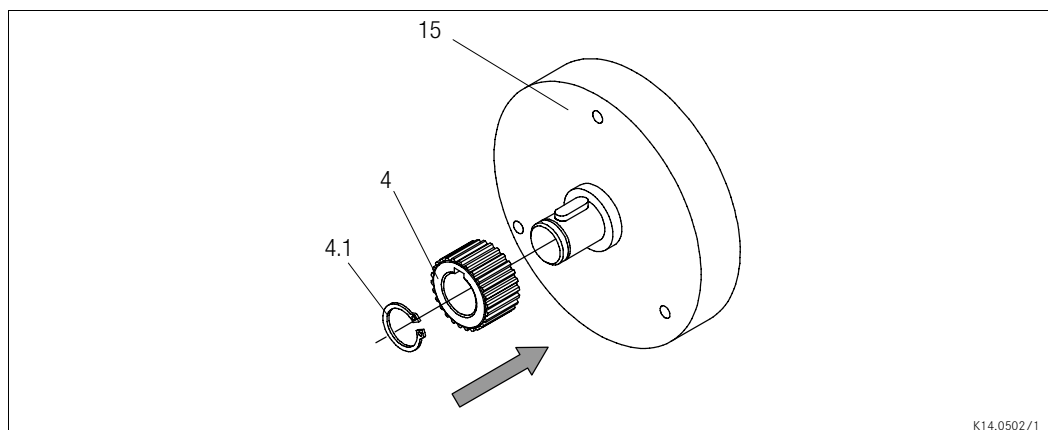

Fig. 5 Mounting the hub on the shaft

4 Hub

4.1 Circlip

15 End shield

1. Press the hub (4) on the shaft.
2. Secure the hub against axial displacement, e.g. with a circlip (4.1).



Stop!

In reverse operation, it is recommended to additionally glue the hub to the shaft, (e.g. using Delo-ML 5328)!

4 Mechanical installation

4.3.2 Installation of the brake



Stop!

- When dimensioning the thread depth in the endshield, consider the permissible wear (chapter 3.3).
- Check the condition of the endshield (15). It must be free of oil and grease.

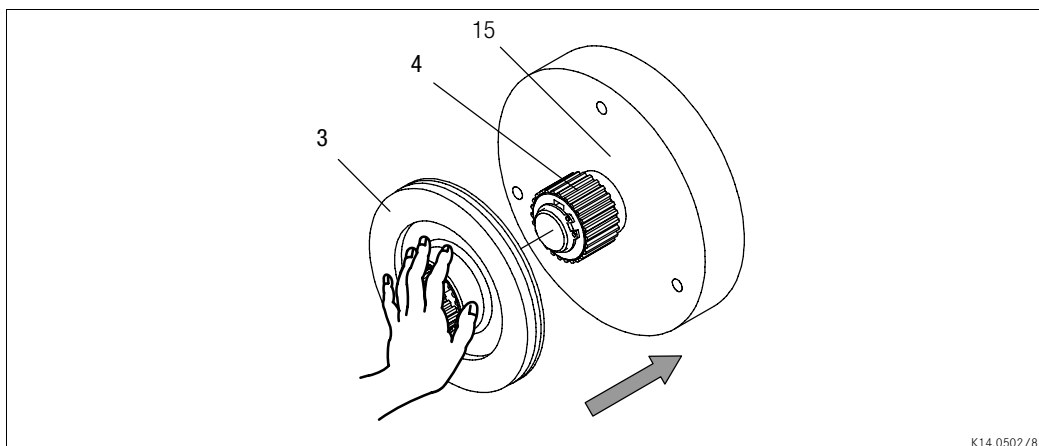

Fig. 6 Assembly of the rotor

3 Rotor

4 Hub

15 Endshield

1. Push the rotor (3) onto the hub (4) and check whether it can be moved by hand (Fig. 6).



Stop!

Please note the following for the version "brake with shaft seal in adjuster nut":

2. Lightly lubricate the lip of the shaft seal with grease.
3. When assembling the stator (7) push the shaft seal carefully over the shaft.
 - The shaft should be located concentrically to the shaft seal.

4 Mechanical installation

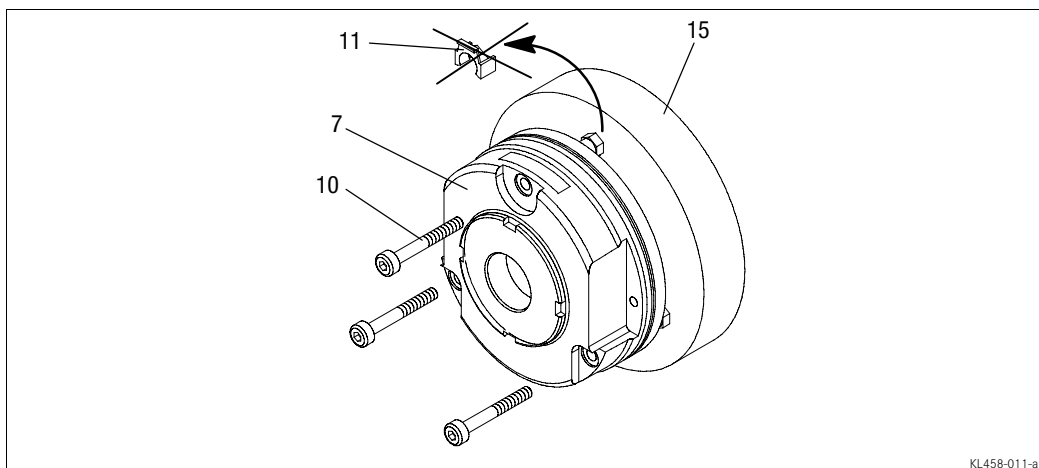

Fig. 7 Assembly of the spring-applied brake

7 Complete stator	11 Clip
10 Allen screw	15 Endshield

- Screw the complete stator (7) onto the endshield (15) using the screws (10). (Fig. 7).
- Remove the clips (11) (throw away; Fig. 7).

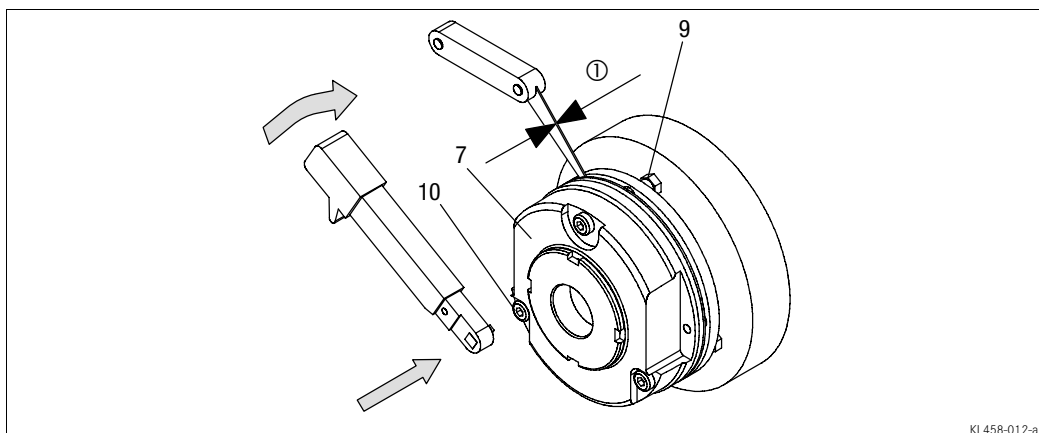

Fig. 8 Torque adjustment

7 Stator	9 Threaded sleeve	① $s_{Lürated}$
10 Allen screw		

- Tighten the screws (10) evenly (for torques see table chapter 3.3 and Fig. 8).
- Check the air gap " $s_{Lürated}$ " near the bolts (10) by means of the thickness gauge (" $s_{Lürated}$ " see table chapter 3.3 and Fig. 8).

4 Mechanical installation

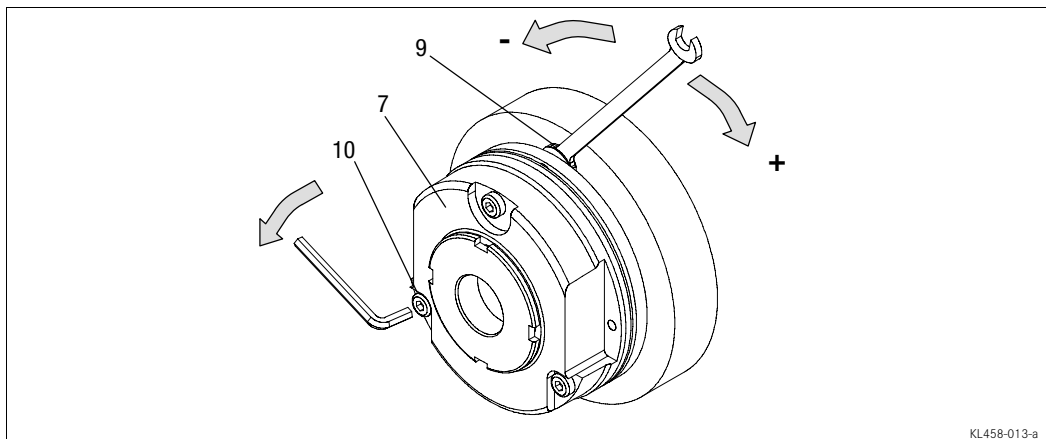

Fig. 9 Air gap adjustment

- 7 Stator
9 Threaded sleeve
10 Allen screw

If the air gap (s. 3.3), " $s_{Lü rated}$ " deviates too much, adjust:

8. Unbolt screws (10).



Note!

Correctly set the air gap using every second screw (10)/threaded sleeve (9)! Screw the other three threaded sleeves such into the stator that they do not touch the flange/the endshield. Then do the same once again using the other three screws (10).

9. Slightly turn threaded sleeves (9) using a spanner.
- If the air gap is too large, screw them into the complete stator (7).
 - If the air gap is too small, screw them out of the complete stator (7).
 - $1/6$ turn changes the width of the air gap by approx. 0.15mm.
10. Tighten the screws (10) (for torques see chapter 3.3).
11. Check air gap again and, if necessary, repeat the adjustment.

4 Mechanical installation

4.3.3 Assembly of the friction plate, sizes 06 to 16

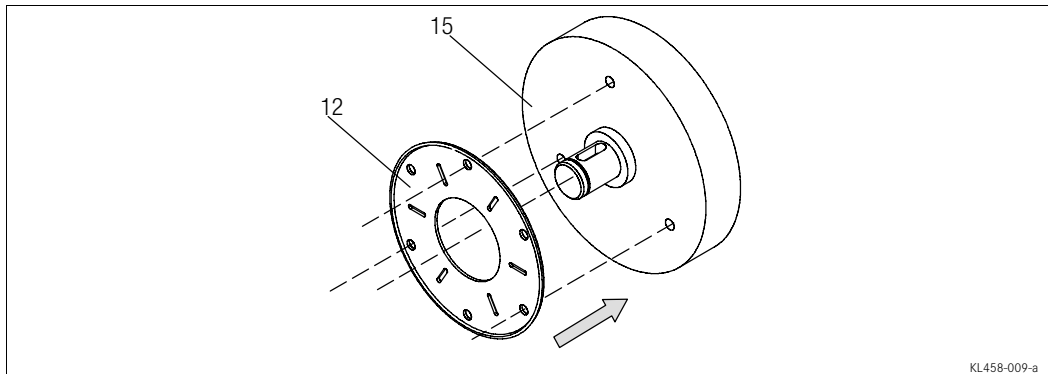

Fig. 10 Mounting the friction plate

12 Friction plate

15 End shield

1. Hold the friction plate (12) against the end shield (15).
2. Check pitch circle and fastening bore hole threads.



Note!

The lip edging must remain visible!

4.3.4 Assembly of the flange

The flange (6) can be screwed to the end shield (15) on the outer pitch circle (screw dimensioning is given in chapter 3.3).

Mounting the flange with additional screws



Stop!

- Clearing holes for the screws in the end shield must be behind the threaded screw drill-holes in the flange. Without the clearing holes, minimal rotor thickness cannot be utilised. The screws must not press against the end shield. (See chapter 3.3 for clearing hole depth)
- For sizes 18 and 20, the fastening surface threading must be angled at 30° to the centre axis to the manual release lever.

4 Mechanical installation

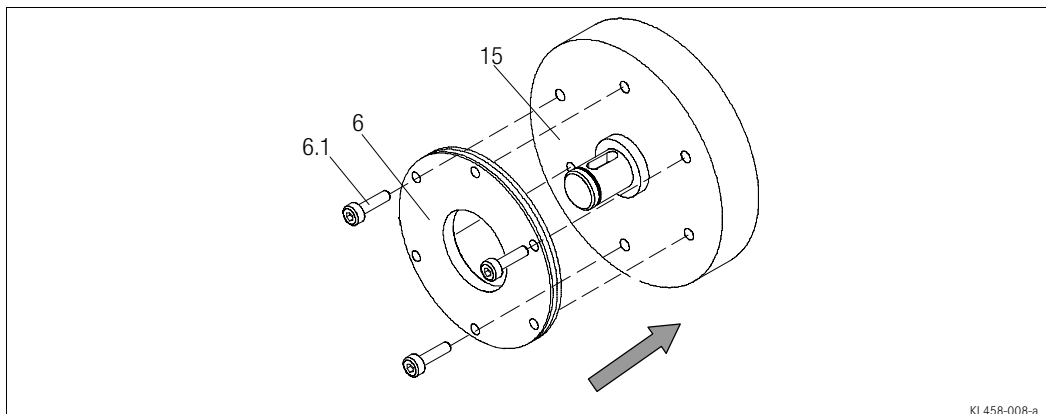

Fig. 11 Mounting the flange

6	Flange	15	End shield
6.1	Set of fastening screws		

1. Hold the flange (6) against the end shield (15) and check the pitch circle and retaining screw drill hole threading.
2. Fasten the flange (6) with the screws (6.1) to the end shield (15).
3. Tighten the screws (6.1) evenly (see chapter 3.3 for the correct tightening torques).
4. Check screw head height. The height must not exceed the minimal rotor thickness. We recommend using DIN 6912 screws (dimensions are given in chapter 3.3).

Mounting the flange without additional screws



Stop!

Consider the permissible wear when dimensioning the depth of the thread in the end shield (see chapter 3.3).

1. Hold the flange (6) against the end shield (15) and check the pitch circle and retaining screw drill hole threading.
2. Install the brake using the set of screws supplied (see chapters 4.3.2 and 7.4).

4 Mechanical installation

4.3.5 Assembly of the cover seal

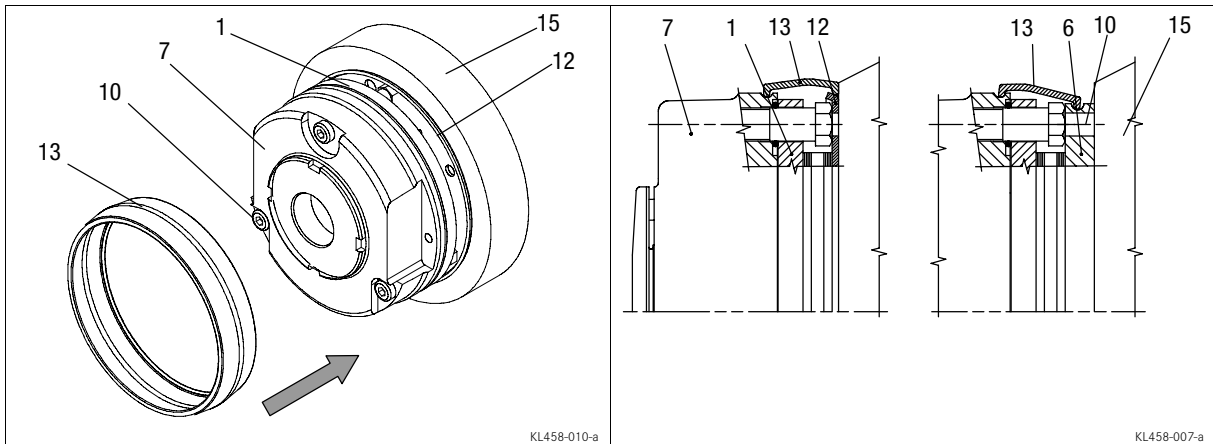

Fig. 12 Assembly of the cover seal

1	Armature plate	10	Allen screw	15	Endshield
6	Flange	12	Friction plate		
7	Stator	13	Cover seal		

1. Pull the cable through the seal ring (5).
2. Then push the seal ring (5) over the stator (1).
3. Press the lips of the seal ring (5) into the groove on the stator (1) and flange (6).
 - If a friction plate (7) is used, the lip must be pulled over the edging.

4 Mechanical installation



4.3.6 Assembly of the manual release

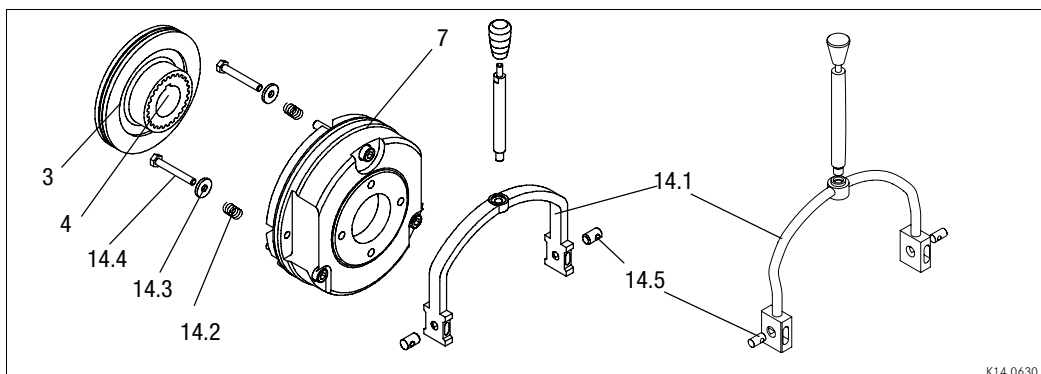
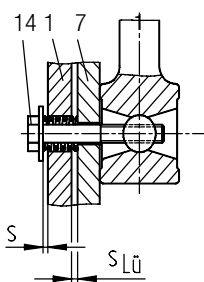

Fig. 13 Assembly of the manual release BFK458

1. Insert the compression springs (14.2) into the bore holes of the armature plate (1).
2. Push the bolts (14.5) into the bore holes of the shackle (6.1).
3. Push the hexagon head cap screw (14.4) through the compression spring (6.2) in the armature plate (1) and the bore hole in the stator (7).
4. Screw the hexagon head cap screw (14.4) into the bolts (14.5) in the shackle (14.1).
5. Tighten hexagon screw (14.4) until armature plate (1) moves towards stator (7).
6. Remove the clips (11) (throw away).
7. Adjust gap "s" and "s_{Lü}" using the hexagon head cap screw (14.4), (values for "s" and "s_{Lü}" see Tab. 7).

Type
INTORQ BFK458-06
INTORQ BFK458-08
INTORQ BFK458-10
INTORQ BFK458-12
INTORQ BFK458-14
INTORQ BFK458-16
INTORQ BFK458-18
INTORQ BFK458-20
INTORQ BFK458-25



s _{Lü} (mm)	s + ^{0.1} (mm)	s + s _{Lü} (mm)
0,2	1	1,2
0,3	1,5	1,8
0,4	2	2,4
0,5	2,5	3

Tab. 7 Adjustment setting for manual release

Stop!

Dimension "s" must be observed! Check air gap "s_{Lü}".

5 Electrical installation

5.1 Bridge/half-wave rectifiers

BEG-561-□□□ - □□□

Bridge/half-wave rectifiers are used for the supply of electromagnetic spring-applied DC brakes which have been released for operation with such rectifiers. Any other use is only permitted with the explicit written approval of INTORQ.

After a defined overexcitation time, the bridge/half-wave rectifiers change from bridge rectification to half-wave rectification. Depending on the dimensioning of the load, the switching performance can thus be improved or the power can be derated.

Terminals 3 and 4 are in the DC circuit of the brake. The induction voltage peak for DC switching (see circuit diagram "Reduced switch-off times") is limited by an integrated overvoltage protection at terminals 5 and 6.

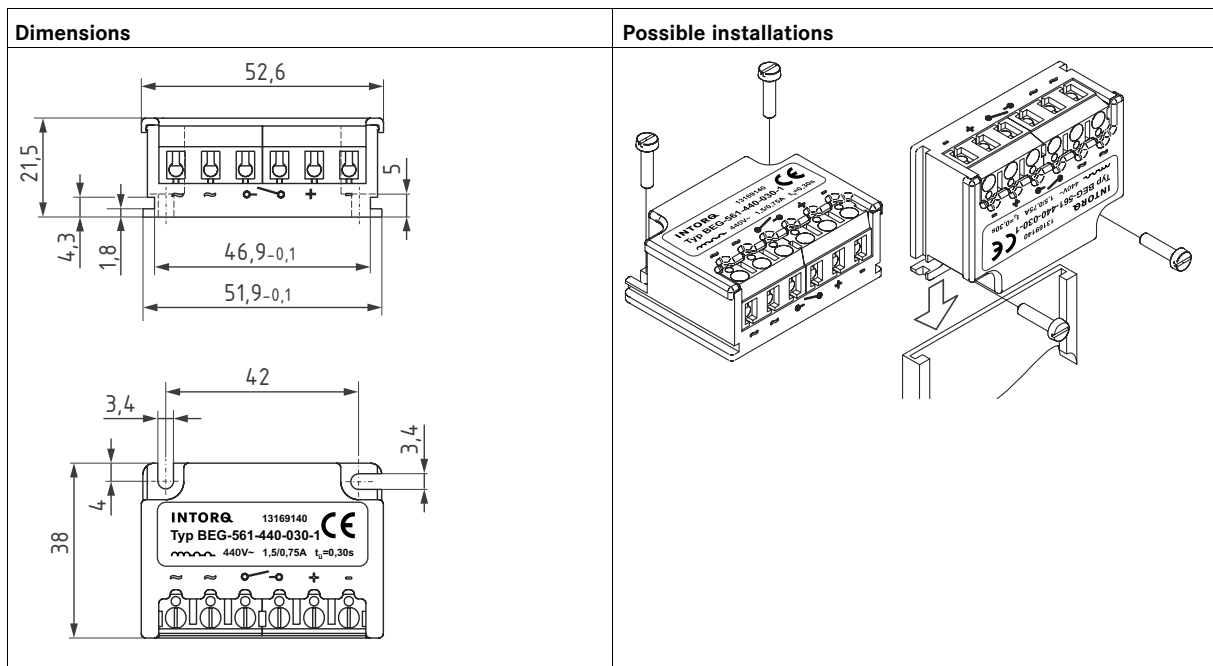

Fig. 14 Dimensions and possible installations of bridge/half-wave rectifier

5.1.1 Technical data

Rectifier type	Bridge/half-wave rectifier
Output voltage for bridge rectification	$0.9 \times U_1$
Output voltage for half-wave rectification	$0.45 \times U_1$
Ambient temperature (storage/operation) [C°]	-25 ... +70

5 Electrical installation

Type	Input voltage U_1 (40 Hz ... 60 Hz)			Max. current I_{max}		Overexcitation time t_o ($\pm 20\%$)		
	min. [V ~]	rated [V ~]	max. [V ~]	bridge [A]	half-wave [A]	with U_1 min [s]	with U_1 rated [s]	with U_1 max [s]
BEG-561-255-030	160	230	255	3.0	1.5	0.430	0.300	0.270
BEG-561-255-130						1.870	1.300	1.170
BEG-561-440-030-1	230	400	440	1.5	0.75	0.500	0.300	0.270
BEG-561-440-130				3.0	1.5	2.300	1.300	1.200

Tab. 8 Data for bridge/half-wave rectifier type BEG-561
Input voltage U_1 (40 ... 60 Hz)

5.1.2 Reduced switch-off times

When switching on the DC side (reduced switch-off times), switching on the AC side is also required! Otherwise, there will be no overexcitation during power-on.

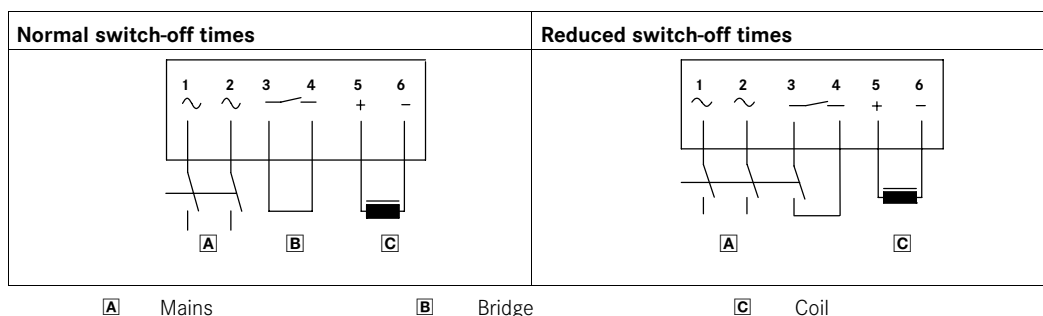

5.1.3 Permissible current load - ambient temperature

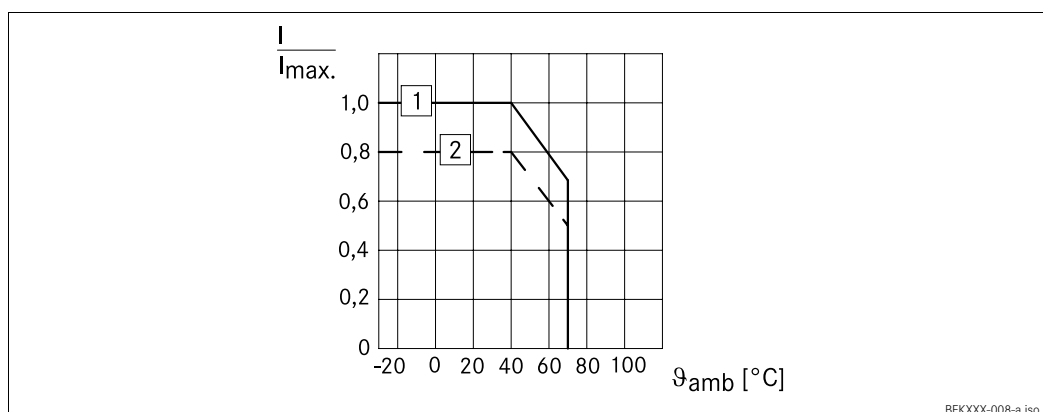

- 1 For screw assembly with metal surface (good heat dissipation)
- 2 For other assembly (e.g. glue)

BFKXXX-008-a.iso

5 Electrical installation

5.1.4 Assignment: Bridge/half-wave rectifier - brake size

Rectifier type	AC voltage [V AC]	Coil voltage release/holding [V DC]	Assigned brake
BEG-561-255-030 BEG-561-255-130	230 ±10%	205 / 103	BFK458-06...25
BEG-561-440-030-1 BEG-561-440-130	400 ±10%	360 / 180	

5.2 Electrical connection



Danger!

- Electrical connection must only be carried out by skilled personnel!
- Connections must only be made when the equipment is de-energised! Danger through unintended starts or electric shocks.



Stop!

- It must be ensured that the supply voltage corresponds to the nameplate data.
- Voltages must be adapted to the local environment!

Circuit proposals

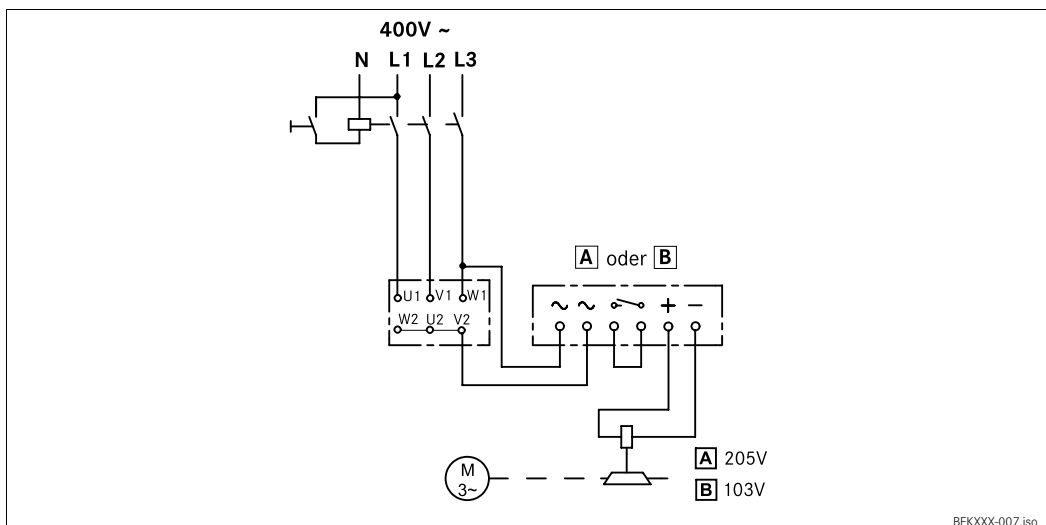

Fig. 15 AC switching, delayed engagement

A Bridge rectifier

B Half-wave rectifier

5 Electrical installation

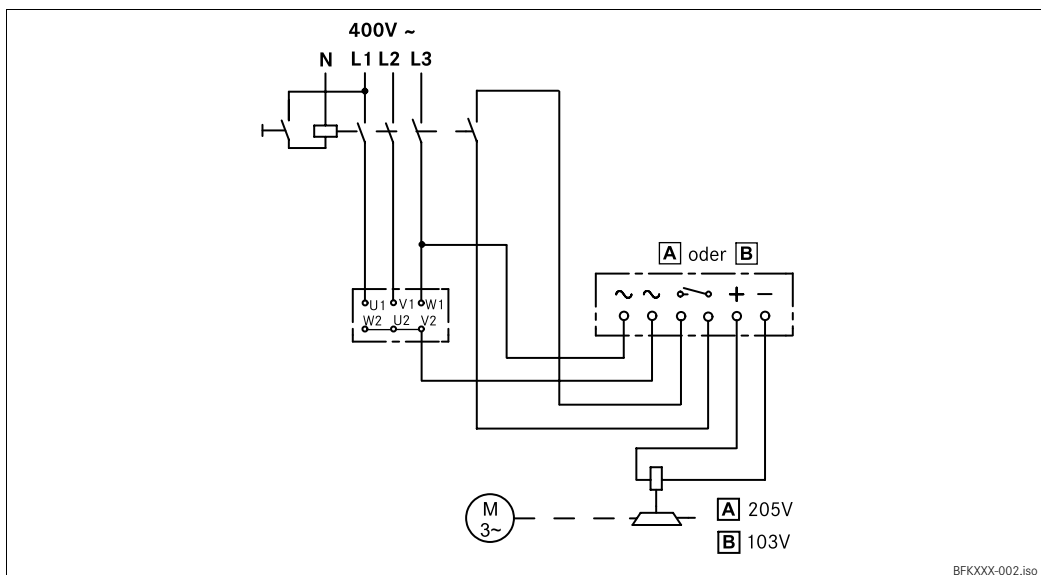

Fig. 16 DC switching, normal engagement

A Bridge rectifier

B Half-wave rectifier

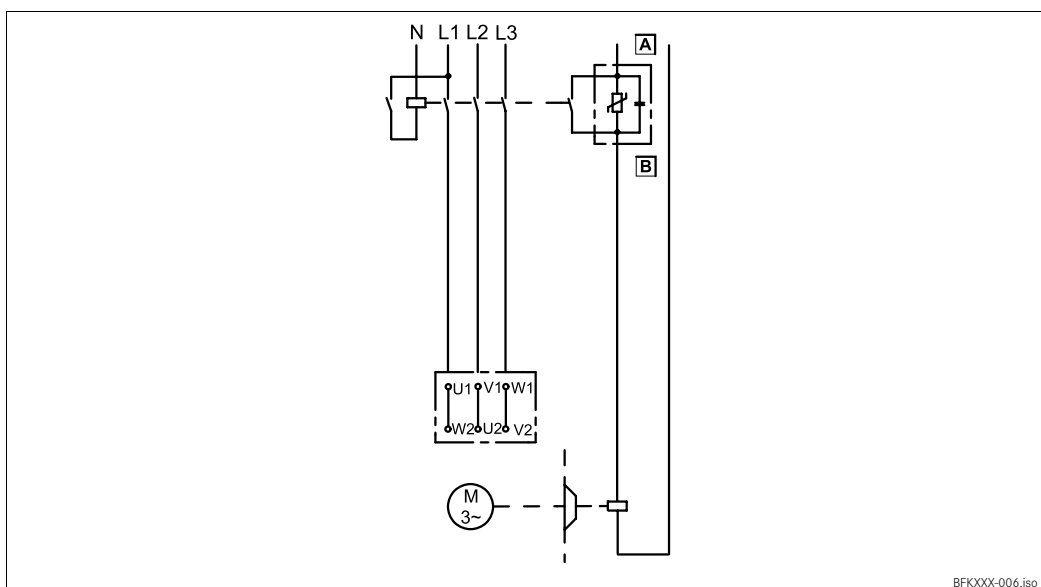

Fig. 17 Separated DC voltage, DC switching

Connection diagram also valid for star connection

A DC voltage (e.g. 24V)

B Spark suppressor



Stop!

For switching on the DC side the brake must be operated with a spark suppressor to avoid impermissible overvoltages.

5 Electrical installation

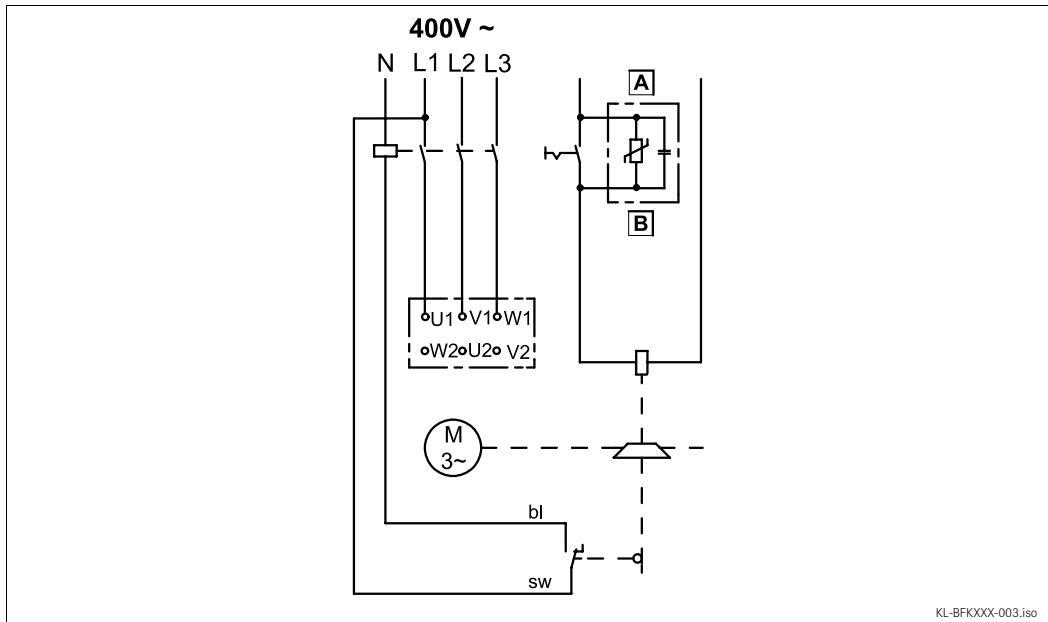

Fig. 18 With microswitch / release check; connection diagram also valid for star connection

- | | | | |
|-----|--------------------------------------|----|-------|
| ▣ A | DC voltage depending on coil voltage | bl | blue |
| ▣ B | Spark suppressor | sw | black |

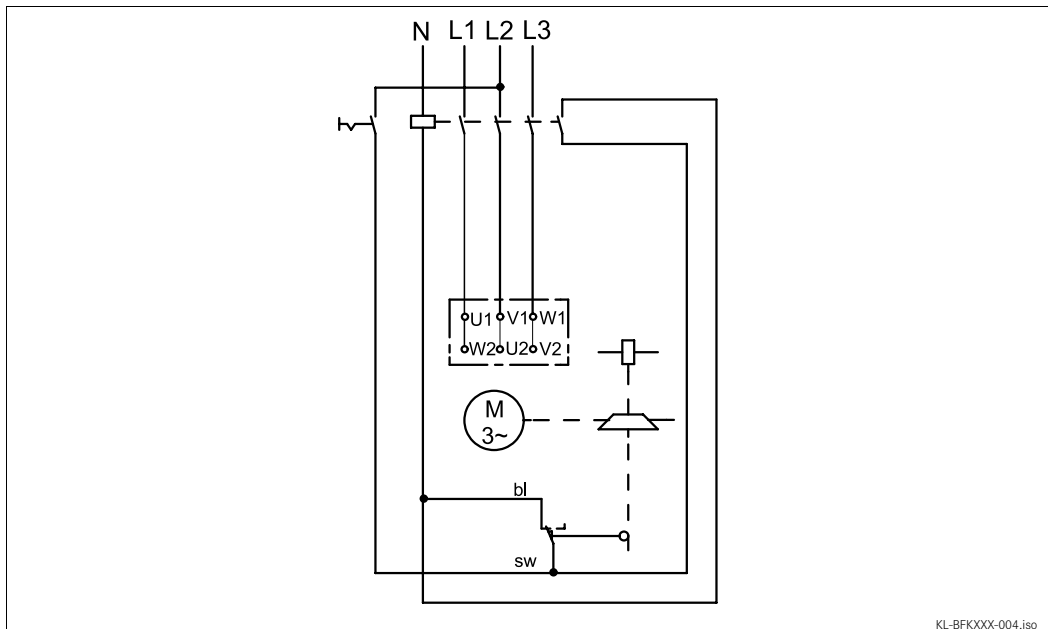

Fig. 19 With microswitch / wear check addition for all circuits; connection diagram also valid for star connection

- | | | | |
|----|------|----|-------|
| bl | blue | sw | black |
|----|------|----|-------|

5 Electrical installation



Tip!

During operation according to Fig. 19 the air gap is only monitored when no voltage is applied to the brake. This makes sense because it is possible that when the current flows only one side of the armature plate is attracted at first. This misalignment may cause a simulation of the maximum air gap and the actuation of the microswitch. If there is no closed contact in parallel to the microswitch contact, motor and brake will be switched off. The microswitch contact is closed again when the armature plate is completely released - the release is repeated again - because of the small difference-contact travel of the microswitch.

To avoid this misinterpretation of the microswitch signal, the signal should only be processed when no voltage is applied to the brake.

1. Mount the rectifier in the terminal box. With motors of the insulation class "H", the rectifier must be mounted in the control cabinet. Permissible ambient temperature for the rectifier -25°C to +70°C.
2. Compare the coil voltage of the stator to the DC voltage of the installed rectifier.
3. Select the suitable circuit diagram. Convert the values to deviating AC voltage, e.g. 380V,

$$380/400 \times 205 = 195V$$
 - Deviations up to 3% are permissible.



Note!

Selection of the rectifier at voltages ≥ 460 V AC  catalogue "Electronic switchgear and accessories" Chapter spark suppressors and rectifiers.

4. Motor and brake must be wired according to the requirements of the engagement time.

6 Commissioning and operation



Danger!

The live connections and the rotating rotor must not be touched.
The drive must not be running when checking the brake.

6.1 Functional test

In the event of failures, refer to the troubleshooting table in chapter 8. If the fault cannot be eliminated, please contact the aftersales service.

6.1.1 Release / voltage check

For brakes without microswitch only



Danger!

The brake must be free of residual torque. The motor must not rotate.



Danger!

Live connections must not be touched.

1. Remove two bridges from the motor terminals. Do **not** switch off the DC brake supply. When connecting the rectifier to the neutral point of the motor, the PE conductor must **also** be connected to this point.
2. Connect the mains supply.
3. Measure the DC voltage at the brake.
 - Compare the DC voltage measured with the voltage specified on the nameplate. A $\pm 10\%$ deviation is permissible.
4. Check air gap "s_{Lü}". It must be zero and the rotor must rotate freely.
5. Switch off the power supply.
6. Bolt bridges to the motor terminals. Remove additional PEN conductor.

6 Commissioning and operation

6.1.2 Microswitch - release check



Danger!

The brake must be free of residual torque. The motor must not rotate.



Danger!

Live connections must not be touched.

Connection diagram: (see page 32)

1. Remove two bridges from the motor terminals.
 - Do not switch off the DC brake supply.
2. The switching contact for the brake must be open.
3. Apply DC voltage to the brake.
4. Measure the AC voltage at the motor terminals. It must be zero.
5. Close the switching contact for the brake.
6. Measure the DC voltage at the brake:
 - The DC voltage measured after the overexcitation time (see bridge/half-wave rectifier, chapter 5.1) must correspond to the holding voltage (see Tab. 8). A 10 % deviation is permissible.
7. Check air gap "s_{LÜ}".
 - It must be zero and the rotor must rotate freely.
8. Open the switching contact for the brake.
9. Check microswitch:

	Contact type	Connection	Brake released	Microswitch closed
	NC contact	black / grey	yes	no
			no	yes
	NO contact	black / blue	yes	yes
			no	no

Tab. 9 Switching status of microswitch

10. Bolt bridges to the motor terminals.

6 Commissioning and operation

6.1.3 Microswitch - wear check



Danger!

The brake must be free of residual torque. The motor must not rotate.



Danger!

Live connections must not be touched.

1. Remove two bridges from the motor terminals. Do not switch off the DC voltage for the brake. When connecting the rectifier to the neutral point of the motor, the PE conductor must also be connected to this point.
2. Set air gap to "s_{Lümax}". See chapter 4.3.2 Step 8-11.
3. Connect the mains supply.
4. Measure the AC voltage at the motor terminals and the DC voltage at the brake. Both must be zero.
5. Disconnect the mains supply.
6. Set air gap to "s_{Lürated}". See chapter 4.3.2 Step 8-11.
7. Connect the mains supply.
8. Measure the AC voltage at the motor terminals. It must be the same as the mains voltage.
9. Measure the DC voltage at the brake.
 - The DC voltage measured after the overexcitation time (see bridge/half-wave rectifier) must be half the voltage indicated on the nameplate. A 10 % deviation is permissible.
10. Check air gap "s_{Lü}". It must be zero and the rotor must rotate freely.
11. Switch off the current for the brake.
12. Bolt bridges to the motor terminals. Remove additional PEN conductor.

6.1.4 Manual release



Stop!

This operational test is to be carried out additionally!



Danger!

The brake must be free of residual torque. The motor must not rotate.

6 Commissioning and operation

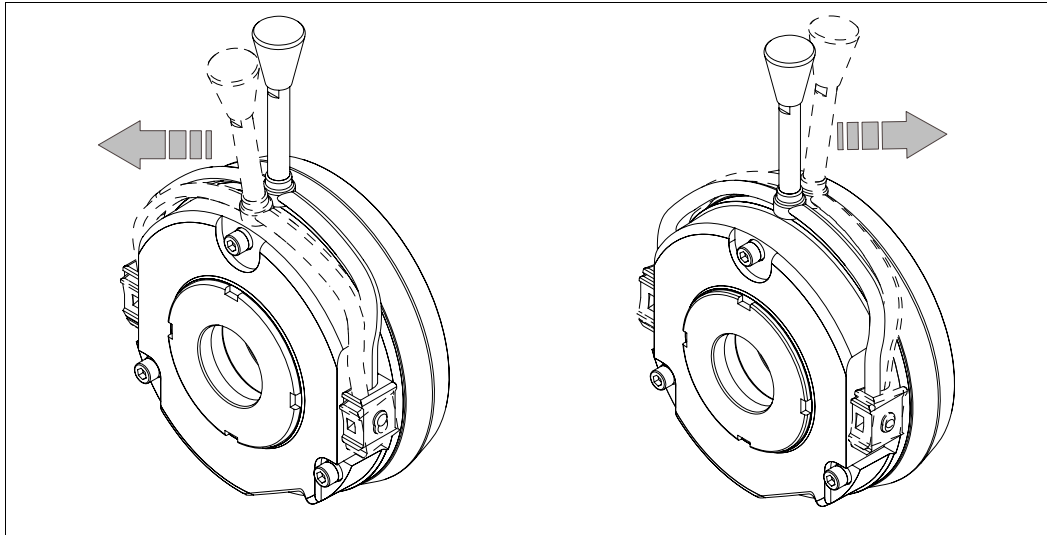

Fig. 20 Turning direction of the lever

1. Pull the lever (Fig. 20) with approx. 150 N until the resistance increases strongly.



Stop!

Additional tools to facilitate brake release are not allowed! (e.g. extension piece)

2. The rotor must rotate freely. A small residual moment is permissible.
3. Release the lever.

6 Commissioning and operation

6.2 Reducing the brake torque

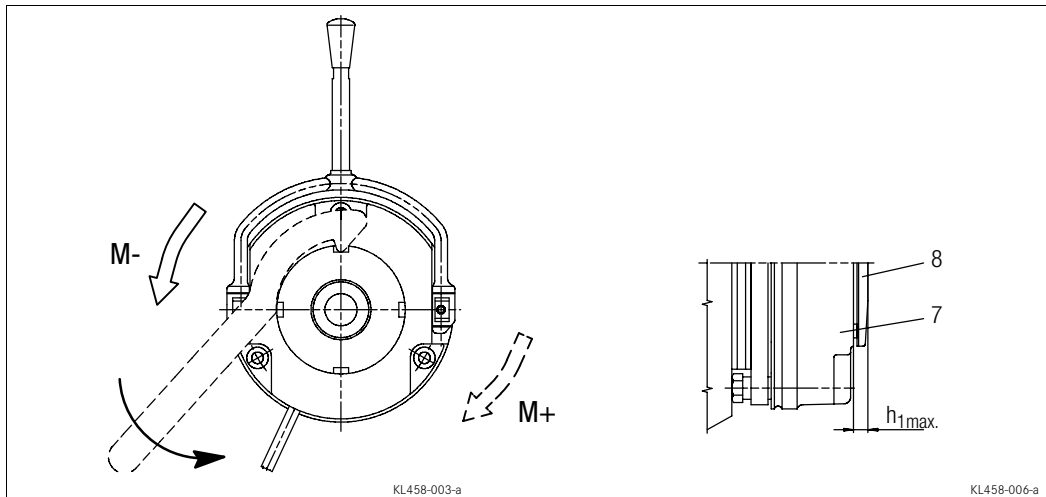

Fig. 21 Reducing the brake torque

7 Stator

8 Adjuster nut

1. Turn the adjuster nut (8) counterclockwise using the hook wrench.
 - Observe the notches. Positions between notches are impermissible. (Values for the brake torque reduction see chapter 3.2.1).
 - The maximum permissible projection " $h_{E_{max}}$ " of the adjuster nut (8) to the stator (7) is to be observed (values for " $h_{E_{max}}$ " see chapter 3.3).



Danger!

The reduction of the brake torque does not increase the maximum permissible air gap " $s_{L_{max}}$ ".

Do not change the manual release setting for models with manual release.

6.3 During operation

- Check the brake regularly during operation. Take special care of:
 - unusual noises and temperatures
 - loose fixing elements
 - the state of the cables.
- In the event of failures, refer to the troubleshooting table in chapter 8. If the fault cannot be eliminated, please contact the aftersales service.

7 Maintenance/repair

7.1 Wear of spring-applied brakes

INTORQ spring-applied brakes are wear-resistant and designed for long maintenance intervals. The friction lining and the mechanical brake components are subject to function-related wear. For safe and trouble-free operation, the brake must be checked and readjusted at regular intervals, and, if necessary, be replaced.

The following table describes different causes of wear and their effects on the components of the spring-applied brake. For calculating the service life of rotor and brake and determining the maintenance intervals to be observed, the relevant factors of influence must be quantified. The most important factors are the friction work, initial speed of braking and the operating frequency. If several of the causes of wear indicated for the friction lining occur in an application at the same time, the influencing factors must be added for calculating the wear. The INTORQ Select dimensioning program can be used to calculate the maintenance intervals.

Component	Cause	Effect	Influencing factors
Friction lining	Braking during operation	Wear of friction lining	Friction work
	Emergency stops		
	Overlapping wear during start and stop of drive		
	Active braking via the drive motor with support of brake (quick stop)		
	Starting wear in case of motor mounting position with vertical shaft, even when the brake is not applied		
Armature plate and flange	Rubbing of brake lining	Armature plate and flange are run in	Friction work
Splining of brake rotor	Relative movements and shocks between brake rotor and brake shaft	Wear of splining (primarily on the rotor side)	Number of start/stop cycles
Armature plate support	Load alternation and jerks in the backlash between armature plate, sleeve bolts and guide bolt	Breaking of armature plate, sleeve bolts and guide bolt	Number of start/stop cycles, braking torque
Springs	Axial load cycle and shear stress of springs through radial backlash on reversal of armature plate	Reduced spring force or fatigue failure	Number of switching operations of brake

7 Maintenance/repair

7.2 Inspections

To ensure safe and trouble-free operation, spring-applied brakes must be checked and maintained at regular intervals. Servicing can be made easier if good accessibility of the brakes is provided in the plant. This must be considered when installing the drives in the plant.

Primarily, the necessary maintenance intervals for industrial brakes result from the load during operation. When calculating the maintenance interval, all causes for wear must be taken into account (see chapter 7.1). For brakes with low loads such as holding brakes with emergency stop, we recommend a regular inspection at a fixed time interval. To reduce the cost, the inspection can be carried out along with other regular maintenance work in the plant if necessary.

If the brakes are not maintained, failures, production outages or plant damages may be the result. Thus, a maintenance concept adapted to the operating conditions and loads of the brake must be developed for every application. The maintenance intervals and maintenance work listed in the following table must be scheduled for the spring-applied INTORQ brake.

7.2.1 Maintenance intervals

Service brakes	<ul style="list-style-type: none"> ■ according to service life calculation ■ otherwise every six months ■ after 4000 operating hours at the latest
Holding brake with emergency stop	<ul style="list-style-type: none"> ■ at least every 2 years ■ after 1 million cycles at the latest ■ plan shorter intervals for frequent emergency stops

7.2.2 Checking the component parts

With assembled brake	<ul style="list-style-type: none"> ■ Check function of ventilation and control ■ Measure the air gap (adjust if necessary) ■ Measure the rotor thickness (replace rotor if necessary) ■ Thermal damage to armature plate or flange (dark blue tarnishing) 	<p>see chapter 7.3.3</p> <p>see chapter 7.3.4</p> <p>see chapter 7.3.1</p>
After removing the brake	<ul style="list-style-type: none"> ■ Check clearance of the rotor gearing (replace worn-out rotors) ■ Wear of the torque bearing on threaded sleeves, dowel pins and armature plate ■ Checking springs for damage ■ Checking armature plate and flange/endshield <ul style="list-style-type: none"> - Evenness size 06...12 > 0,06 mm - Evenness from size 14 on > 0,1 mm - max. run-in depth = rated air gap of brake size 	<p>see chapter 7.3.5</p>

7 Maintenance/repair

7.3 Maintenance



Note!

Brakes with defective armature plates, cheese head screws, springs or flanges must be replaced completely.

Please observe the following for inspections and maintenance operations:

- Remove impurities through oil and grease using brake cleaning agents, if necessary, replace brake after finding out the cause of the contamination. Dirt deposits in the air gap between stator and armature plate impair the function of the brake and must be removed.
- After replacing the rotor, the original braking torque will not be reached until the run-in operation of the friction surfaces has been completed. After replacing the rotor, run-in armature plates and flanges have an increased initial rate of wear.

7.3.1 Checking the rotor thickness



Danger!

The motor must not be running when checking the motor thickness.

1. Remove the motor cover and seal ring (if mounted).
2. Measure the rotor thickness with a caliper gauge. On brakes with friction plates, observe edging on outer diameter of friction plate.
3. Compare measured rotor thickness with minimally permissible rotor thickness (see chapter 3.3 for applicable values).
4. Replace the complete rotor if necessary. See chapter 7.3.5 for description.

7.3.2 Check air gap

1. Measure the air gap " $s_{Lü}$ " between armature plate and rotor using a feeler gauge (see chapter 3.3).
2. Compare the measured air gap to the maximum permissible air gap " $s_{Lümax.}$ " (see table chapter 3.3).
3. If necessary, adjust air gap to " $s_{Lürated}$ ". See chapter 7.3.4.

7 Maintenance/repair

7.3.3 Release / voltage



Danger!

The running rotor must not be touched.



Danger!

Live connections must not be touched.

1. Observe the brake function during operation of the drive. The armature plate must be attracted and the rotor must move without residual torque.
2. Measure the DC voltage at the brake.
 - The DC voltage measured after the overexcitation time (see bridge/half-wave rectifier, chapter 5.1.4) must correspond to the holding voltage. A 10 % deviation is permissible.

7.3.4 Readjustment of air gap



Danger!

Disconnect voltage. The brake must be free of residual torque.



Stop!

Observe for the flange version when it is fixed with additional screws:
Behind the threaded holes for the screws in the flange there must be clearing holes in the endshield. Without clearing holes the minimum rotor thickness cannot be used. Under no circumstances may the screws be pressed against the endshield.

1. Unbolt screws (Fig. 9).
2. Screw the threaded sleeves into the stator by using a spanner. $\frac{1}{6}$ revolution reduces the air gap by approx. 0.15 mm.
3. Tighten screws (for torques see table chapter 3.3).
4. Check the air gap " $s_{L\ddot{u}}$ " near the screws using a feeler gauge (" $s_{L\ddot{u}rated}$ " see table chapter 3.3).
5. If the difference between the measured air gap and " $s_{L\ddot{u}rated}$ " is too large, repeat the readjustment.

7 Maintenance/repair

7.3.5 Rotor replacement



Danger!

Disconnect voltage. The brake must be free of residual torque.

1. Loosen connection cable.
2. Loosen the screws evenly and remove them.
3. Completely remove the stator from the end shield. Observe the supply cable.
4. Pull rotor from hub.
5. Check hub toothing.
6. In case of wear, the hub must also be replaced.
7. Check the friction surface at the end shield. In case of strong scoring at the flange, replace the flange. If scoring occurs at the end shield, re-finish end shield.
8. Measure the rotor thickness (new rotor) and head height of the threaded sleeves using a caliper gauge.
9. Calculate the distance between stator and armature plate as follows:

$$\text{Distance} = \text{Rotor thickness} + s_{\text{Lürated}} - \text{head height}$$

("s_{Lürated}" see table chapter 3.3)

10. Evenly loosen the threaded sleeves until the calculated distance between stator and armature plate is reached.
11. Install and adjust new rotor and stator (see chapter 4.3.2).
12. Reconnect the supply cable.

7 Maintenance/repair

7.4 Spare-parts list

Only parts with item numbers are available.

The item numbers are only valid for the standard design.

- Bore diameter in mm
- Standard keyway to DIN 6885/1 P9

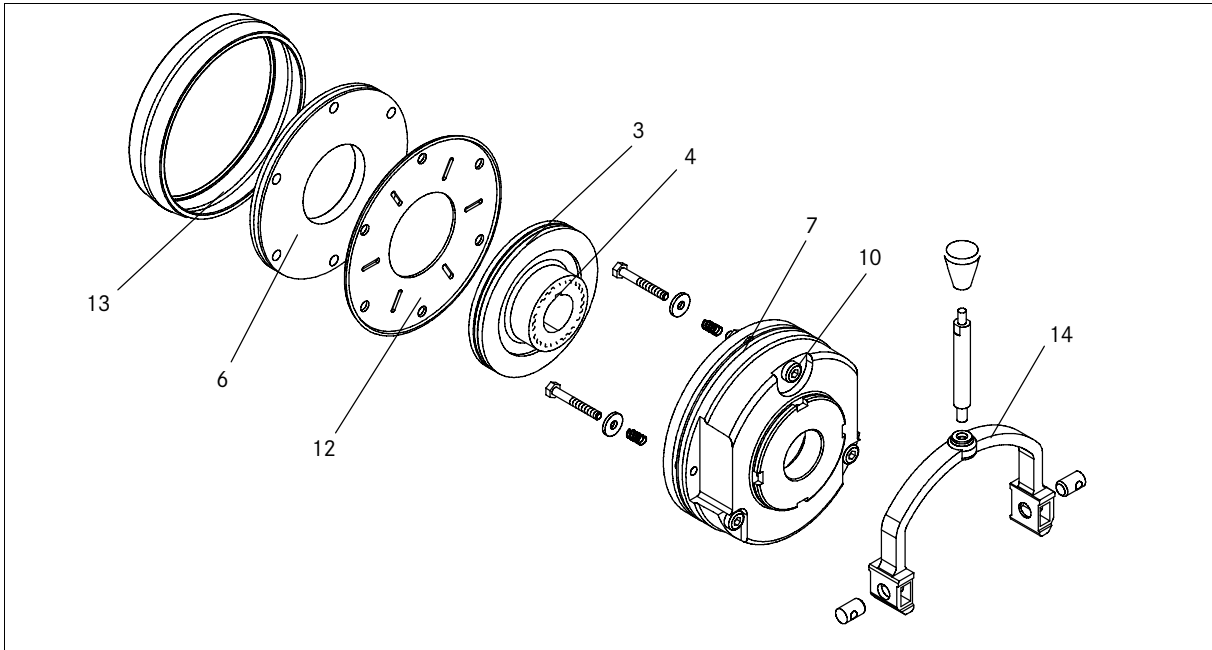

Fig. 22 Spring-applied brake INTORQ BFK458-06 to 25

Pos.	Designation	Variant
3	Complete rotor Complete rotor, low-noise version	
4	Hub	Bore
6	Flange Hartchromed flange	
7	Complete stator, module E Complete stator, module N	Voltage / brake torque
10	Set of fastening screws Allen screw DIN912 10.9	for mounting to the motor / flange Friction plate: for flange with through hole for connection flange / double brake
14	Manual release	
15	Cover seal	
	Terminal box as mounting kit	
	Speedometer flange	
	Connection flange for double brake	
	Brake cover (degree of protection corresponds to IP65)	

7 Maintenance/repair

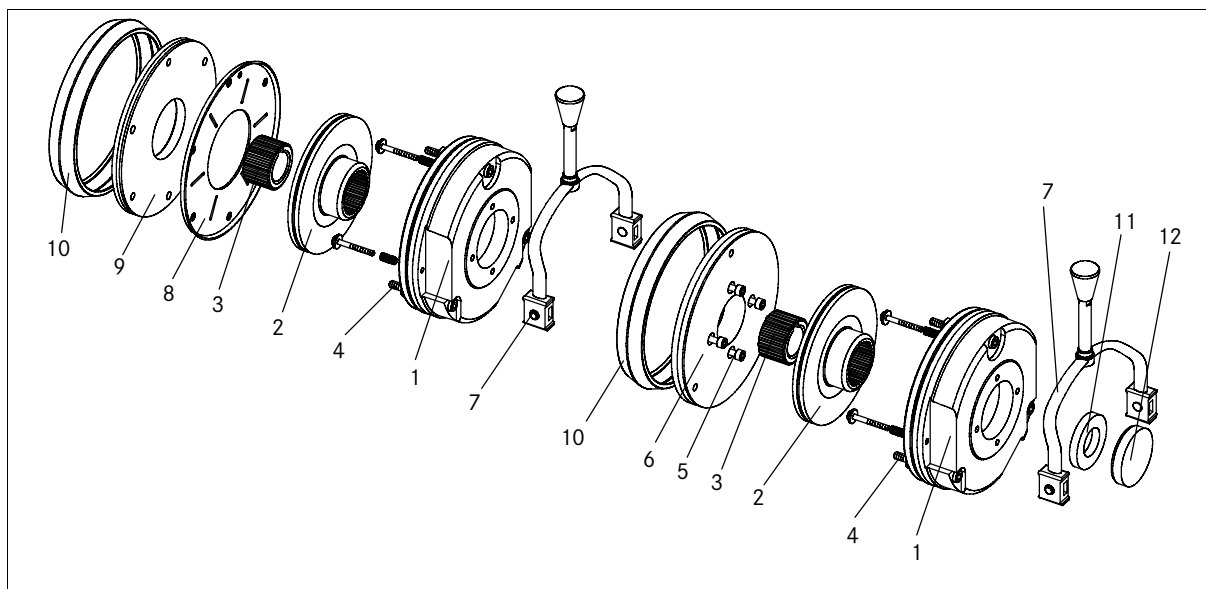

Fig. 23 Double spring-operated brake INTORQ BFK458-06 to 25

Pos.	Designation	Variant
1	Complete stator, module N	Voltage / brake torque - as option with noise-reduced armature plate
2	Complete rotor	Aluminium rotor
		Aluminium rotor with sleeve - Low-noise version
3	Hub with standard bore	Hole diameter [mm] slot according to DIN 6885/1
4	Set of fastening screws; Allen screw DIN912 10.9	■ for mounting to the flange ■ for mounting to the motor / friction plate ■ for flange with through hole
5	Set of fastening screws; Allen screw DIN912 10.9	for connection flange / double brake
6	Connection flange for double brake	
7	Manual release with standard lever	Mounting kit
8	Friction plate	
9	Flange	
	Hartchromed flange	
10	Cover seal	
11	Shaft seal	Shaft diameter on request
12	Cap	Basic module N

7 Maintenance/repair

7.5 Spare parts order

INTORQ BFK458-□□□ / complete stator

- Size** 06 08 10 12 14
 16 18 20 25
- Design** E (with adjuster nut) N (without adjuster nut)
- Voltage** 24 V 96 V 103 V 170 V 180 V
 190 V 205 V
- Braking torque** _____ Nm (see torque ranges)
- Cable length** Standard
 _____ mm (from 100 mm to 1000 mm in 100 mm steps,
 from 1000 mm - 2500 mm in 250 mm steps)
- Manual release** mounted
- Armature plate** Standard with washer/brass foil
 noise-reduced (O-ring version) hartchromed
- Microswitch** Monitoring of the switching function (from size 12 on)
 Wear monitoring (from size 12 on)
- Terminal box** mounted (from size 12 on)

Accessories

- Rotor** Aluminium Low-noise version (rotor with sleeve)

 Plastic (only size 06/08)
- Hub** _____ mm (for bore diameter, see dimensions)
- Set of fixing screws** for mounting to the flange
 for mounting to the motor / friction plate
 for flange with through holes (up to and including size 16)
 for connection flange / double brake
- Manual release** as mounting kit
- Terminal box** as mounting kit
- Flange** Friction plate (up to and including size 16)
 Flange
 Speedometer flange
 Connection flange / double brake
- Sealing** Cover seal
 Shaft seal (shaft diameter on request)
 Cap
 Brake cover

7

Maintenance/repair

Electrical accessories

Rectifier type	AC voltage [V AC]	Coil voltage release/holding [V DC]	Assigned brake
BEG-561-255-030 BEG-561-255-130	230 ±10%	205 / 103	BFK458-06...25
BEG-561-440-030-1 BEG-561-440-130	400 ±10%	360 / 180	

8 Troubleshooting and fault elimination

If any malfunctions should occur during operation of the drive system, please check the possible causes using the following table. If the fault cannot be eliminated by one of the listed measures, please contact the aftersales service.

Fault	Cause	Remedy
Brake cannot be released, air gap is not zero	Coil is interrupted	<ul style="list-style-type: none"> ■ Measure coil resistance using multimeter: <ul style="list-style-type: none"> - If the resistance is too high replace the stator.
	Coil has interturn fault or short circuit to ground	<ul style="list-style-type: none"> ■ Measure coil resistance using multimeter: <ul style="list-style-type: none"> - Compare measured resistance to rated resistance. For values, see chapter 3.3. If the resistance is too low, replace the entire stator. ■ Test the coil for short circuit to ground using a multimeter: <ul style="list-style-type: none"> - If a short circuit to ground occurs, replace the stator. ■ Check the brake voltage (see defective rectifier, voltage too low).
	Defective or wrong wiring	<ul style="list-style-type: none"> ■ Check and correct wiring. ■ Check the cable using a multimeter: <ul style="list-style-type: none"> - Replace defective cable
	Defective or wrong rectifier	<ul style="list-style-type: none"> ■ Measure the DC voltage at the rectifier using a multimeter. When the DC voltage is zero: <ul style="list-style-type: none"> ■ Measure the AC voltage at the rectifier. When the AC voltage is zero: <ul style="list-style-type: none"> - Apply voltage - Check fuse - Check wiring When the AC voltage is ok: <ul style="list-style-type: none"> - Check rectifier - Replace defective rectifier When the DC voltage is too low: <ul style="list-style-type: none"> - Check rectifier - If diode is defective, use suitable new rectifier ■ Check the coil for fault between turns and short circuit to ground. ■ If the rectifier defect occurs again, replace the entire stator, even if you cannot find any fault between turns or short circuit to ground. The fault may occur later during heating-up.
	Incorrect wiring of microswitch	Check the wiring of the microswitch and correct it.
	Incorrect setting of microswitch	Replace the stator and complain about the micro switch quality at the manufacturer
	Air gap too big	Readjust the air gap (chapter 7.3.4)
Rotor cannot rotate freely	Wrong setting of manual release	Check dimension $s+s_{L\ddot{u}}$ with energised brake. The dimension must be identical at both sides. Correct if necessary.
	Air gap $s_{L\ddot{u}}$ too small	Check air gap $s_{L\ddot{u}}$ and readjust it, if necessary (chapter 7.3.4).

8 Troubleshooting and fault elimination

Fault	Cause	Remedy
Rotor not thick enough	Rotor has not been replaced in time	Replace rotor (chapter 7.3.5)
Voltage is not zero when checking the operation (6.2.2 or 6.2.3)	Incorrect wiring of microswitch	Check the wiring of the microswitch and correct it.
	Defective microswitch or incorrect setting	Replace the stator and send the defective stator to the manufacturer.
Voltage too high	Brake voltage does not match the rectifier	Adapt rectifier and brake voltage to each other.
Voltage too low	Brake voltage does not match the rectifier	Adapt rectifier and brake voltage to each other.
	Defective rectifier diode	Replace rectifier by a suitable new one.
AC voltage is not mains voltage	Fuse missing or defective	Select a connection with proper fusing.
	Incorrect wiring of microswitch	Check the wiring of the microswitch and correct it.
	Defective microswitch or incorrect setting	Replace the entire stator and return it to the manufacturer.



INTORQ – Sales and Service around the world

INTORQ customers can reach us at any time and from anywhere in the world. Our Key Account Sales Team looks after key account customers and project business.

In addition, we co-operate with Lenze's global sales organisation. You can contact us via Lenze Service by calling the 24-hour helpline (008000 24 46 177).

INTORQ GmbH & Co KG

Postfach 1103
D-31849 Aerzen

Wülmser Weg 5
D-31855 Aerzen

Tel.: +49 (0) 51 54 95 39-01

Fax: +49 (0) 51 54 95 39-10

E-Mail info@intorq.de

www.intorq.de

INTORQ

setting the standard

www.intorq.de