

Thyristor Controllers  
SGP 160-2,5/4/8P/16P  
Assembly- and Commissioning Instructions



as per 05/16 12300.10004

<b>Table of Contents</b>	<b>Page</b>
1. Safety notes	3
2. Conformity	3
3. General description	4
4. Usage to the intended purpose	4
5. EC Declaration of Conformity	5
6. Block diagram	6
7. Functional description	6
8. Technical data	7
8.1 Ambient conditions	7
9. Installation	8
9.1 Connection	8
9.2 Power unit	8
9.3 Control unit	8
10. Parameter adjustments	9
10.1 Ramp-up and ramp-down times	9
10.2 Maximum speed	9
10.3 Minimum speed	9
10.4 I x R compensation with armature voltage control	9
10.5 Current limitation I <sub>max</sub>	9
10.6 Adapting the resistor R21 for tachometer control	9
10.7 RC circuit of the speed controller	10
11. LED indicators	10
12. Remediying faults	10
13. Installation guidelines	11
13.1 Connection diagram SGP 160-2,5 (P) /4 (P)	11
13.2 Connection diagram SGP 160-8P/16P	12
13.3 Dimensional drawing	13
13.4 Radio interference suppression and shielding	14
13.5 Arrangement	14
13.6 Shielding	14
13.7 Cabling	15

These commissioning instructions were prepared with great care. Nevertheless, PETER electronic GmbH & Co. KG does not assume liability for damage resulting from mistakes possibly contained in this manual. Technical changes that serve to improve the product are subject to change without notice.

### Notes and symbols used in these instructions

**Note:** Notes explain the advantages of certain adjustments or settings and help you to make use of the device in the best possible way.



**Warning notices: Read them carefully and follow them strictly!**

Warning notices are indicated in order to protect you against danger or to help you to prevent the device from being damaged.



**Caution: Danger to life through electric shock!**

When you see this sign, always make sure that the device is de-energized and secured against unintentional energizing.

---

## 1. Safety notes



The described devices are electrical equipment for use in industrial electrical power installations. An impermissible removal of the covers during operation can cause serious damage to your health, since these devices contain live parts with high voltages.

Adjustment work may only be performed by trained staff observing the safety regulations. Assembly and mounting work may only be carried out with the equipment deenergized.

Make sure that all drive components are properly earthed.

Please read these commissioning instructions carefully before putting the device into operation.

Besides, the user must ensure that the devices and associated components are fitted and connected in accordance with the applicable local, legal and technical regulations. The VDE-regulations VDE 0100, VDE 0110 (EN 60664), VDE 0160 (EN 50178) , VDE 0113 (EN 60204, EN 61310), VDE 0660 (EN 50274) plus the appropriate regulations of the TÜV (Technical Control Association) and the trade associations apply in Germany.

The user must ensure that the drive turns into a safe operating state following a device failure, in the event of maloperation, or if the control unit has failed etc..

**Caution:** Even if the motor is at rest, it is **not** physically separated from the mains.

## 2. Conformity

In industrial linguistic usage the drive controllers of the type SGP 160-2.5/4/8P/16P are called "devices", however, in the sense of the "device-safety-law", the "EMC-law" or the "EC-guideline for machinery" they are not devices or machines ready for use or connection but they are components. It is only possible to define their final function, when these components are integrated into the design and construction of the user.

**To be able to use the devices to their intended purpose, it requires power supply networks according to DIN EN 50160 (IEC38).**

The user takes the responsibility that the user's design and construction comply with the applicable legal provision.

The commissioning is strictly forbidden as long as the conformity of the final product with the guidelines 2006/42/EC (Machinery directive) and 2006/95/EC (Low voltage directive) is not proved.

---

### **3. General description**

The electronic speed controllers SGP 160-2.5/4/8P/16P are used for the speed control of d.c. shunt-wound motors with external and permanent excitation. A remarkable feature of these controllers is the high speed stability, irrespective of fluctuations in temperature, voltage and load. By means of the controllers SGP 160-2.5/4/8P/16P it is possible to make a variety of adjustments, such as minimum and maximum speed, ramp-up and ramp-down time, current limitation, as well as  $I \times R$  compensation. Since the controller is equipped with mains-potentialfree control inputs, an external control is easily possible. Since the controller can be equipped with mains-potential-free control inputs, an external control is easily possible.

### **4. Usage to the intended purpose**

The devices of the SGP 160-2.5/4/8P/16P-series are electrical equipment that is used in industrial electrical power installations. They are designed for the application in machines, in order to control speed-variable drives with d.c. motors.

#### **Typical Applications**

- conveying systems
  - printing machines
  - pumps
  - rotary table drives
  - welding wire feed mechanisms
  - packaging machinery
-

**5. EC Declaration of Conformity****EC Declaration of Conformity** 

The manufacturer / company placing the product on the market  
(authorized representatives of the manufacturer / companies placing the product on the market  
that are established within the Community)

Name / Address: PETER electronic GmbH & Co. KG  
Bruckäcker 9  
92348 Berg

hereby declares that the following product (device, component, unit) in the version as supplied

**Product designation:** DC Thyristor Controller  
Series / type designation: SGP 160-2,5/4/8P/16P  
Article number: 223...  
Year of manufacture: 1999

complies with the provisions of the following EU-directives:

- 2014/30/EU** Electromagnetic compatibility
- 2014/35/EU** Electrical equipment designed for use within certain voltage limits
- 2011/65/EU** The restriction of the use of certain hazardous substances in electrical and electronic equipment

The following harmonized standards have been applied:

- EN 60947-1:2007+A1:2012** Low-voltage switchgear and controlgear General rules
- EN 60947-4-2:2012** Low-voltage switchgear and controlgear  
Contactors and motor-starters - AC semiconductor motor  
controllers and starters

This EC Declaration of Conformity is no longer valid, if the product is modified or changed  
without our agreement.

This declaration is issued under the sole responsibility of the signatory.

Berg, 15.04.2016 Dr. Thomas Stiller, Managing director  
(place, date) (signatory and function of the signatory)

  
(signature)

## 6. Block diagram

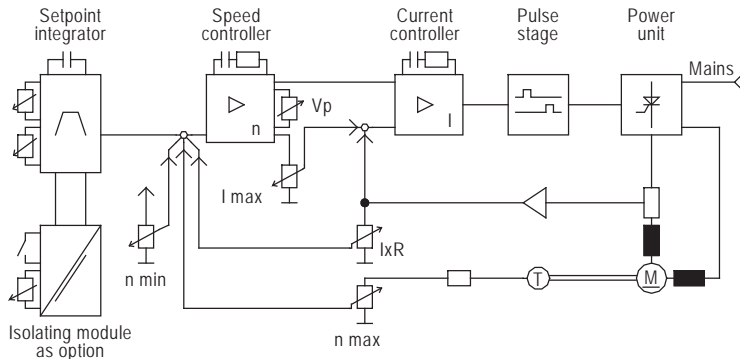

## 7. Functional description

### Speed setpoint

The setpoint voltage is 0 ... 10VDC. The setpoint value can be generated either by means of the potentiometer or externally. By connecting a 500 Ohm resistor in parallel to the setpoint input terminals it is possible to feed in a setpoint current of 0...20mA. With the setpoint integrator it is possible to realize an acceleration and deceleration time that is linear in time.

### Speed controller

The speed controller is designed alternatively for tachometer control or armature voltage control with adjustable  $I \times R$  compensation.

### Current controller

The current controller generates the control voltage for the pulse stage. If the current actual value exceeds the adjusted current setpoint, the motor voltage will be reduced. Thus the motor and the drive are not overloaded.

### Pulse stage

The pulse stage generates the control pulses for the thyristors. Their length from the trigger point to the next zero crossing of the voltage wave enables a safe operation of the device even under highly inductive load.

### Power unit

The power unit consists of a single-phase, half-controllable bridge circuit and an exciting-voltage source. The circuit additionally includes measures to protect the power semiconductors against overvoltage.

SGP 160-2,5/4/8P/16P

7

## 8. Technical data

	SGP 160-2,5	SGP 160-4	SGP 160-8P	SGP 160-16P
Operating voltage acc. to DIN EN 50160 (IEC38)	230V ±15% 50/60Hz			
max. Motor shaft power	0,25kW	0,37kW	0,9kW	1,8kW
Armature voltage	0 ... 180VDC			
eff. Armature current	2,5A	4A	8A	16A
Excitation voltage / current	200V / 0,5A		200V / 1A	
Control characteristics with I x R compensation with tachometer control	1:30 / ±3% 1:100 / ±1%			
Setpoint input	0 - 10VDC / mains potential-free with option „P“ 5 - 10k Ohm potentiometer			
Actual value input	12 - 300VDC depending on adaptation factory-adapted to 160V armature voltage			
Device fuse (internal)	4A	6,3A	160mA / 2x 20A	
Connection	16-pole terminal strip		control unit: 6-pole terminal strip power unit: 6-pole terminal strip	
Connection option „ST“	31-pole Plug-connector DIN 41617		-	

### 8.1 Ambient conditions

Operating temperature	0 ... 45°C not subj. to moisture condensation
Storage temperature	-25 ... 75°C
Cooling	Convection
Temperature-dependent power reduction	2%/°C above 45°C max. 55°C
Protection class	IP 00
Environment	Overvoltage category III, pollution degree 2



## 9. Installation

To realize the power rating, the device is to be fastened on a vertical mounting surface, with the terminal strip facing either to the left or to the right. Make sure that no additional heat sources, such as heaters, radiators or power resistors are placed underneath the device. For dimensions and fixing holes refer to the dimensional drawing.

### 9.1 Connection

Only connect according to the attached terminal diagram.

### 9.2 Power unit

(Terminal strip version acc. to DIN 41617 indicated in brackets only for SGP 160-2,5/4)

SGP 160-2,5/4	SGP 160-8/16P	
Terminal 16 (1, 2)	220V 50/60Hz	Mains Phase L
Terminal 8 (17, 18)	220V 50/60Hz	Mains neutral conductor N
Terminal 10 (13, 14)	+A	Armature A+
Terminal 12 (9, 10)	+C	Field winding F+
Terminal 13 (7, 8)	-D	Field winding F-
Terminal 14 (5, 6)	-B	Armature -B

### 9.3 Control unit

Terminal 1 (31)	Controller inhibit 24V	When the contact is open,
Terminal 2 (29, 30)	Controller inhibit Input	the controller is inhibited
Terminal 3 (27, 28)	Setpoint potentiometer 10VDC	
Terminal 4 (25, 26)	Setpoint input 0 ... 10VDC	
Terminal 5 (23,24)	Setpoint potentiometer Base point	
Terminal 6 (21,22)	Actual value input	

#### 9.3.1 Option „P“

In the case of option „P“ the control terminals for the controller inhibit and the setpoint are potential-free and may be connected to earthed systems.



#### Attention!

A protective/safety separation, however, is not achieved.

## 10. Parameter adjustments

### 10.1 Ramp-up and ramp-down times

With the trimmer  $t_{int}$  (P2) the ramp-up and the ramp-down can be adjusted between 0 ... approx. 5sec. When the controller inhibit is actuated, the ramp-up integrator is reset.

### 10.2 Maximum speed

With the trimmer  $n_{max}$  (P3) max. armature voltage can be limited between 90 ... 180V.

### 10.3 Minimum speed

With the trimmer  $n_{min}$  (P4) the minimum speed can be limited to 0 ... 50% of the adjusted maximum speed.

### 10.4 I x R compensation with armature voltage control

The compensation voltage is adjusted with the trimmer I x R (P1). The compensation increases if the trimmer is turned clockwise. The adjustment is to be made when the motor has its normal operating temperature. The drive is to be adjusted to approx. 50% of the nominal speed, unloaded as far as possible, and the speed is to be measured.

Then load the drive and compensate the resulting speed drop with the trimmer P1. Afterwards check the effects of the compensation at minimum and maximum speed and re-adjust if necessary. Make sure that an over-compensation, i.e., a speed rise under load, is avoided at any rate, as otherwise the drive becomes unstable. In the case of tachometer control the potentiometer P1 is set to left stop.

### 10.5 Current limitation $I_{max}$

As a rule, the current limitation is to be adjusted with the potentiometer  $I_{max}$  (P5) so that the maximum current required for the start-up and acceleration is provided. In the case of gearmotors make sure that the limit torque of the gearing is not exceeded by adjusting the limit current too high.

### 10.6 Adapting the resistor R21 for tachometer control

When the controller is operated with a d.c. tachometer, it may be necessary to adapt the resistor R21 accordingly (depending on the amount of the tachometer voltage at nominal speed). Basically, only resistors with a loading capacity of 1 watt are to be used. The trimmer I x R is set to left stop. The resistance value can be determined with the following formula.

$$\frac{U_{Tacho} \times n_{Motor}}{1500} - 10 = R21(k\Omega)$$

$U_{Tacho}$  = voltage value of the d.c. tachometer in volts per 1000 revolutions

$n_{Motor}$  = nominal speed of the motor at  $U_{Armature\ max}$ .

The calculated resistance is to be inserted in k Ohm.

---

### 10.7 RC circuit of the speed controller

The circuit of the speed controller is so designed that the controller can be used for a variety of drive cases without changing the circuit. However, in some extreme cases, e.g., heavy gyrating masses of the machines, it may become necessary to change the factory-installed circuit.

Designation	factory-installed	Function
R27	560k Ohm	Adjustment of the P-gain By increasing the resistance the P-gain is increased too.
C17	2,2 $\mu$ F	Adjustment of the I-gain By increasing the capacitance of the capacitor the integral-action time is prolonged

### 11. LED indicators

2 LEDs visually indicating the operational status are located on the control board.

green LED: The controller is ready for operation; supply voltage is available.

red LED: The controller inhibit is activated and the motor has been stopped.

### 12. Remediying faults

The devices are designed for a problem-free and safe operation. Nevertheless, should trouble arise, the following list is meant to help you to remedy the fault.

Fault	Reason
Motor will not run	<ul style="list-style-type: none"> <li>- no mains voltage</li> <li>- defective fuse</li> <li>- no setpoint</li> <li>- terminals 1 and 2 for controller inhibit not closed</li> <li>- potentiometer <math>I_{\max}</math> on left stop</li> </ul>
In the case of a small setpoint the motor runs up and cannot be controlled	<ul style="list-style-type: none"> <li>- no actual value of speed</li> <li>- connection between terminals 6 and 14 is missing (SGP 160-8/16P Klemmen B- and 6)</li> <li>- tachometer not connected or reversed polarity</li> <li>- R21 too high resistance</li> <li>- externally excited motors: exciter field is not connected</li> </ul>
Motor does not run up to speed	<ul style="list-style-type: none"> <li>- R21 incorrectly adapted (too low resistance)</li> <li>- motor too large or <math>I_{\max}</math> adjusted to a too small value</li> <li>- setpoint too small or setpoint potentiometer wrongly connected</li> </ul>
Motor swings	<ul style="list-style-type: none"> <li>- I x R compensation adjusted too high</li> <li>- heavy gyrating masses of the drive</li> </ul> <p>The controller RC circuit has to be changed</p>

### 13. Installation guidelines

#### 13.1 Connection diagram SGP 160-2,5 (P) /4 (P)

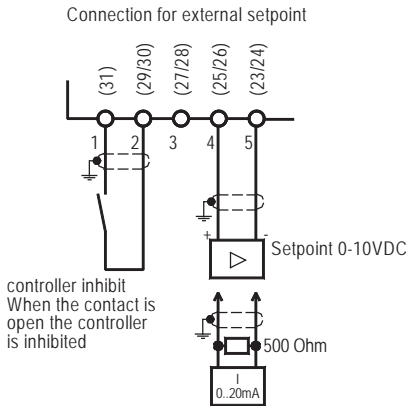
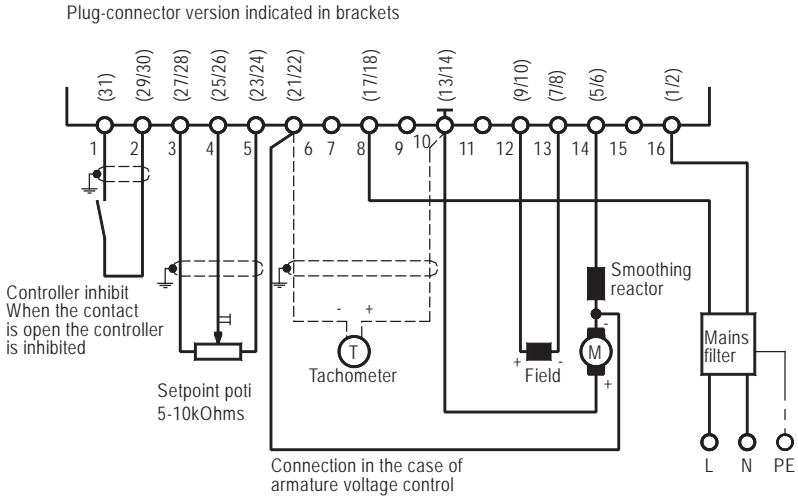

13.2 Connection diagram SGP 160-8P/16P

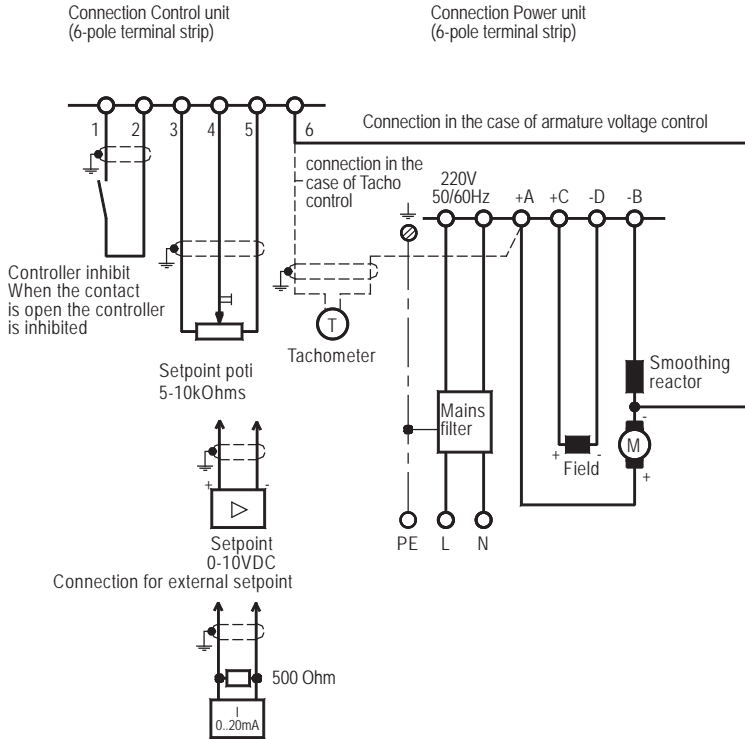

**13.3 Dimensional drawing**

SGP 160-2,5/4  
 Depth: SGP 160-2,5 = 35mm  
 SGP 160-4 = 45mm

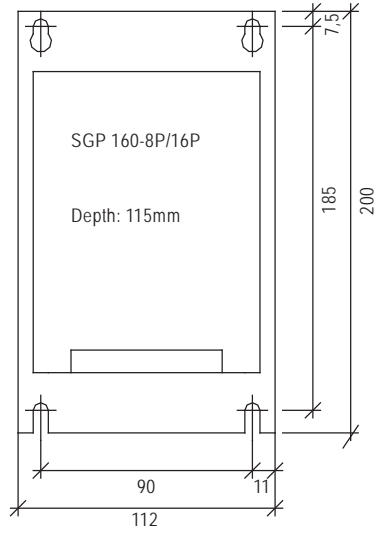
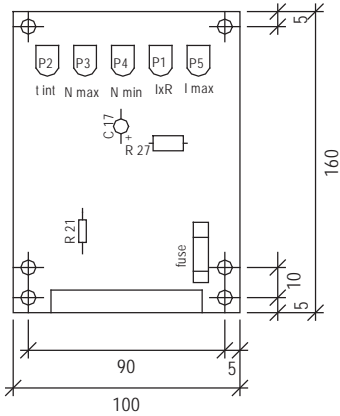

### 13.4 Radio interference suppression and shielding

Even when installing thyristor controllers, interference from the realm of radio interference suppression and immunity must be reduced to a tolerable level (EC-EMC-guidelines). An interference suppression that has to be subsequently implemented in an already installed system often causes high costs.

The use of interference suppression filters in the mains supply line or on the output alone does not resolve these interference problems. These problems can only be solved by an appropriate **arrangement** of the filter elements, and a proper implementation of the **cabling** and **shielding**. However, whether the radio interference limit values are complied with can only be checked by measurements.

### 13.5 Arrangement

The controller and the filter have to be mounted as close as possible next to each other and must be earthed with a large-surface contact. This is best done by means of a mounting plate (figure 1). The varnish on the contact areas of this mounting plate must be removed in advance. The varnish on the contact areas of the controller or the filter has to be removed too.

Some switchgear cabinet suppliers offer mounting plates with conductive coating.

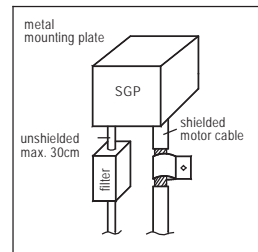

Figure 1

### 13.6 Shielding

To prevent the controller from radiating interfering energy to the environment, the controller should be installed in a metal-enclosed housing (switchgear cubicle or switchbox); the following cables must be shielded:

- Cable between mains filter and controller, if it is longer than 30cm.
- Control cables, if they are longer than 2m.

Cables for digital signal transmission must be connected on both ends to the earth potential.

Cables for highly impedant analog control signals (setpoint value) must only be earthed on one side in order to avoid a 50Hz-hum.

The shield bondings must always be implemented with large-surface contact. (Figure 2a,2b). Therefore bondings with sheath wire, via connector pins or wire connectors are not allowed (Figure 2c).

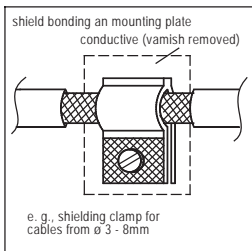
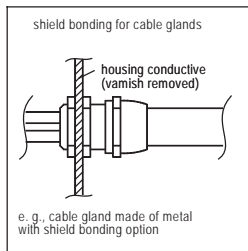
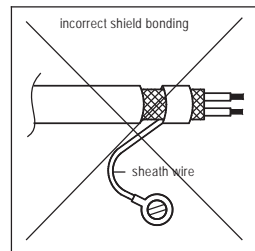

Figure 2a



2b



2c

### 13.7 Cabling

To avoid mutual interference/cross couplings when laying the cables, it must be ensured that a minimum distance of 20 cm is maintained between control cables and power cables. If control cables have to cross power cables they have to be laid at an angle of 90° (Figure 3).

When connecting shielded cables make sure that the unshielded cable ends are as short as possible. The large-surface shield bonding must not necessarily be located on the end of the shielding but may also be established in a suitable place - at a distance of some centimetres. The shield must always be connected on both ends to ground (Figure 4).

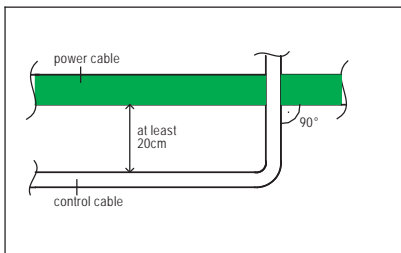

Figure 3

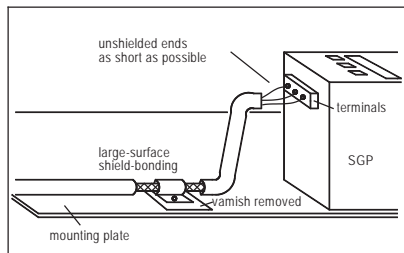

Figure 4



#### ATTENTION!

When using mains filters the leakage currents are increased.

For the respective leakage currents please refer to the corresponding data sheets.

Leakage currents up to 3.5mA and permanent connection require no special additional earthing measures.

According to VDE 0160 (EN 50178) the following applies to the most common applications:

If in the case of permanently connected devices an operational leakage current of 3.5mA is exceeded, one of the following conditions must be complied with.

1. Protective conductor cross section of at least 10mm<sup>2</sup>
2. Monitoring of the protective conductor by means of a device/system which in case of a fault causes an automatic switch-off.
3. Installation of a second conductor, electrically in parallel to the protective conductor via separate terminals. This conductor by itself must meet the requirements according to VDE 0100, part 540.

#### Recommended filters:

mains filter	NF 250/6	Article-No.27000.25006
	NF 250/10	Article-No.27000.25010
	NF 250/20	Article-No.27000.25020







[www.peter-electronic.com](http://www.peter-electronic.com)

