

**Operating and Maintenance Manual – KG Series**

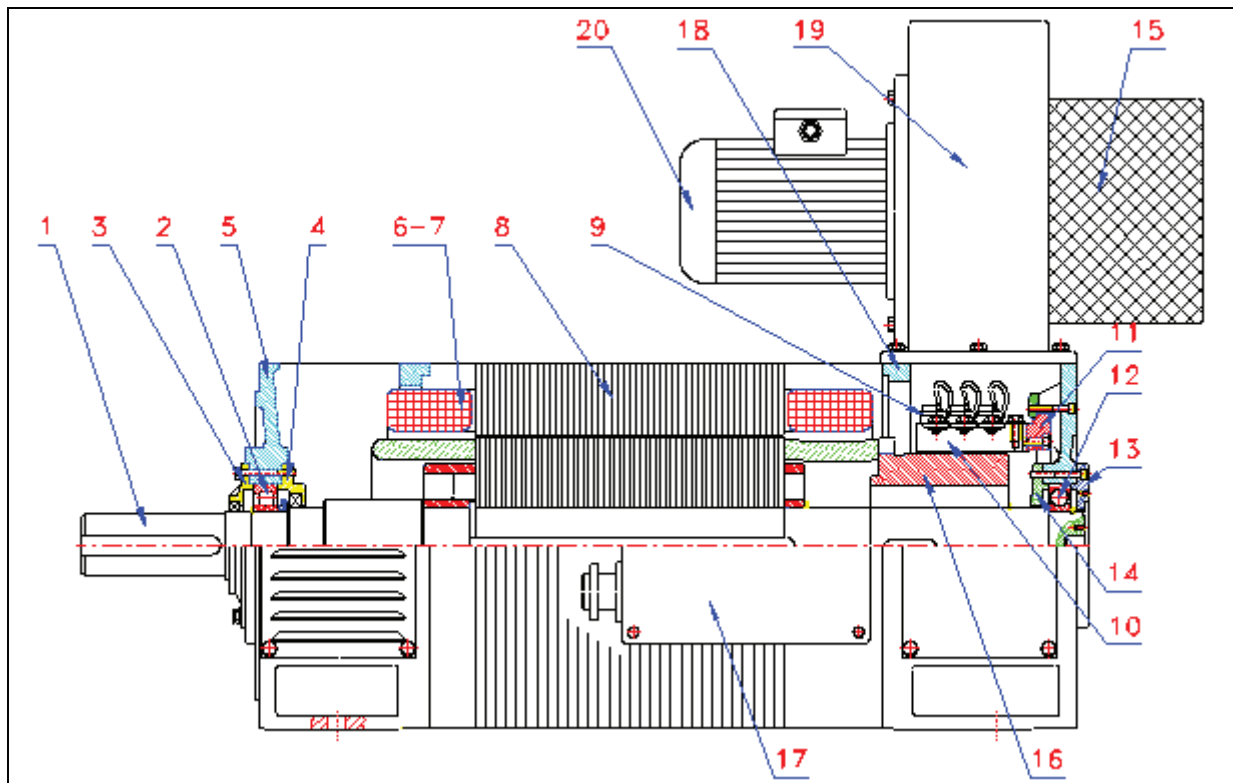

**1. WARNING !**

High voltage and rotating parts can cause serious or fatal injury. Installation, operation and maintenance of DC motor should be performed by qualified personnel.

Figure 1

- 1 – Shaft
- 2 – Drive end bearing
- 3 – Drive end outer bearing cap \*
- 4 – Drive end inner bearing cap \*
- 5 – Drive end bearing bracket
- 6 – Main pole coils
- 7 – Commutating pole coils
- 8 – Frame
- 9 – Brush
- 10 – Brush holder
- 11 – Brush holder ring
- 12 – Opposite drive end bearing
- 13 – Opposite drive end outer bearing cap \*
- 14 – Opposite drive end inner bearing cap \*
- 15 – Fan filter support
- 16 – Commutator
- 17 – Conduit box
- 18 – Opposite drive end bearing bracket
- 19 – Blower frame
- 20 – Blower motor \*

\* Availability is subject to change depending on the model of the motor

**2. INSTALLATION**

The DC Motor must be installed in a place where the air outlets are free, and easy access to the brushes from the non driving end is always possible. Keep the hot out flowing air from being recirculated.

**3. MOUNTING**

The DC Motor must be placed on firm foundations. Supporting surface must be level. Excessive vibration of the motor may be caused by weak foundation. After having aligned motor and machine, the base plate must be secured to the foundation with concrete. If this is not possible, the supporting structure must be firm enough to ensure freedom from vibration.

**4. COUPLING**

This operation is extremely important for the life of the motor and must be carried out with great care.

The B3 type motors must be secured using four screws whose diameter fits in with the base plate holes and adding two tapered dowels between two diagonally opposed feet. The motors, type B5 and V1, must be secured to the counter flange in a similar way.

**4.1. Direct Coupling**

It is advisable to make use of flexible joints which can prevent the transmission of any axial stresses to the bearings.

A good alignment requires the use of comparators correctly fitted on the two shaft ends (see figure 2).

The transmission gear must have sufficient gap, allowing for axial expansions due to heat.

Figure 2

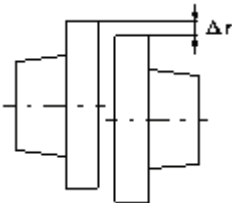
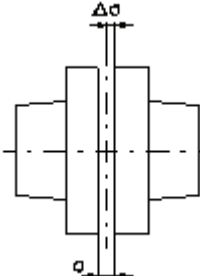
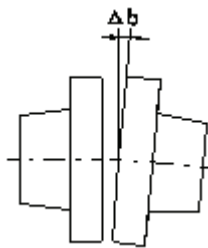
	Radial Tolerance	
	Axial Tolerance	
	Angular Axial Tolerance	
Radial Tolerance $\Delta r = \pm 0.1 \text{ mm}$	Axial Tolerance $\Delta b = \pm 0.1 \text{ mm}$	Angular Axial Tolerance $\Delta a = 1 - 3 \text{ mm}$

## 4.2. Belt Coupling

The parallelism between the shafts and the alignment of the pulleys must be as accurate as possible in order to prevent axial stresses on the bearings. The pulleys must be fitted as near as possible to the base plate of the motor. The axial length of the pulley must not exceed twice the length of the shaft extension.

## 5. STARTING

### WARNING !

Before making any electrical connection be sure that the drive is switched off.

Make the electrical connection of DC motor according to the diagrams below.

### Separate excitation DC Motor interconnection diagrams

Clockwise rotation facing drive end

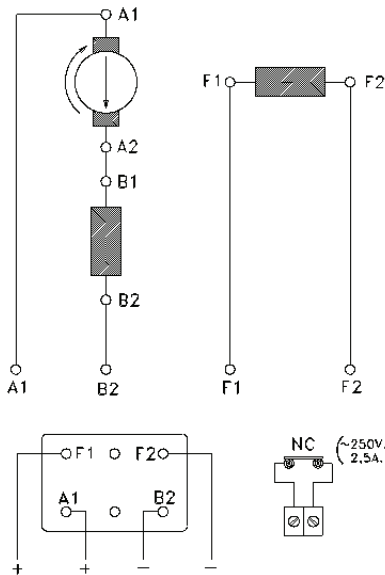

Counterclockwise rotation facing drive end by field inversion

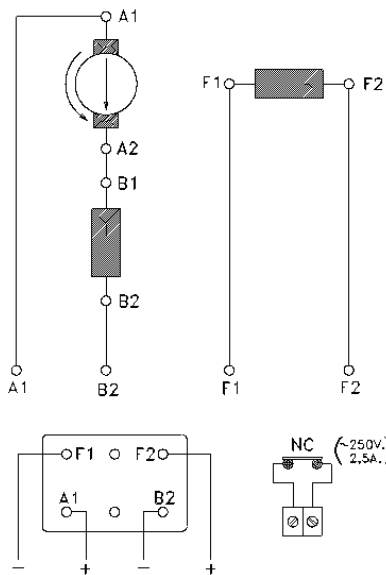

Counterclockwise rotation facing drive end by armature inversion

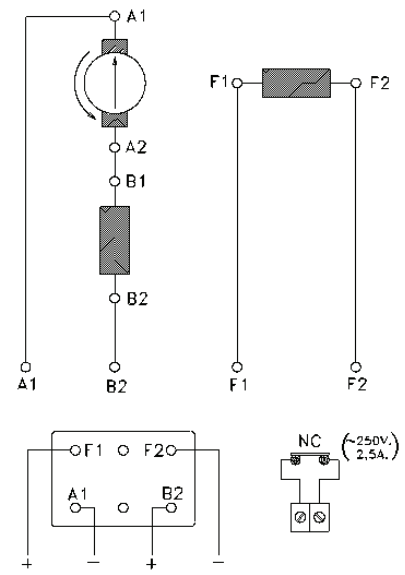

For external fan connection diagram consult FEMSAN if necessary.

## 5.1. Inspection Before Starting

Before putting the motor into operation, or after a long period of inactivity, it is advisable to check the following :

- 1 – Test the insulation to the earth of the armature and field with the Megger; it must not be lower than 2 MΩ.
- 2 – Make sure that the ventilating fan is connected for the line voltage and check the sense of rotation of the fan. It must correspond to the sense of the arrow stamped on the fan. The brush inspection doors must always be closed; otherwise the fan motor is overloaded, which consequently may cause damage.
- 3 – Make sure that the electrical connections have been made according to the enclosed diagram.
- 4 – Inspect the inside of the motor, there operation must not be any foreign articles. Turn the rotor by hand, it must turn smoothly and without hindrances.
- 5 – Check the tightness of the securing bolts on the base plate.
- 6 – Check the fastening of the brush cables, they must not interfere with the brush springs. The commutator surface and the grooves between segments must be clean.
- 7 – If the purchased motor is fitted with the bearing requiring lubrication, check their correct lubrication and replenish with grease if necessary.

<b>5.2. Inspection After Starting</b>
<p>Check the following as soon as the motor has been started:</p> <p>1 – Leave the motor in operation for some hours under a moderate load and look for possible localized overheating.</p> <p>2 – Check the temperature of the bearings. It must not exceed 90 °C.</p> <p>3 – Check that operation is smooth and free from vibration.</p>

<b>MAINTENANCE PROGRAM</b>		
PART	OPERATION	INTERVAL
Commutator	Check that the commutator is clean and that there is no burns on the segments.	Every Month
	Check the eccentricity.	Every 3 Months
	Cleaning the grooves between the segments.	Every Year
Brushes	Check for brush wear and play in the brush holder. Usually the brushes last from 6 months to 1 year.	Every Month
	Check brush pressure and connections.	Every 3 Months
Bearings	Check their temperature and the absence of vibrations and noise.	Every 3 Months
	For lubrication bearings only : check the grease level and replenish if necessary.	Every 3 Months
Insulation	Particularly if location is damp, check the insulation value with the Megger : it must be never be less than 1.5 MΩ	Every Month
Filters	Check for possible filter cloggings; wash the filtering material if necessary. After repeated washes it must be replaced.	Every Month
Screws	Check tightening.	Every Month
	Check the electrical connections : poor contact may cause localized overheating.	Every 6 Months
Windings	Overall cleaning. Check the insulation to earth : its value must be greater than 1.5 MΩ	Every Year

<b>6. MAINTENANCE</b>
<p>A detailed programme of maintenance is the first condition necessary to ensure good working and long working life.</p> <p><i>WARNING !</i></p> <p><i>Disconnect power before touchinng any internal part.</i></p>

<b>6.1. BRUSHES</b>
<p>A homogeneous and glossy brush surface is an index of a good commutation. Two opaque strips on the sides are also acceptable. A fully opaque or a spot opaque surface indicates a critical commutation and therefore it must be checked.</p>

**Table 1.**

<b>Brush Dimensions and Quantities</b>		
<u>Type</u>	<u>Dimension</u>	<u>Quantity</u>
<u>KG Series</u>		
K.08.07.ST	10 X 20 X 40	2
K.08.10.ST	10 X 20 X 40	2
K.09.15.ST	10 X 20 X 40	2
K.09.20.ST	10 X 20 X 40	2
K.09.25.ST	10 X 20 X 40	2
K.10.10.ST	12.5 X 20 X 40	2 - 4
K.10.14.ST	12.5 X 20 X 40	2 - 4
K.10.23.ST	12.5 X 20 X 40	2 - 4
K.10.28.ST	12.5 X 20 X 40	2 - 4
K.13.12.ST.	10 X 25 X 40	4 - 8
K.13.16.ST.	10 X 25 X 40	4 - 8
K.13.20.ST.	10 X 25 X 40	4 - 8
K.13.25.ST.	10 X 25 X 40	4 - 8
K.13.30.ST.	10 X 25 X 40	4 - 8
K.16.13.ST	12.5 X 32 X 40	4 - 8
K.16.18.ST	12.5 X 32 X 40	4 - 8
K.16.26.ST	12.5 X 32 X 40	4 - 8
K.16.30.ST	12.5 X 32 X 40	4 - 8
K.16.40.ST	12.5 X 32 X 40	4 - 8
K.18.30.ST	(10+10) X 25 X 45	4 - 8 - 12
K.18.35.ST	(10+10) X 25 X 45	4 - 8 - 12
K.18.40.ST	(10+10) X 25 X 45	4 - 8 - 12
K.20.28.ST	(8+8) X 32 X 45	4 - 8 - 12
K.20.40.ST	(8+8) X 32 X 45	4 - 8 - 12
K.20.45.ST	(8+8) X 32 X 45	4 - 8 - 12
K.20.60.ST	(8+8) X 32 X 45	4 - 8 - 12
<u>YG Series</u>		
Y.09.09.ST.	8 X 16 X 25	2
Y.11.08.ST.	10 X 20 X 27	2
Y.11.15.ST.	10 X 20 X 27	2
Y.13.15.ST.	12.5 X 20 X 40	2 - 4
<u>SL Series</u>		
S.08.05.ST.		
S.08.08.ST.	depends on the	
S.08.10.ST.	applied voltage	consult Femsan
S.08.15.ST.		
S.11.07.ST.		
S.11.11.ST.		
S.11.15.ST.		
<u>DV Series</u>		
D.09.09.ST.	8 X 16 X 25	2 - 4
D.11.07.ST.	10 X 20 X 27	2 - 4
D.11.08.ST.	10 X 20 X 27	2 - 4
D.11.09.ST.	10 X 20 X 27	2 - 4
D.13.08.ST.	12.5 X 20 X 40	2 - 4

**6.2. COMMUTATOR**

A commutation track dark brown color, uniform and glossy, is an indication of good operating of motor. On the other hand, if the tracks shows black stains, unevenness or burnings it must be cleaned. Besides that, the commutator ovalization must be checked, if necessary the commutator must be turned.

**WARNING !**

*Turning must be carried out by expert personnel.*

**6.3. BEARINGS**

In every 2000 working hours it is advisable to check the temperatures and the vibrations of the bearings. When replacing the bearings take care not to damage the bearing seat on the motor shaft. The bearings must be removed using an extractor and placed by heat. Make sure that the bearing is firmly locked in place.

**Table 2.**

Table of Bearing		
Type	<u>Coupling Side</u>	<u>Commutator Side</u>
KG Series		
K.08.07.ST	6205 2RS C3	6204 2RS
K.08.10.ST	6205 2RS C3	6204 2RS
K.09.15.ST	6205 2RS C3	6204 2RS
K.09.20.ST	6206 2RS C3	6204 2RS
K.09.25.ST	6206 2RS C3	6204 2RS
K.10.10.ST	6208 2RS C3	6306 2RS
K.10.14.ST	6208 2RS C3	6306 2RS
K.10.23.ST	6208 2RS C3	6306 2RS
K.10.28.ST	6208 2RS C3	6306 2RS
K.13.12.ST.	6310 2RS C3	6209 2RS
K.13.16.ST.	6310 2RS C3	6209 2RS
K.13.20.ST.	6310 2RS C3	6209 2RS
K.13.25.ST.	6310 2RS C3	6209 2RS
K.13.30.ST.	6310 2RS C3	6209 2RS
K.16.13.ST	6310 2RS C3	6309 2RS
K.16.18.ST	6312 2RS C3	6309 2RS
K.16.26.ST	6312 2RS C3	6309 2RS
K.16.30.ST	6312 2RS C3	6309 2RS
K.16.40.ST	6312 2RS C3	6309 2RS
K.18.30.ST	NU 213	6213 2RS
K.18.35.ST	NU 213	6213 2RS
K.18.40.ST	NU 213	6213 2RS
K.20.28.ST	NU 314	6314 2RS
K.20.40.ST	NU 314	6314 2RS
K.20.45.ST	NU 314	6314 2RS
K.20.60.ST	NU 314	6314 2RS
YG Series		
Y.09.09.ST.	6205 2RS C3	6204 2RS
Y.11.08.ST.	6205 2RS C3	6204 2RS
Y.11.15.ST.	6205 2RS C3	6204 2RS
Y.13.15.ST.	6207 2RS C3	6206 2RS
SL Series		
S.08.05.ST.	6204 2RSC3	6203 2RS C3
S.08.08.ST.	6204 2RS C3	6203 2RS C3
S.08.10.ST.	6204 2RS C3	6203 2RS C3
S.08.15.ST.	6204 2RS C3	6203 2RS C3
S.11.07.ST.	6206 2 RS C3	6206 2RS

S.11.11.ST.	6206 2 RS C3	6206 2RS
S.11.15.ST.	6206 2 RS C3	6206 2RS
DV Series		
D.09.09.ST.	6205 2RS C3	6204 2RS
D.11.07.ST.	6205 2RS C3	6204 2RS
D.11.08.ST.	6205 2RS C3	6204 2RS
D.11.09.ST.	6205 2RS C3	6204 2RS
D.13.08.ST.	6207 2RS C3	6206 2RS

#### 6.4. Insulation Resistance Measurement

**WARNING !**

*Before performing this measurement, disconnect DC driver from DC motor.*

Insulation resistance measurement should preferably be done by using a 500 V. Megger. The reading should be taken after one minute of continuous application of test voltage. The minimum recommended value referred to 40 °C ambient temperature is 1.5 Ω for both stator and armature windings.

#### 6.5. Windings Cleaning

Many more failures are caused by moisture and contaminants. Contaminants and oily vapors have good electrical conductivity and cause leakage currents from windings to ground or between windings. Cleanliness of windings and commutator is therefore very important to ensure a long trouble free life to the motors

### POSSIBLE MALFUNCTIONS

PROBLEM	CAUSE	SOLUTION
Vibration when the motor is coupled	Excessive belt tension	Loosen the belt, fit a belt stretcher if necessary.
	Defective balancing of the coupled machine; coupling device out of balance	Check balancing
	Defective alignment (see figure 2)	Check coupling
Vibration when the motor is not coupled	Defective bearings	Replace bearings
	Coupling device out of balance	Balance the motor with pulley
Hissing bearing	Lack of grease; defective bearing	Lubricate or replace bearing
Excessive bearing wear	Overloaded bearing	Check radial load and the coupling device; eliminate the axial loads
The motor does not start at no load	The main field is open	Rewind main field
	The armature coils are in short circuited	Repair or rewind the armature
	Poor contact between brushes and commutator	Check the brushes and replace the worn ones
The motor runs unevenly	The armature coils are in short circuited	Repair or rewind the armature
	Commutator segments short circuited	Remove the short circuit. Remove the mica insulation between the segments
The motor does not start when coupled	Overload	Check load current
	The brushes are out of the neutral zone	Reset the neutral position
Overheating	Overload	Check voltage, armature current and excitation current
	Poor ventilation	Check filter clogging
	Commutator inspection doors are open or not closed properly	Tighten the covers
	Check power supply for possible need of choke coil ; wrong choke coil	Connect or replace the choke coil