

# "ECOL" Motors in Cast Iron Housing

## FEATURES

- Energy savings, high efficiency
- High starting torque, lower starting current
- Versatile and easy to modify design adapts to a variety of applications
- Option of integrated or removable feet
- Option of terminal box location (top, left or right)
- Option of IE2, IE3, MEPS High and Premium Efficiency for IEC standards + NEMA EPACT and Premium Efficiency
- Contained total length is the same as or shorter than the current market standard
- Full use of the magnetization properties of cold rolled silicone steel in which the stator laminations are magnetized evenly to reduce temperature rise of the winding



## APPLICATIONS

- Pumps
- Waste water treatment plants
- Air compressors, fans
- Gear reducers and power transmission
- Pulp and paper mills
- Steel mill
- Conveyors, elevators
- Should be "Material handling equipment"
- Agricultural application
- Mining equipment
- Hydraulic equipment

# Motor Spare Part List "Exploded Drawing"

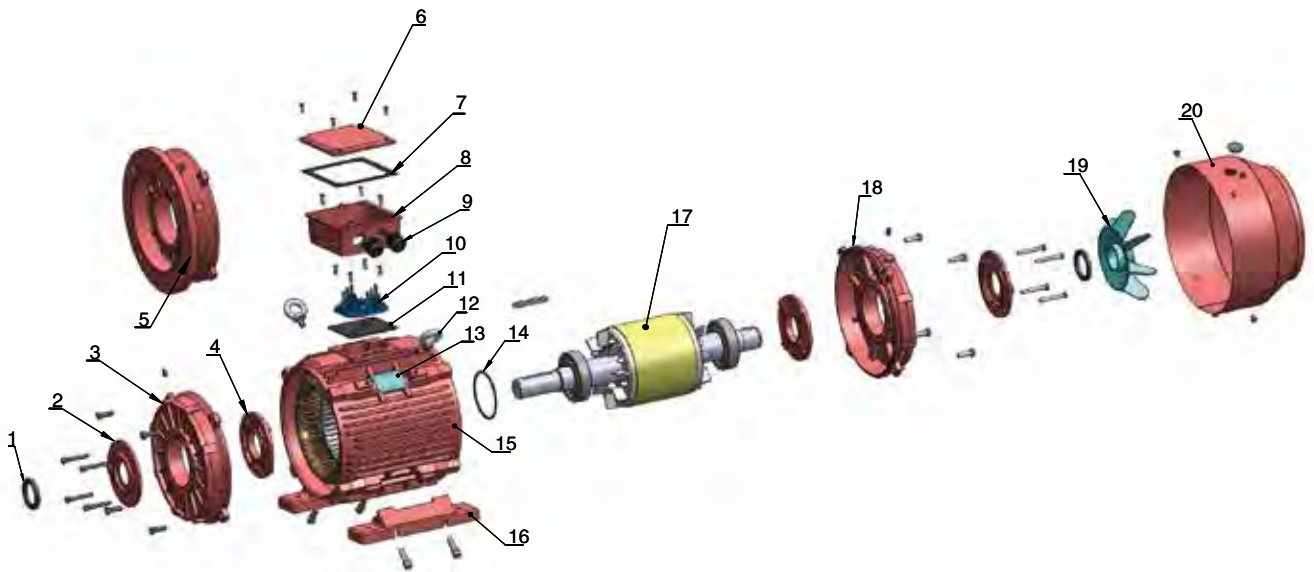

- |                          |                    |                      |                   |
|--------------------------|--------------------|----------------------|-------------------|
| 1. Oil seal              | 6. TB cover        | 11. TB bottom gasket | 16. Foot          |
| 2. Outer bearing cap D.E | 7. TB upper gasket | 12. Eye bolt         | 17. Rotor         |
| 3. DE endshield          | 8. TB base         | 13. Nameplate        | 18. NDE endshield |
| 4. Inner bearing cap D.E | 9. Cable gland     | 14. Wave washer      | 19. Cooling fan   |
| 5. B5 flange             | 10. Terminal board | 15. Frame            | 20. Fan cover     |

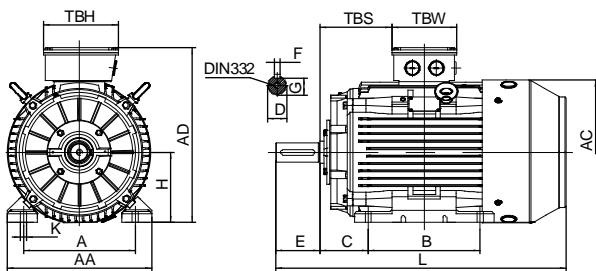

IM B3

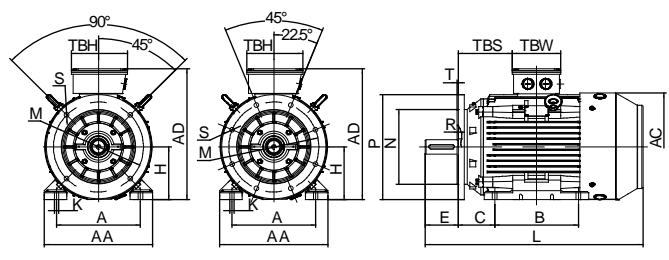

IM B35

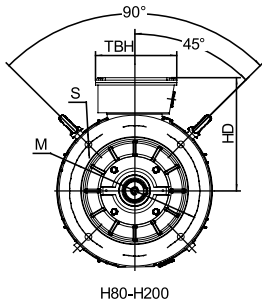

H80-H200

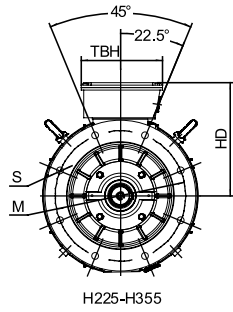

H225-H355

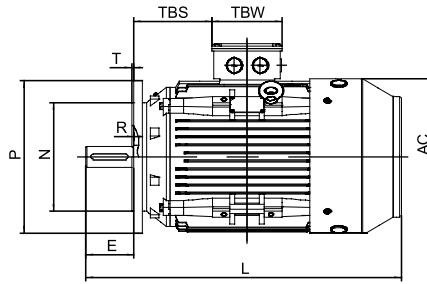

IM B5

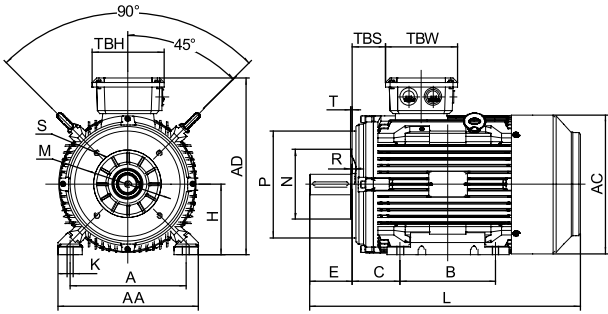

IM B34

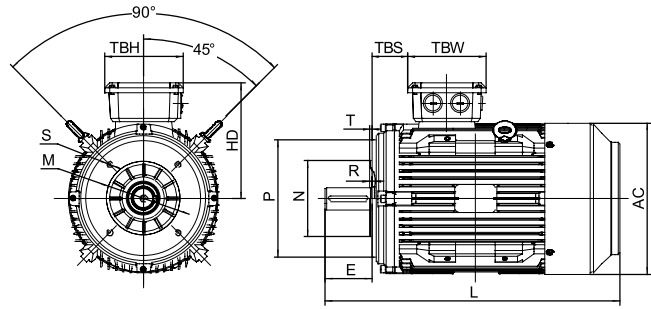

IM B14

## Overall & Installation Dimensions

Frame	Foot Mounting				Shaft						General							
	H	A	B	C	D	E	F	G	K	AA	AD	HD	AC	L	TBS	TBW	TBH	
80	80	125	100	50	φ 19	40	6	15.5	φ 9	154	214	134	φ 158	290	43	114	114	
90S/L	90	140	100/125	56	φ 24	50	8	20	φ 10	178	231	141	φ 176	320/345	49/61.5	114	114	
100L	100	160	140	63	φ 28	60	8	24	φ 12	203	251	151	φ 199	385	76	114	114	
112M	112	190	140	70	φ 28	60	8	24	φ 12	231	292	180	φ 220	405	73	134	134	
132S/M	132	216	140/178	89	φ 38	80	10	33	φ 12	263	332	200	φ 259	467/505	61.5	134	134	
160M/L	160	254	210/254	108	φ 42	110	12	37	φ 15	316	404	244	φ 313	605/650	91	162	187	
180M/L	180	279	241/279	121	φ 48	110	14	42.5	φ 15	354	445	265	φ 360	687/725	160/180	162	187	
200L	200	318	305	133	φ 55	110	16	49	φ 19	393	500	300	φ 399	768.5	192	186	233	
225S	4,6,8	225	356	286	149	φ 60	140	18	53	φ 19	440	558	333	φ 459	810	199	186	233
	2	225	356	311	149	φ 55	110	16	49	φ 19	440	558	333	φ 459	805	211.5	186	233
225M	4,6,8	225	356	311	149	φ 60	140	18	53	φ 19	440	558	333	φ 459	835	211.5	186	233
	2	250	406	349	168	φ 60	140	18	53	φ 24	484	616	366	φ 506	915	233	218	260
250M	4,6,8	250	406	349	168	φ 65	140	18	58	φ 24	484	616	366	φ 506	915	233	218	260
	2	280	457	368/419	190	φ 65	140	18	58	φ 24	560	675	395	φ 559	984/1035	265/277	218/245	260/280
280S/M	4,6,8	280	457	368/419	190	φ 75	140	20	67.5	φ 24	560	675	395	φ 559	984/1035	265/277	218/245	260/280
	2	315	508	406	216	φ 65	140	18	58	φ 28	628	825	510	φ 680	1205	200	290	350
315S	4,6,8	315	508	406	216	φ 80	170	22	71	φ 28	628	825	510	φ 680	1235	200	290	350
	2	315	508	457/508	216	φ 65	140	18	58	φ 28	628	825	510	φ 680	1355	200	290	350
315M/L	4,6,8	315	508	457/508	216	φ 80	170	22	71	φ 28	628	825	510	φ 680	1385	200	290	350
	2	355	610	560/630	254	φ 75	140	20	67.5	φ 28	740	1010	655	φ 820	1495	140	330	380
355M/L	4,6,8	355	610	560/630	254	φ 95	170	25	86	φ 28	740	1010	655	φ 820	1525	140	330	380
	4,6,8	355	610	560/630	254	φ 100	210	28	90	φ 28	740	1010	655	φ 820	1565	140	330	380

Frame	Bearings		Cable Gland	B5						B14					
	DE	NDE		N	M	P	S	T	R	N	M	P	S	T	R
80	6204		1-M20×1.5	φ 130	φ 165	φ 200	4×φ 12	3.5	0	φ 80	φ 100	φ 120	M6	3	0
90S/L	6205		1-M20×1.5	φ 130	φ 165	φ 200	4×φ 12	3.5	0	95	115	140	M8	3	0
100L	6206		1-M20×1.5	φ 180	φ 215	φ 250	4×φ 15	4	0	110	130	160	M8	3.5	0
112M	6306		2-M25×1.5	φ 180	φ 215	φ 250	4×φ 15	4	0	110	130	160	M8	3.5	0
132S/M	6308		2-M25×1.5	φ 230	φ 265	φ 300	4×φ 15	4	0	130	165	200	M10	3.5	0
160M/L	6309		2-M32×1.5	φ 250	φ 300	φ 350	4×φ 19	5	0	180	215	250	M12	5	0
180M/L	6311		2-M32×1.5	φ 250	φ 300	φ 350	4×φ 19	5	0						
200L	6312		2-M40×1.5	φ 300	φ 350	φ 400	4×φ 19	5	0						
225S/M	6313		2-M50×1.5	φ 350	φ 400	φ 450	8×φ 19	5	0						
250M	6314		2-M50×1.5	φ 450	φ 500	φ 550	8×φ 19	5	0						
280S/M	6316		2-M50×1.5	φ 450	φ 500	φ 550	8×φ 19	5	0						
315S/M/L	2	6317		2-M63×1.5	φ 550	φ 600	φ 660	8×φ 24	6	0					
	4,6,8	NU319	6319												
355M/L	2	6319		2-M63×1.5	φ 680	φ 740	φ 800	8×φ 24	6	0					
	4,6,8	NU322	6322												

# T1C Series IE1 Efficiency Motors Technical Data (400V/50Hz)

Model	Output (kW)	Rated current (A)	Rotation speed (r/min)	Efficiency 100% load (%)	Efficiency 75% load (%)	Efficiency 50% load (%)	Power factor (Φ)	Rated torque (N.m)	T <sub>es</sub> /T <sub>n</sub> (Times)	T <sub>min</sub> /T <sub>n</sub> (Times)	T <sub>max</sub> /T <sub>n</sub> (Times)	I <sub>st</sub> /I <sub>n</sub> (Times)	Nosie (dB)	Net weight (kg)	Moment of inertia(kg·m <sup>2</sup> )
T1C 801-2	0.75	2.06	2840	72.1	73.3	69.0	0.73	2.52	2.2	1.8	2.3	6	67	14.3	0.00093
T1C 802-2	1.1	2.90	2840	75	77.7	74.8	0.73	3.70	2.2	1.8	2.3	7	67	16.0	0.00110
T1C 90S-2	1.5	3.79	2840	77.2	78.5	75.1	0.74	5.04	2.2	1.8	2.3	7	72	18.5	0.00184
T1C 90L-2	2.2	5.04	2840	79.7	80.9	78.8	0.79	7.40	2.2	1.8	2.3	7.5	72	22.0	0.00239
T1C 100L-2	3	6.56	2840	81.5	82.8	80.1	0.81	10.09	2.2	1.8	2.3	7.5	76	32.0	0.00368
T1C 112M-2	4	8.58	2900	83.1	84.9	82.6	0.81	13.17	2.2	1.8	2.3	7.5	77	41.0	0.01613
T1C 132S1-2	5.5	11.16	2900	84.7	85.5	82.8	0.84	18.11	2.2	1.8	2.3	7.5	80	57.5	0.01106
T1C 132S2-2	7.5	14.81	2900	86	87.1	84.7	0.85	24.70	2.2	1.8	2.3	7.5	80	62.0	0.01468
T1C 132M1-2	9.2	17.75	2900	87	88.2	86.1	0.86	30.30	2.2	1.4	2.3	7.5	80	68.5	0.01767
T1C 160M1-2	11	20.14	2945	87.6	88.9	86.6	0.90	35.67	2.2	1.4	2.3	8.5	86	111.0	0.04150
T1C 160M2-2	15	27.74	2945	88.7	90.0	88.1	0.88	48.64	2.2	1.4	2.3	9	86	122.0	0.05384
T1C 160L-2	18.5	35.18	2945	89.3	91.0	89.5	0.85	59.99	2.2	1.4	2.3	10	86	140.0	0.06436
T1C 180M-2	22	39.25	2945	89.9	89.9	87.6	0.90	71.34	2.2	1.3	2.3	8	89	153.0	0.08110
T1C 200L1-2	30	53.0	2950	90.7	91.4	89.7	0.90	97.12	2.0	1.3	2.3	7.5	92	218.0	0.15138
T1C 200L2-2	37	65.1	2950	91.2	92.7	91.5	0.90	119.8	2.0	1.3	2.3	7.5	92	230.0	0.17351
T1C 225M-2	45	78.7	2955	91.7	91.4	89.7	0.90	145.4	2.0	1.3	2.3	7.5	92	303.0	0.24178
T1C 250M-2	55	95.8	2970	92.1	92.5	90.7	0.90	176.9	2.0	1.3	2.3	9	93	391.0	0.38903
T1C 280S-2	75	129.7	2970	92.7	92.9	91.1	0.90	241.2	2.0	1.3	2.3	9	94	530.0	0.69871
T1C 280M-2	90	155.2	2970	93	92.8	90.9	0.90	289.4	2.0	1.3	2.3	9	94	572.0	0.79539
T1C 315S-2	110	189.1	2970	93.3	94.0	92.5	0.90	353.7	2.0	1.5	2.2	7	96	900.0	1.41216
T1C 315M-2	132	223.9	2970	93.5	94.1	92.8	0.91	424.4	2.0	1.5	2.2	7	96	970.0	1.55013
T1C 315L1-2	160	273.6	2970	93.8	94.2	93.0	0.90	514.5	2.0	1.5	2.2	7	99	1010.0	1.71199
T1C 315L2-2	200	341.2	2970	94	94.3	93.1	0.90	643.1	2.0	1.5	2.2	7	99	1070.0	1.90623
T1C 355M1-2	220	375.3	2980	94	94.3	93.1	0.90	705.0	2.0	1.2	2.2	7	103	1590.0	2.95585
T1C 355M2-2	250	426.5	2980	94	94.4	93.2	0.90	801.2	2.0	1.2	2.2	7	103	1650.0	3.14272
T1C 355L1-2	280	477.7	2980	94	94.5	93.2	0.90	897.3	2.0	1.2	2.2	7	103	1715.0	3.47911
T1C 355L2-2	315	537.4	2980	94	94.5	93.2	0.90	1009.5	2.0	1.2	2.2	7	103	1780.0	3.85287
T1C 801-4	0.55	1.51	1420	70	72.5	70.2	0.75	3.70	2.3	2.0	2.6	6	58	13.5	0.00141
T1C 802-4	0.75	2.00	1420	72.1	79.2	76.8	0.75	5.04	2.3	2.0	2.6	6	58	14.6	0.00168
T1C 90S-4	1.1	2.82	1430	75	77.8	74.5	0.75	7.35	2.3	2.0	2.6	6.5	61	18.0	0.00238
T1C 90L-4	1.5	3.69	1430	77.2	80.0	77.3	0.76	10.02	2.3	2.0	2.6	6.5	61	23.0	0.00335
T1C 100L1-4	2.2	4.98	1430	79.7	79.3	75.6	0.80	14.69	2.2	2.0	2.6	6.5	64	32.0	0.00688
T1C 100L2-4	3	6.64	1435	81.5	82.6	79.9	0.80	19.97	2.2	2.0	2.6	7.5	64	35.0	0.00883
T1C 112M-4	4	8.47	1435	83.1	86.2	84.7	0.82	26.62	2.2	2.0	2.6	7.5	65	44.0	0.01311
T1C 132S-4	5.5	11.29	1440	84.7	87.5	85.6	0.83	36.48	2.2	1.6	2.6	7.5	71	61.0	0.02679
T1C 132M-4	7.5	14.81	1440	86	88.6	86.9	0.85	49.74	2.2	1.6	2.6	7.5	71	76.0	0.03694
T1C 132M2-4	9.2	18.17	1440	86	88.6	85.8	0.85	61.01	2.2	1.6	2.6	7.5	71	79.0	0.04412
T1C 160M-4	11	21.58	1465	87.6	89.7	88.8	0.84	71.71	2.2	1.6	2.6	8.5	75	115.0	0.07659
T1C 160L-4	15	28.06	1465	88.7	90.2	88.7	0.87	97.78	2.2	1.6	2.6	8	75	137.0	0.10379
T1C 180M-4	18.5	33.98	1465	89.3	90.6	89.3	0.88	120.6	2.2	1.6	2.6	8	76	149.5	0.14084
T1C 180L-4	22	40.14	1465	89.9	90.7	89.3	0.88	143.4	2.2	1.6	2.6	8	76	165.0	0.16541
T1C 200L-4	30	56.16	1475	90.7	92.3	91.6	0.85	194.2	2.2	1.6	2.6	8	79	216.5	0.26594
T1C 225S-4	37	68.9	1480	91.2	90.9	88.8	0.85	238.8	2.2	1.3	2.6	7	81	293.0	0.50439
T1C 225M-4	45	83.3	1480	91.7	92.6	91.0	0.85	290.4	2.2	1.3	2.6	7	81	335.0	0.57909
T1C 250M-4	55	100.2	1480	92.1	92.4	90.7	0.86	354.9	2.2	1.3	2.6	8	83	397.0	0.69098
T1C 280S-4	75	131.2	1480	92.7	93.1	93.2	0.89	484.0	2.2	1.3	2.6	9	86	540.0	1.41285
T1C 280M-4	90	155.2	1480	93	93.4	93.5	0.90	580.7	2.2	1.3	2.6	9	86	620.0	1.74607
T1C 315S-4	110	189.1	1480	93.3	93.8	93.2	0.90	709.8	2.0	1.3	2.3	7	93	915.0	2.90486
T1C 315M-4	132	226.4	1480	93.5	94.0	93.6	0.90	851.8	2.0	1.3	2.3	7	93	1005.0	3.29579
T1C 315L1-4	160	273.6	1480	93.8	94.0	93.5	0.90	1032.4	2.0	1.3	2.3	7	97	1068.0	3.73367
T1C 315L2-4	200	341.2	1480	94	94.3	93.9	0.90	1290.5	2.0	1.3	2.3	7	97	1210.0	4.67201
T1C 355M1-4	220	379.6	1480	94	94.5	94.0	0.89	1419.6	2.0	1.2	2.3	7	101	1560.0	6.87200
T1C 355M2-4	250	431.3	1480	94	94.5	94.0	0.89	1613.2	2.0	1.2	2.3	7	101	1600.0	7.63820
T1C 355L1-4	280	483.1	1480	94	94.5	94.0	0.89	1806.8	2.0	1.2	2.3	7	101	1650.0	8.31927
T1C 355L2-4	315	537.4	1485	94	94.6	94.1	0.90	2025.8	2.0	1.2	2.3	7	101	1700.0	9.08547
T1C 355L3-4	355	605.7	1485	94	94.6	94.1	0.90	2283.0	2.0	1.2	2.3	7	101	1780.0	10.10708

# T1C Series IE1 Efficiency Motors Technical Data (400V/50Hz)

Model	Output (kW)	Rated current (A)	Rotation speed (r/min)	Efficiency 100% load (%)	Efficiency 75% load (%)	Efficiency 50% load (%)	Power factor (Φ)	Rated torque (N.m)	T <sub>s</sub> /T <sub>n</sub> (Times)	T <sub>min</sub> /T <sub>n</sub> (Times)	T <sub>max</sub> /T <sub>n</sub> (Times)	I <sub>a</sub> /I <sub>n</sub> (Times)	Noise (dB)	Net weight (kg)	Moment of inertia(kg·m <sup>2</sup> )
T1C 801-6	0.37	1.49	900	59.7	60.5	55.7	0.60	3.93	2.0	1.8	2.2	5.5	54	14.0	0.00231
T1C 802-6	0.55	1.95	900	65.8	66.1	62.3	0.62	5.84	2.0	1.8	2.2	5.5	54	15.0	0.00284
T1C 90S-6	0.75	2.34	935	70	70.4	65.8	0.66	7.66	2.0	1.8	2.2	5.5	57	19.0	0.00335
T1C 90L-6	1.1	3.20	935	72.9	74.2	70.8	0.68	11.24	2.0	1.8	2.2	5.5	57	21.6	0.00461
T1C 100L-6	1.5	3.94	940	75.2	75.7	72.4	0.73	15.24	2.0	1.8	2.2	5.5	61	29.5	0.00783
T1C 112M-6	2.2	5.68	940	77.7	79.3	76.2	0.72	22.35	2.0	1.8	2.2	6	65	38.0	0.01383
T1C 132S-6	3	7.24	940	79.7	80.2	76.8	0.75	30.48	2.0	1.8	2.2	6	69	49.6	0.02855
T1C 132M1-6	4	9.58	950	81.4	82.8	80.1	0.74	40.21	2.0	1.8	2.5	6	69	59.4	0.03601
T1C 132M2-6	5.5	12.91	950	83.1	83.0	80.6	0.74	55.29	2.0	1.8	2.5	7.5	69	65.0	0.04890
T1C 160M-6	7.5	16.82	965	84.7	87.0	85.2	0.76	74.22	2.0	1.3	2.5	7.5	73	112.0	0.08726
T1C 160L-6	11	24.18	970	86.4	86.7	84.4	0.76	108.3	2.0	1.3	2.5	7.5	73	122.4	0.10963
T1C 180L-6	15	29.74	970	87.7	89.1	87.8	0.83	147.7	1.8	1.2	2.2	8	73	161.5	0.24936
T1C 200L1-6	18.5	34.25	970	88.6	90.9	90.3	0.88	182.1	1.8	1.2	2.2	8	76	208.3	0.36147
T1C 200L2-6	22	40.45	970	89.2	91.0	90.5	0.88	216.6	1.8	1.2	2.2	8	76	218.2	0.39445
T1C 225M-6	30	55.2	975	90.2	91.2	89.9	0.87	293.8	1.8	1.2	2.2	7	76	289.0	0.55616
T1C 250M-6	37	70.0	980	90.8	90.7	88.6	0.84	360.6	2.0	1.3	2.2	7.5	78	380.0	0.96477
T1C 280S-6	45	83.6	980	91.4	92.6	91.6	0.85	438.5	2.0	1.3	2.2	7.5	80	489.5	1.68116
T1C 280M1-6	55	100.4	980	91.9	93.3	92.5	0.86	536.0	2.0	1.3	2.2	7.5	80	560.0	1.99928
T1C 315S-6	75	135.9	985	92.6	93.4	92.2	0.86	727.2	2.0	1.3	2.3	7	85	806.0	3.25976
T1C 315M-6	90	162.6	985	92.9	93.5	92.5	0.86	872.6	2.0	1.3	2.3	7	85	912.0	3.90933
T1C 315L1-6	110	197.9	985	93.3	93.5	92.3	0.86	1066.5	2.0	1.3	2.3	7	85	965.0	4.54331
T1C 315L2-6	132	236.9	985	93.5	93.6	92.5	0.86	1279.8	2.0	1.3	2.3	7	85	1070.0	5.44899
T1C 355M1-6	160	276.6	990	93.8	93.5	92.7	0.89	1543.4	2.0	1.2	2.2	8	92	1537.0	8.97637
T1C 355M2-6	200	341.2	990	94	93.5	92.8	0.90	1929.3	2.0	1.2	2.2	8	92	1720.0	11.00175
T1C 355L-6	250	426.5	990	94	93.6	92.8	0.90	2411.6	2.0	1.2	2.2	8	92	1880.0	13.56011
T1C 801-8	0.18	0.8	680	51	52.5	48.5	0.61	3.5	1.5	1.3	1.7	2.8	52	15	0.00214
T1C 802-8	0.25	1.1	680	56	58.2	52.5	0.61	3.5	1.6	1.3	2	2.7	52	16.1	0.00249
T1C 90S-8	0.37	1.3	680	63	63.8	58.5	0.63	5.2	1.6	1.3	1.8	2.8	56	19.2	0.00335
T1C 90L-8	0.55	1.9	680	66	67.2	62.3	0.65	7.7	1.6	1.3	1.8	3	56	21.8	0.00461
T1C 100L1-8	0.75	2.4	710	66	67.5	62.5	0.67	10.1	1.7	1.3	2.1	3.5	59	27.9	0.00688
T1C 100L2-8	1.1	3.2	710	72	72.8	67.7	0.69	14.8	1.7	1.3	2.1	3.5	59	32	0.00925
T1C 112M-8	1.5	4.3	710	74	73.2	68.6	0.68	20.2	1.8	1.2	2.1	4.2	61	39.1	0.01552
T1C 132S-8	2.2	6.0	720	75	75.5	71.1	0.71	29.2	2	1.2	2	5.5	64	58	0.03408
T1C 132M-8	3	7.7	720	77	77.2	72.6	0.73	39.8	2	1.2	2	5.5	64	64	0.04522
T1C 160M1-8	4	11.1	730	80	79.5	75.6	0.65	52.33	1.6	1.2	2.2	6	68	108	0.07620
T1C 160M2-8	5.5	14.63	730	83.5	81.6	77.7	0.65	71.95	1.6	1.2	2.2	6	68	124	0.09095
T1C 160L-8	7.5	19.6	730	85	82.8	79.5	0.65	98.12	1.6	1.2	2.2	6	68	136	0.10594
T1C 180L-8	11	24.1	730	88	87.3	84.9	0.75	143.9	2	1.4	2	6	70	174	0.25695
T1C 200L-8	15	29.7	730	89	89.3	88	0.82	196.2	1.6	1.3	2.2	7	73	220	0.36147
T1C 225S-8	18.5	37.1	735	90	88.8	87.2	0.80	240.4	1.6	1.3	2	6	73	285	0.49078
T1C 225M-8	22	43.9	735	90.5	90.4	89.1	0.80	285.9	1.6	1.3	2	6	73	310	0.58885
T1C 250M-8	30	59.5	735	91	91.9	90.8	0.80	389.8	1.6	1.0	1.8	6	75	395	1.02008
T1C 280S-8	37	74.8	740	91.5	91.2	90.5	0.78	477.5	1.9	1.2	2	6.5	76	523	1.88979
T1C 280M-8	45	90.5	740	92	92.3	90.8	0.78	580.7	1.9	1.2	2	6.5	76	575	2.26008
T1C 315S-8	55	106.9	740	92.8	92.5	91.2	0.80	709.8	2	1.3	2	6.5	82	842	3.89374
T1C 315M-8	75	145.5	740	93	92.6	91.1	0.80	967.9	2	1.3	2	6.5	82	998.8	5.26785
T1C 315L1-8	90	173.1	740	93.8	93.9	92.3	0.80	1161.5	2	1.3	2	6.5	82	1096.8	6.26411
T1C 315L2-8	110	211.1	740	94	93.2	92.2	0.80	1419.6	2	1.3	2	6.5	82	1191.2	7.44150
T1C 355M1-8	132	254.2	740	93.7	93.6	92.5	0.80	1703.5	1.8	1.3	2	6.5	90	1496.8	8.86978
T1C 355M2-8	160	306.4	740	94.2	93.6	92.3	0.80	2064.9	1.8	1.3	2	6.5	90	1592	10.04236
T1C 355L-8	200	381.8	740	94.5	93.1	92.5	0.80	2581.1	1.8	1.3	2	6.5	90	1752	12.28093

# T3C Series IE3 Efficiency Motors Technical Data (400V/50Hz)

Model	Output (kW)	Rated current (A)	Rotation speed (r/min)	Efficiency 100% load (%)	Efficiency 75% load (%)	Efficiency 50% load (%)	Power factor (Φ)	Rated torque (N.m)	T <sub>st</sub> /T <sub>n</sub> (Times)	T <sub>min</sub> /T <sub>n</sub> (Times)	T <sub>max</sub> /T <sub>n</sub> (Times)	I <sub>st</sub> /I <sub>n</sub> (Times)	Nosie (dB)	Net weight (kg)	Moment of inertia (kg·m <sup>2</sup> )
T3C 801-2	0.75	1.68	2880	80.7	81.0	76.2	0.80	2.49	2.5	2.1	2.8	7.5	67	15.20	0.00093
T3C 802-2	1.1	2.40	2880	82.7	83.5	81.6	0.80	3.65	2.5	1.8	2.8	8	67	17.10	0.00128
T3C 90S-2	1.5	3.06	2880	84.2	84.9	84.0	0.84	4.97	2.5	1.8	2.8	8.5	72	21.5	0.00224
T3C 90L-2	2.2	4.45	2880	85.9	86.4	84.7	0.83	7.30	2.5	1.8	2.8	8.6	72	24.6	0.00279
T3C 100L-2	3	5.65	2900	87.1	88.5	86.8	0.88	9.88	2.5	2.0	2.8	9.5	76	35.5	0.00496
T3C 112M-2	4	7.28	2910	88.1	88.5	87.1	0.90	13.13	2.5	2.0	2.8	10.5	77	44.5	0.00744
T3C 132S1-2	5.5	10.11	2910	89.2	90.2	88.6	0.88	18.05	2.5	2.0	3.0	10	80	63.2	0.01468
T3C 132S2-2	7.5	13.50	2920	90.1	90.8	89.3	0.89	24.53	2.5	1.5	3.0	10	80	70.2	0.01903
T3C 132M1-2	9.2	16.47	2920	90.6	91.2	89.5	0.89	30.09	2.5	1.5	3.0	10	80	76.8	0.02048
T3C 160M1-2	11	19.34	2930	91.2	93.8	93.0	0.90	35.85	2.5	1.4	3.0	9.5	86	118.0	0.05178
T3C 160M2-2	15	26.18	2940	91.9	93.1	92.9	0.90	48.72	2.5	1.4	3.0	10	86	128.0	0.06206
T3C 160L-2	18.5	31.76	2940	92.4	93.5	93.3	0.91	60.09	2.5	1.4	3.0	9.5	86	144.00	0.07669
T3C 180M-2	22	38.5	2945	92.7	94.1	93.6	0.89	71.34	2.5	1.4	3.0	9	89	183.40	0.09665
T3C 200L1-2	30	52.1	2945	93.3	93.8	93.2	0.89	97.3	2.5	1.5	2.5	8.5	92	247.00	0.17351
T3C 200L2-2	37	64.0	2945	93.7	94.4	94.2	0.89	120.0	2.5	1.5	2.5	8.5	92	268.00	0.20008
T3C 225M-2	45	75.9	2950	94	94.6	94.1	0.91	145.7	2.5	1.4	2.5	8.5	92	369.00	0.34366
T3C 250M-2	55	93.5	2960	94.3	94.5	93.1	0.90	177.4	2.5	1.4	2.6	10	93	428.00	0.44434
T3C 280S-2	75	125.6	2960	94.7	94.9	93.7	0.91	242.0	2.5	1.8	2.6	10	94	587.30	0.82911
T3C 280M-2	90	150.3	2960	95	95.2	94.3	0.91	290.4	2.5	1.8	2.6	10	94	655.00	0.98168
T3C 315S-2	110	185.3	2960	95.2	95.5	94.6	0.90	354.9	2.0	1.4	2.3	7	96	980.00	1.70352
T3C 315M-2	132	221.9	2960	95.4	95.5	94.7	0.90	425.9	2.0	1.4	2.3	7	96	1100.00	1.93860
T3C 315L1-2	160	267.8	2960	95.8	95.8	94.5	0.90	516.2	2.0	1.4	2.3	7	99	1155.00	2.19758
T3C 315L2-2	200	334.8	2960	95.8	96.0	94.7	0.90	645.3	2.0	1.4	2.3	7	99	1260.00	2.55368
T3C 355M1-2	220	394.6	2960	95.8	96.2	94.8	0.84	709.8	2.0	1.5	2.3	6.5	103	1590.00	2.95585
T3C 355M2-2	250	448.4	2960	95.8	96.2	94.8	0.84	806.6	2.0	1.5	2.3	6.5	103	1650.00	3.14272
T3C 355L1-2	280	502.2	2960	95.8	96.2	94.8	0.84	903.4	2.0	1.5	2.3	6.5	103	1715.00	3.47911
T3C 355L2-2	315	558.3	2960	95.8	96.2	94.8	0.85	1016.3	2.0	1.5	2.3	6.5	103	1780.00	3.85287
T3C 802-4	0.75	1.90	1420	82.5	82.8	80.6	0.69	5.04	2.8	2.2	2.8	6.3	58	18.20	0.00155
T3C 90S-4	1.1	2.62	1430	84.1	84.6	83.2	0.72	7.35	2.8	2.2	2.8	6.8	61	23.00	0.00372
T3C 90L-4	1.5	3.63	1430	85.3	86.1	85.2	0.70	10.02	2.8	2.2	3.0	7.3	61	26.30	0.00469
T3C 100L1-4	2.2	4.52	1430	86.7	87.8	85.2	0.81	14.69	2.8	2.2	3.0	8	64	35.50	0.00922
T3C 100L2-4	3	6.33	1435	87.7	88.0	85.9	0.78	19.97	2.5	2.2	3.0	8.2	64	38.50	0.01195
T3C 112M-4	4	7.95	1440	88.6	88.9	87.5	0.82	26.53	2.5	2.2	3.0	8.6	65	47.00	0.01545
T3C 132S-4	5.5	10.67	1440	89.6	90.9	88.9	0.83	36.48	2.5	1.8	3.0	9	71	68.30	0.03397
T3C 132M-4	7.5	14.09	1440	90.4	91.3	91.2	0.85	49.74	2.5	1.6	3.0	9	71	79.00	0.04412
T3C 132M2-4	9.2	17.19	1440	90.9	91.8	90.5	0.85	61.01	2.5	1.6	3.0	9	71	87.50	0.04700
T3C 160M-4	11	20.68	1450	91.4	92.2	91.7	0.84	72.45	2.5	1.3	3.0	10	75	127.00	0.10355
T3C 160L-4	15	27.33	1450	92.1	92.9	92.2	0.86	98.8	2.5	1.3	2.8	8.5	75	160.00	0.13750
T3C 180M-4	18.5	33.5	1460	92.6	93.6	93.0	0.86	121.0	2.5	1.8	3.0	9	76	169.40	0.15530
T3C 180L-4	22	39.2	1460	93	93.7	92.9	0.87	143.9	2.5	1.8	3.0	10	76	196.00	0.19433

# T3C Series IE3 Efficiency Motors Technical Data (400V/50Hz)

Model	Output (kW)	Rated current (A)	Rotation speed (r/min)	Efficiency 100% load (%)	Efficiency 75% load (%)	Efficiency 50% load (%)	Power factor (Φ)	Rated torque (N.m)	T <sub>st</sub> /T <sub>n</sub> (Times)	T <sub>min</sub> /T <sub>n</sub> (Times)	T <sub>max</sub> /T <sub>n</sub> (Times)	I <sub>st</sub> /I <sub>n</sub> (Times)	Nosie (dB)	Net weight (kg)	Moment of inertia (kg·m <sup>2</sup> )
T3C 200L-4	30	57.1	1470	93.6	93.7	93.2	0.81	194.9	2.5	1.8	2.8	9	79	252.00	0.29441
T3C 225S-4	37	65.4	1470	93.9	95.2	94.3	0.87	240.4	2.5	1.4	2.5	9.2	81	324.50	0.57838
T3C 225M-4	45	79.3	1470	94.2	95.2	94.5	0.87	292.3	2.5	1.5	2.5	9	81	352.90	0.65309
T3C 250M-4	55	95.4	1470	94.6	95.2	94.5	0.88	357.3	2.5	1.8	2.5	8.5	83	427.40	0.76504
T3C 280S-4	75	131.0	1480	95	95.1	94.8	0.87	484.0	2.5	1.8	2.8	10	86	673.30	1.99603
T3C 280M-4	90	160.5	1480	95.2	95.1	95.0	0.85	580.7	2.5	1.8	2.8	10	86	692.00	2.18345
T3C 315S-4	110	189.1	1480	95.4	95.7	94.6	0.88	709.8	2.2	1.5	2.6	9	93	1027.00	3.71808
T3C 315M-4	132	226.5	1480	95.6	95.8	95.0	0.88	851.8	2.2	1.5	2.6	9	93	1155.00	4.29667
T3C 315L1-4	160	273.9	1480	95.8	96.0	95.1	0.88	1032.4	2.2	1.5	2.6	9	97	1240.00	5.10990
T3C 315L2-4	200	337.9	1480	96	96.2	95.3	0.89	1290.5	2.2	1.5	2.6	9	97	1400.00	6.17334
T3C 355M1-4	220	371.7	1480	96	96.2	95.3	0.89	1419.6	2.0	1.3	2.3	8	101	1560.00	7.04227
T3C 355M2-4	250	422.3	1480	96	96.3	95.4	0.89	1613.2	2.0	1.3	2.3	8	101	1600.00	7.63820
T3C 355L1-4	280	473.0	1480	96	96.4	95.4	0.89	1806.8	2.0	1.3	2.3	8	101	1650.00	8.31927
T3C 355L2-4	315	532.1	1480	96	96.3	95.5	0.89	2032.6	2.0	1.3	2.3	8	101	1700.00	9.34080
T3C 90S-6	0.75	2.05	935	78.9	79.6	77.2	0.67	7.66	2.0	1.8	2.2	5	57	21.50	0.00435
T3C 90L-6	1.1	2.97	940	81	81.5	80.2	0.66	11.18	2.3	1.8	2.2	5.2	57	25.50	0.00611
T3C 100L-6	1.5	3.55	940	82.5	83.0	81.6	0.74	15.24	2.0	1.7	2.2	5.2	61	33.50	0.00972
T3C 112M-6	2.2	5.38	940	84.3	85.0	83.2	0.70	22.35	2.0	1.8	2.2	6.2	65	40.00	0.01637
T3C 132S-6	3	6.84	940	85.6	86.1	84.5	0.74	30.48	2.0	1.7	2.2	6	69	59.00	0.03223
T3C 132M1-6	4	8.99	950	86.8	87.6	85.2	0.74	40.21	2.0	1.6	2.5	7	69	75.50	0.04338
T3C 132M2-6	5.5	12.71	950	88	88.8	86.9	0.71	55.29	2.3	1.8	2.5	7.5	69	76.30	0.05443
T3C 160M-6	7.5	16.2	960	89.1	90.3	88.0	0.75	74.6	2.3	1.4	2.8	7.5	73	112.00	0.08726
T3C 160L-6	11	23.1	960	90.3	91.2	88.5	0.76	109.4	2.5	1.4	2.8	8.5	73	134.00	0.13544
T3C 180L-6	15	30.1	960	91.2	92.0	90.3	0.79	149.2	2.5	1.4	2.8	8	73	184.50	0.27973
T3C 200L1-6	18.5	36.4	970	91.7	92.3	90.6	0.80	182.1	2.5	1.4	2.8	9.5	76	231.00	0.38345
T3C 200L2-6	22	42.5	970	92.2	93.0	91.3	0.81	216.6	2.5	1.5	2.8	10	76	249.00	0.44941
T3C 225M-6	30	53.0	975	92.9	93.8	90.9	0.88	293.8	1.8	1.5	2.2	7	76	339.00	0.67058
T3C 250M-6	37	67.3	975	93.3	94.0	91.8	0.85	362.4	1.8	1.3	2.0	7	78	399.40	0.99243
T3C 280S-6	45	83.5	980	93.7	94.6	92.7	0.83	438.5	2.5	1.8	2.8	10	80	551.00	2.20274
T3C 280M1-6	55	99.3	980	94.1	95.0	93.4	0.85	536.0	2.5	1.8	2.8	10	80	624.30	2.57302
T3C 315S-6	75	139.6	980	94.6	94.8	93.2	0.82	730.9	2.0	1.3	2.3	7.5	85	860.00	3.80317
T3C 315M-6	90	166.9	980	94.9	95	93.4	0.82	877.0	2.0	1.3	2.3	7.5	85	970.00	4.45274
T3C 315L1-6	110	203.6	980	95.1	95.4	94	0.82	1071.9	2.0	1.3	2.3	7.5	85	1070.00	5.53956
T3C 315L2-6	132	243.6	980	95.4	95.7	94.2	0.82	1286.3	2.0	1.3	2.3	7.5	85	1196.00	6.62638
T3C 355M1-6	160	294.6	980	95.6	95.8	94.3	0.82	1559.2	2.0	1.3	2.3	7.5	92	1537.00	8.97637
T3C 355M2-6	200	367.5	980	95.8	95.8	94.3	0.82	1949.0	2.0	1.3	2.3	7.5	92	1720.00	11.00175
T3C 355L1-6	220	404.2	980	95.8	96	94.2	0.82	2143.9	2.0	1.3	2.3	7.5	92	1800.00	11.64134
T3C 355L-6	250	459.3	980	95.8	96	94.3	0.82	2436.2	2.0	1.3	2.3	7.5	92	1880.00	13.56011

# T4C Series IE4 Efficiency Motors Technical Data (400V/50Hz)

Model	Output (kW)	Rated current (A)	Rotation speed (r/min)	Efficiency 100% load (%)	Efficiency 75% load (%)	Efficiency 50% load (%)	Power factor (Φ)	Rated torque (N.m)	$T_d/T_n$ (Times)	$T_{max}/T_n$ (Times)	$T_{max}/T_n$ (Times)	$I_w/I_n$ (Times)	Nosie (dB)	Net weight (kg)	Moment of inertia (kg·m <sup>2</sup> )
T4C 801-2	0.75	1.56	2920	83.5	83.7	82	0.83	2.45	2.2	1.5	2.3	8.5	62	16	0.00138
T4C 802-2	1.1	2.25	2920	85.2	85.4	84.5	0.83	3.6	2.2	1.5	2.3	8.5	62	17	0.00179
T4C 90S-2	1.5	2.94	2940	86.5	86.7	86.4	0.85	4.87	2.2	1.5	2.3	9	67	23	0.00264
T4C 90L-2	2.2	4.20	2940	88	88.3	87.8	0.86	7.15	2.2	1.4	2.3	9	67	26	0.00358
T4C 100L-2	3	5.59	2945	89.1	89.3	88.9	0.87	9.73	2.2	1.4	2.3	9.5	74	36	0.00576
T4C 112M-2	4	7.29	2945	90	90.2	89.8	0.88	13	2.2	1.4	2.3	9.5	77	50	0.00973
T4C 132S1-2	5.5	9.92	2950	90.9	91.2	90.7	0.88	17.8	2	1.2	2.3	9.5	79	67	0.0284
T4C 132S2-2	7.5	13.26	2950	91.7	92	91.5	0.89	24.3	2	1.2	2.3	9.5	79	72	0.0349
T4C 160M1-2	11	19.27	2960	92.6	92.8	92.5	0.89	35.5	2	1.2	2.3	9.5	81	129	0.0695
T4C 160M2-2	15	26.07	2960	93.3	93.5	93.1	0.89	48.42	2	1.2	2.3	9.5	81	155	0.0848
T4C 160L-2	18.5	32.02	2965	93.7	93.9	93.6	0.89	59.6	2	1.1	2.3	9.5	81	176	0.102
T4C 180M-2	22	37.96	2965	94	94.2	93.8	0.89	70.9	2	1.1	2.3	9.5	83	220	0.163
T4C 200L1-2	30	51.48	2970	94.5	94.7	94.3	0.89	96.5	2	1.1	2.3	9	84	278	0.267
T4C 200L2-2	37	63.30	2970	94.8	95	94.7	0.89	119	2	1.1	2.3	9	84	292	0.303
T4C 225M-2	45	76.82	2975	95	95.2	94	0.89	144.5	2	1	2.3	9	86	387	0.393
T4C 250M-2	55	93.60	2980	95.3	95.5	94.3	0.89	176.3	2	1	2.3	9	89	531	1.044
T4C 280S-2	75	127.23	2980	95.6	95.8	95	0.89	240.46	1.8	0.9	2.3	8.5	91	625	1.267
T4C 280M-2	90	152.36	2980	95.8	95.9	95.2	0.89	288.55	1.8	0.9	2.3	8.5	91	700	1.495
T4C 315S-2	110	185.83	2980	96	96.1	95.6	0.89	352.67	1.8	0.9	2.3	8.5	92	1110	2.036
T4C 315M-2	132	222.53	2980	96.2	96.2	95.7	0.89	423.2	1.8	0.9	2.3	8.5	92	1228	2.352
T4C 315L1-2	160	269.45	2980	96.3	96.3	95.8	0.89	513	1.8	0.9	2.2	8.5	92	1321	2.720
T4C 315L2-2	200	336.12	2980	96.5	96.5	96	0.89	641.2	1.8	0.8	2.2	8.5	92	1450	3.273
T4C 355M-2	250	420.15	2980	96.5	96.5	96	0.89	801.5	1.6	0.8	2.2	8.5	97	1700	4.481
T4C 355L-2	315	529.39	2980	96.5	96.5	96	0.89	1009.9	1.6	0.8	2.2	8.5	97	2030	5.604
T4C 802-4	0.75	1.71	1435	85.7	85.9	83.9	0.74	4.99	2.3	1.6	2.3	8.5	56	19	0.00301
T4C 90S-4	1.1	2.43	1445	87.2	87.4	85.7	0.75	7.27	2.3	1.6	2.3	8.5	59	25	0.00487
T4C 90L-4	1.5	3.23	1445	88.2	88.4	87.1	0.76	9.92	2.3	1.6	2.3	9	59	31	0.00646
T4C 100L1-4	2.2	4.49	1450	89.5	89.7	88.4	0.79	14.5	2.3	1.5	2.3	9	64	39	0.0132
T4C 100L2-4	3	5.99	1450	90.4	90.6	90	0.8	19.77	2.3	1.5	2.3	9.5	64	45	0.0183
T4C 112M-4	4	7.92	1465	91.1	91.3	90.9	0.8	26.1	2.3	1.5	2.3	9.5	65	61	0.0236
T4C 132S-4	5.5	10.80	1470	91.9	92.1	91.5	0.8	35.75	2	1.4	2.3	9.5	71	75	0.0627
T4C 132M-4	7.5	14.43	1470	92.6	92.8	92	0.81	48.75	2	1.4	2.3	9.5	71	83	0.0716
T4C 160M-4	11	20.50	1475	93.3	93.5	92.8	0.83	71.25	2	1.4	2.3	9.5	73	160	0.144
T4C 160L-4	15	27.45	1475	93.9	94.1	92.8	0.84	97.16	2	1.4	2.3	9.5	73	179	0.184
T4C 180M-4	18.5	33.35	1475	94.2	94.4	93.6	0.85	119.83	2	1.2	2.3	9.5	76	218	0.266
T4C 180L-4	22	39.53	1475	94.5	94.7	93.8	0.85	142.5	2	1.2	2.3	9.5	76	249	0.303
T4C 200L-4	30	53.68	1480	94.9	95.2	94	0.85	193.67	2	1.2	2.3	9	76	295	0.566
T4C 225S-4	37	66.00	1480	95.2	95.4	94.6	0.85	238.85	2	1.2	2.3	9	78	403	0.794
T4C 225M-4	45	80.10	1480	95.4	95.6	95	0.85	290.5	2	1.1	2.3	9	78	425	0.869
T4C 250M-4	55	96.46	1480	95.7	95.9	95.3	0.86	355	2	1.1	2.3	9	79	550	1.435
T4C 280S-4	75	129.61	1485	96	96.1	95.4	0.87	482.5	2	1	2.3	8.5	80	644	2.149
T4C 280M-4	90	153.61	1485	96.1	96.1	95.8	0.88	579	2	1	2.3	8.5	80	714	2.377
T4C 315S-4	110	185.25	1485	96.3	96.3	95.9	0.89	707.7	1.8	1	2.2	8.5	88	1130	3.943
T4C 315M-4	132	222.07	1485	96.4	96.4	96.2	0.89	849.3	1.8	1	2.2	8.5	88	1260	4.471
T4C 315L1-4	160	265.63	1485	96.6	96.6	96.3	0.9	1029.4	1.8	1	2.2	8.5	88	1377	5.267
T4C 315L2-4	200	331.70	1485	96.7	96.7	96.3	0.9	1286.8	1.8	0.9	2.2	8.5	88	1558	6.291
T4C 355M-4	250	414.62	1485	96.7	96.7	96.3	0.9	1608.4	1.8	0.9	2.2	8.5	92	1740	10.212
T4C 355L-4	315	522.42	1485	96.7	96.7	96.4	0.9	2026.6	1.8	0.8	2.2	8.5	92	1933	11.374



# T4C Series IE4 Efficiency Motors Technical Data (400V/50Hz)

Model	Output (kW)	Rated current (A)	Rotation speed (r/min)	Efficiency 100% load (%)	Efficiency 75% load (%)	Efficiency 50% load (%)	Power factor (Φ)	Rated torque (N.m)	$T_{st}/T_n$ (Times)	$T_{max}/T_n$ (Times)	$T_{max}/T_n$ (Times)	$I_{sc}/I_n$ (Times)	Nosie (dB)	Net weight (kg)	Moment of inertia (kg·m <sup>2</sup> )
T4C 90S-6	0.75	1.87	940	82.7	82.9	83	0.7	7.62	2.1	1.5	2.1	7.5	57	30	0.00611
T4C 90L-6	1.1	2.68	940	84.5	84.8	84.4	0.7	11.18	2.1	1.3	2.1	7.5	57	34	0.00884
T4C 100L-6	1.5	3.55	950	85.9	86.3	85.8	0.71	15.1	2.1	1.3	2.1	7.5	61	39	0.0170
T4C 112M-6	2.2	5.12	950	87.4	87.8	87.2	0.71	22.1	2	1.3	2.1	7.5	65	45	0.0304
T4C 132S-6	3	6.88	970	88.6	88.9	88.6	0.71	29.6	2	1.3	2.1	7.5	69	65	0.0492
T4C 132M1-6	4	8.96	970	89.5	89.8	89.4	0.72	39.4	2	1.3	2.1	8	69	67	0.0606
T4C 132M2-6	5.5	12.18	970	90.5	90.7	90.4	0.72	54.2	2	1.3	2.1	8	69	72	0.0860
T4C 160M-6	7.5	15.60	970	91.3	91.5	91.2	0.76	73.9	2	1.3	2.1	8	73	145	0.149
T4C 160L-6	11	22.34	975	92.3	92.5	92.2	0.77	107.8	2	1.2	2.1	8.5	73	185	0.220
T4C 180L-6	15	29.13	975	92.9	93.2	92.8	0.8	147	2	1.2	2.1	8.5	73	226	0.363
T4C 200L1-6	18.5	35.74	975	93.4	93.6	93.3	0.8	181.3	2	1.2	2.1	8.5	73	246	0.467
T4C 200L2-6	22	41.84	975	93.7	93.9	93.6	0.81	215.6	2	1.2	2.1	8.5	73	271	0.568
T4C 225M-6	30	56.06	980	94.2	94.4	94	0.82	292.5	2	1.2	2.1	8.3	74	351	0.938
T4C 250M-6	37	68.09	980	94.5	94.7	94.3	0.83	360.7	2	1.2	2.1	8.3	76	430	1.633
T4C 280S-6	45	82.55	985	94.8	95	94.7	0.83	436.5	2	1.1	2	8.5	78	533	2.336
T4C 280M1-6	55	99.38	985	95.1	95.3	95	0.84	533.5	2	1.1	2	8.5	78	610	2.703
T4C 315S-6	75	135.09	990	95.4	95.6	95.3	0.84	723.8	1.6	1	2	8	83	1020	4.414
T4C 315M-6	90	159.86	990	95.6	95.8	95.4	0.85	868.6	1.6	1	2	8	83	1212	5.257
T4C 315L1-6	110	194.98	990	95.8	96	95.6	0.85	1061.6	1.6	1	2	8	83	1277	6.309
T4C 315L2-6	132	230.77	990	96	96.2	95.9	0.86	1273.9	1.6	1	2	8	83	1400	7.511
T4C 355M1-6	160	279.14	990	96.2	96.3	96	0.86	1544.1	1.6	1	2	8	85	1740	12.140
T4C 355M2-6	200	348.57	990	96.3	96.3	96.1	0.86	1930.1	1.6	0.9	2	8	85	1893	15.037
T4C 355L-6	250	434.80	990	96.5	96.5	96.4	0.86	2412.7	1.6	0.9	2	8	85	2008	16.968
T4C 100L1-8	0.75	2.09	700	78.4	78.6	79	0.66	10.24	2	1.3	2	7	59	29	0.00996
T4C 100L2-8	1.1	2.93	700	80.8	81	80.6	0.67	15	2	1.2	2	7	59	34	0.0151
T4C 112M1-8	1.5	3.80	710	82.6	82.8	82.4	0.69	20.2	2	1.2	2	7	61	39	0.0223
T4C 132S-8	2.2	5.37	715	84.5	84.7	84.3	0.7	29.4	1.8	1.2	2	7.5	64	56	0.0492
T4C 132M-8	3	7.20	715	85.9	86.2	85.6	0.7	40.1	1.8	1.2	2	7.8	64	64	0.0634
T4C 160M1-8	4	9.34	725	87.1	87.3	86.9	0.71	52.7	1.8	1.2	2	7.9	68	117	0.0910
T4C 160M2-8	5.5	12.49	730	88.3	88.5	88.2	0.72	72	1.8	1.2	2	8.1	68	138	0.118
T4C 160L-8	7.5	16.38	730	89.3	89.5	89	0.74	98.2	1.8	1.2	2	7.8	68	161	0.171
T4C 180L-8	11	23.73	735	90.4	90.6	90	0.74	143	1.8	1.1	2	7.9	70	188	0.289
T4C 200L-8	15	31.65	735	91.2	91.4	91	0.75	195	1.8	1.1	2	8	73	220	0.417
T4C 225S-8	18.5	38.83	735	91.7	91.9	91.4	0.75	240.5	1.8	1.1	2	8.1	73	294	0.698
T4C 225M-8	22	45.37	740	92.1	92.3	92	0.76	284	1.8	1.1	2	8.3	73	319	0.829
T4C 250M-8	30	60.66	740	92.7	92.9	92.6	0.77	387.3	1.8	1.1	2	7.9	75	383	1.393
T4C 280S-8	37	73.54	740	93.1	93.3	93	0.78	477.7	1.8	1.1	2	7.9	76	516	2.155
T4C 280M1-8	45	89.16	740	93.4	93.6	93.3	0.78	581	1.8	1	2	7.9	76	575	2.643
T4C 315S-8	55	105.90	740	93.7	93.9	93.4	0.8	710	1.6	1	2	8.2	82	900	4.179
T4C 315M-8	75	143.65	740	94.2	94.5	94	0.8	968.3	1.6	0.9	2	7.6	82	1068	5.604
T4C 315L1-8	90	169.89	740	94.4	94.6	94.2	0.81	1162	1.6	0.9	2	7.7	82	1158	6.659
T4C 315L2-8	110	206.98	745	94.7	94.9	94.5	0.81	1410.7	1.6	0.9	2	7.7	82	1316	8.331
T4C 355M1-8	132	247.86	745	94.9	95.2	94.8	0.81	1693	1.6	0.9	2	7.7	89	1616	13.896
T4C 355M2-8	160	296.15	745	95.1	95.3	95	0.82	2052	1.6	0.9	2	7.7	89	1794	16.860
T4C 355L-8	200	369.02	745	95.4	95.5	95.2	0.82	2565	1.6	0.9	2	7.8	89	1944	19.825