

QUICK SELECTION / Selezione veloce										input speed (n ₁) = 1400 min ⁻¹							
Output Speed n ₂ [min ⁻¹]	Ratio i	Motor power P _{1M} [kW]	Output torque M _{2M} [Nm]	Service factor f.s.	Nominal power P _{1R} [kW]	Nominal torque M _{2R} [Nm]	Available B5 motor flanges				Available B14 motor flanges			Dynamic efficiency RD	Tooth Module Mn [mm]	Ratios code	
							C	D	E	F	R	T	U				
							71	80	90	100 112	80	90	100 112				
200	7	4.0	168	1.5	6.1	257		B	B			B	B		88	4.23	01
140	10	4.0	218	1.3	5.2	284		B	B			B	B		80	4.2	02
100	14	3.0	223	1.4	4.1	305		B	B			B	B		78	4.5	03
70	20	2.2	237	1.2	2.7	294		B	B			B	B		79	3.4	04
64	22	2.2	258	1.1	2.5	294		B	B			B	B		78	3.1	05
50	28	2.2	315	1.1	2.4	347		B	B	B		B	B		75	4.7	06
37	38	1.5	276	1.2	1.8	336	B	B	B			B	B		71	3.5	07
30	46	1.5	320	1.0	1.5	326	B	B				B	B		68	3.1	08
27	52	1.1	258	1.1	1.2	289	B	B				B	B		66	2.7	09
21	67	1.1	327	0.9	0.97	289	B	B				B	B		65	2.1	10
18.9	74	0.75	220	1.2	0.91	268	B	B				B	B		58	1.9	11
14.6	96	0.55	191	1.3	0.70	242	B	B				B	B		53	1.5	12

Motor Flanges Available Flange Motore Disponibili
 B Supplied with Reduction Bushing Fornito con Bussola di Riduzione
 B Available on Request without reduction bushing Disponibile a Richiesta senza Bussola di Riduzione
 C Motor Flange Holes Position Posizione Fori Flangia Motore

EN Unit 085 is supplied with synthetic oil, providing "long life" lubrication. For mounting position V5-V6 please contact us. See table 1 for lubrication and recommended quantity. In table 2 please see possible radial loads and axial loads on the gearbox. For complete documentation please visit our web site.

I Il riduttore tipo 085 viene fornito lubrificato a vita con olio sintetico. Per posizioni V5-V6 contattare il ns. servizio tecnico. Vedi tab.1 per oli e quantità consigliati. In tab.2 sono presenti i carichi radiali e assiali applicabili al riduttore. Per la documentazione completa consulta il nostro sito.

D Für die Lebensdauerschmierung ist das Getriebe der Größe 085 mit synthetischem Öl befüllt. Bei Einbaulage V5 oder V6 bitten wir um Rücksprache. In Tabelle 1 ist die Schmiermenge und das empfohlene Schmiermittel angegeben. In Tabelle 2 sind die zulässigen Radial- und Axialbelastungen des Getriebes aufgeführt. Die komplette Dokumentation, Wartungs- und Inbetriebnahmeanleitungen finden Sie unter.

E El reductor tamaño 085 se suministra, lubricado de por vida con aceite sintético. Para las posiciones V5 y V6 contactar con nuestro servicio técnico. Ver tabla 1, para cantidades y aceites recomendados. En la tabla 2, se encuentran las cargas radiales y axiales admitidas por el reductor. Para documentación completa, consultar nuestra Web.

LUBRICATION 085 Oil Quantity 1.20 Lt.

AGIP Telium VSF 320	SHELL Omala S4 WE 320
----------------------------	------------------------------

For all details on lubrication and plugs check our website **tab. 1**
Per maggiori dettagli su lubrificazione e tappi olio vedi il nostro sito web

RADIAL AND AXIAL LOADS

Output shaft Albero di uscita

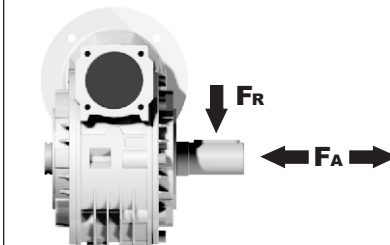

n ₂ [min ⁻¹]	FA [N]	FR [N]
200	500	2500
150	580	2900
100	600	3000
75	700	3500
50	800	4000
25	1000	5000
15	1160	5800

Input shaft albero in entrata

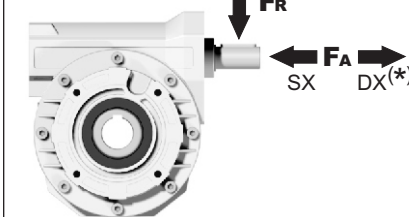

n ₁ [min ⁻¹]	FA [N]	FR [N]
1400	160	809

***Strong axial loads in the DX direction are not allowed.**
Non sono consentiti forti carichi assiali con direzione DX

tab. 2

SELECT THIS TYPE AND THIS SPECIFIC SIZE ON THE WEB PAGES TO GET COMPLETE TECHNICAL DATA.
Selezionare tipo e gandezza specifica nel sito web per la documentazione completa.

P085FB... Basic wormbox
Riduttore base

Gearbox weight
peso riduttore **11.00 kg**

M. flanges	Kit code	øF	A
71B5	K023.4.041	160	116
80/90B5	K023.4.042	200	118
100/112B5	K023.4.043	250	124
80B14	K085.4.046	120	116
90B14	K085.4.045	140	116
100/112B14	K023.4.041	160	116

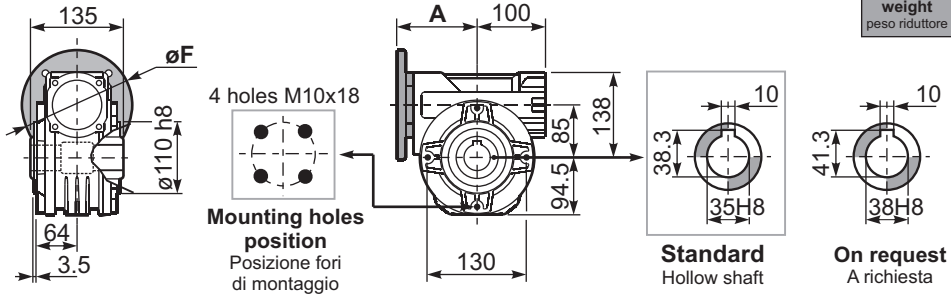

P085PA... Feet
Piedini

P085PB... Feet
Piedini

P085PV... Feet
Piedini

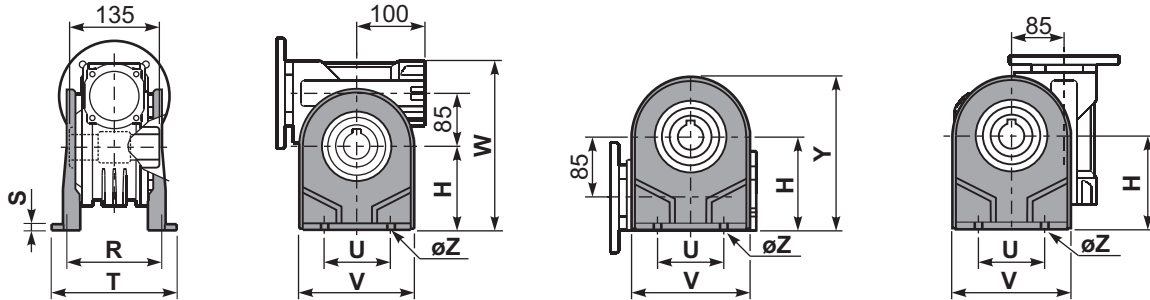

	H	R	S	T	U	V	Y	W	øZ	kit code
type B	142	145	5	182	140	180	236.5	280	ø10.5	K085.9.022
type S	-	-	-	-	-	-	-	-	-	-

P085FC... Output flange
Flangia uscita

P085BR... Reaction arm
Braccio di reazione

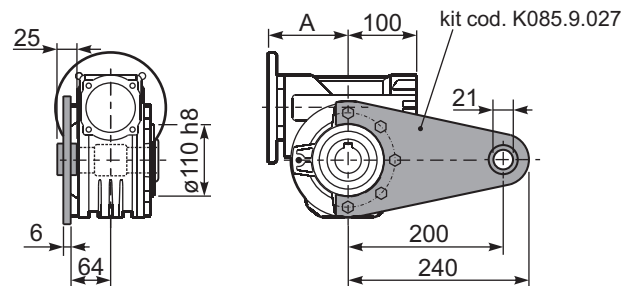
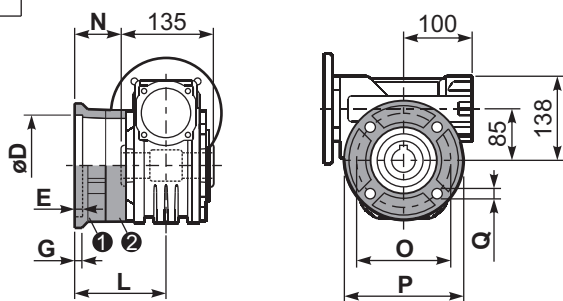

type B	øD	E	G	L	N	O	P	Q	kit code
FC	152 ^{+0.06} / _{+0.00}	5	16	108	40.5	176	205	13	① K085.9.010 ② -
FL	152 ^{+0.06} / _{+0.00}	5	16	148.5	81	176	205	13	① K085.9.010 ② K085.0.201
type S	øD	E	G	L	N	O	P	Q	kit code
F1	130 H7	5	13	117.5	50	165	200	11.5	① KS085.9.012 ② -
F2	152 ^{+0.06} / _{+0.00}	5	15	147.5	80	180	205	12.5	① KS085.9.013 ② -
F4	130 H7	5	13	106.5	39	165	200	13	① KS085.9.015 ② -

P085.....S... Single Shaft
Albero lento semplice

P085.....D... Double Shaft
Albero lento bisp.

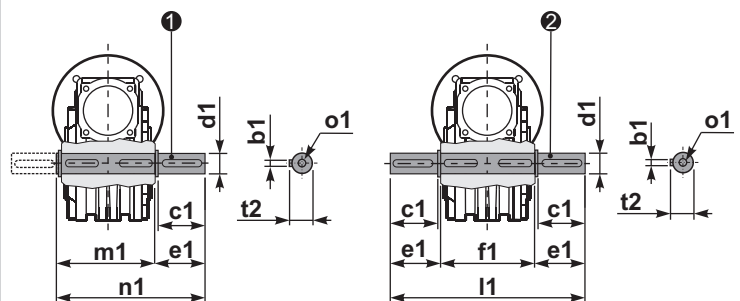

R085FB... Input shaft
Albero in entrata

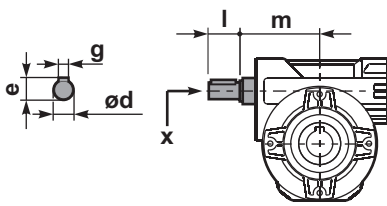

	ød	e	g	l	m	x	kit code
type B	25 h6	28	8	50	112	M8x20	① K085.5.007 PAM90 ② K085.5.008 PAM100
type S	24 h6	27	8	50	112	M8x20	① KS085.5.009 PAM90 ② KS085.5.011 PAM100

	b1	c1	d1	e1	f1	l1	m1	n1	t2	o1
type B	10	60	35 ^{-0.005} / _{-0.020}	73.5	135	282	141	214.5	38	M10x23
type S	-	-	-	-	-	-	-	-	-	-