

103-H7823-1740

SANYO DENKI
SANMOTION

Dimensions (Unit:mm)

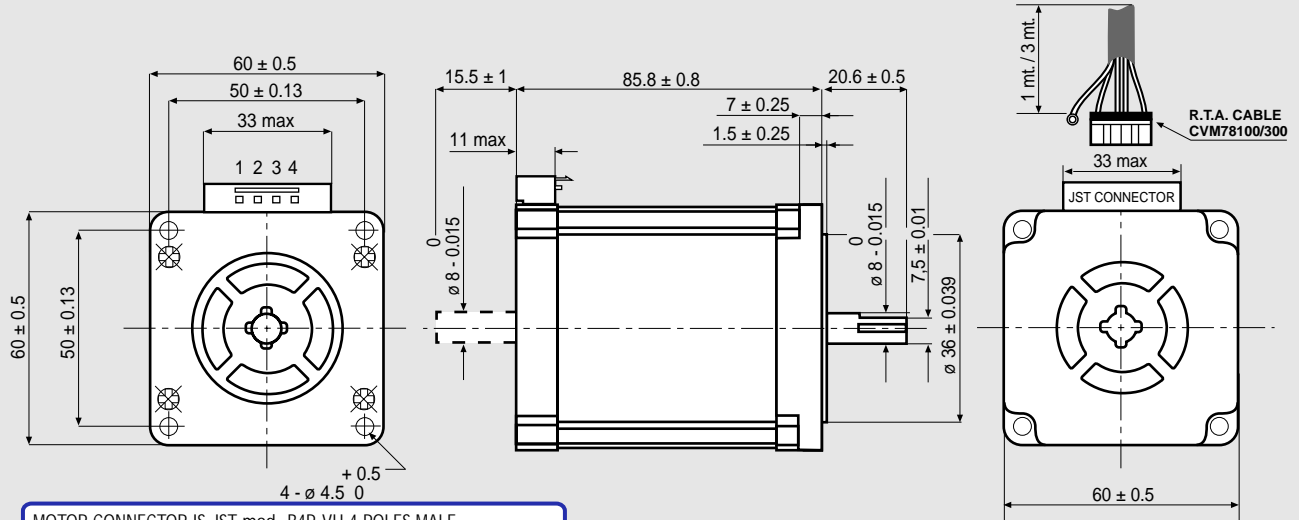

MOTOR CONNECTOR IS JST mod. B4P-VH 4 POLES MALE.
FOR CONNECTION USE JST mod. VHR-4N FEMALE CONNECTOR AND
mod. SVH-21 T-P1.1 CONTACTS.
NOTE: 103-H7823-1740 MOTORS NEED CVM78100 AND CVM78300
R.T.A. CABLES. CONTACT R.T.A. FOR FURTHER DETAILS.

FEATURES

MODEL	103-H7823-1740 (103-H7823-1714)
BASIC STEP ANGLE	1.8° ± 0.09°
BIPOLAR CURRENT (Amp)	4.0
UNIPOLAR CURRENT (Amp)	
RESISTANCE (Ohm)	0.65
INDUCTANCE (mH)	2.4
BIPOLAR HOLDING TORQUE (Ncm)	300
UNIPOLAR HOLDING TORQUE (Ncm)	
ROTOR INERTIA (Kgm ² × 10 ⁻⁷)	840
THEORETICAL ACCELERATION (rad × sec. ⁻²)	35700
BACK E.M.F. (V/Krpm)	75
MASS (Kg)	1.4
LEADS CODE	V

Codes between brackets refer to double shaft models.
Le sigle fra parentesi si riferiscono ai modelli bialbero.

TORQUE/SPEED CURVE

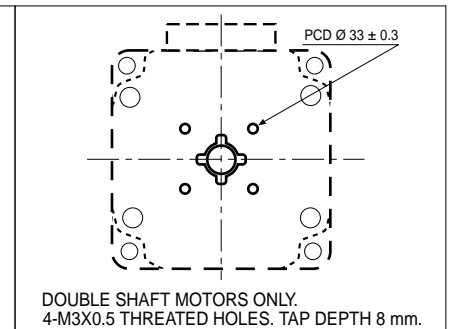
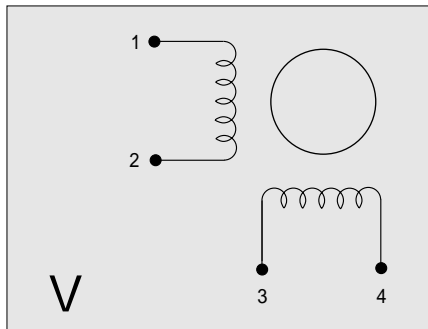
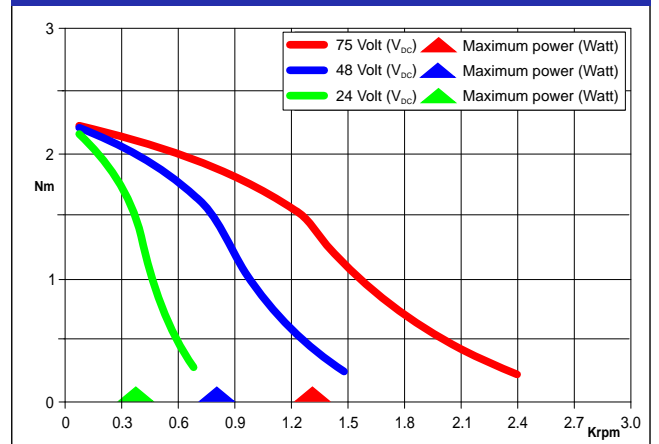

Suggested R.T.A. driver: CSD/CSD J/A-CSD Series, NDC/A-NDC Series, ADW Series, HGD Series, PLUS Series.