

ADVANCED MICROPROCESSOR BASED PERMANENT MAGNET MOTOR SPEED CONTROLLERS

MODELS 1227/1237



DESCRIPTION

Curtis PMC Models 1227/1237 are advanced, programmable micro-processor based motor speed controllers which offer smooth, silent, cost-effective control of motor speed and torque. Four quadrant, full bridge power output stages provide for solid state motor reversing and full regenerative braking power. Model 1227 provides extensive standard features (•). Model 1237 provides additional features (••) for special industrial applications.

WARRANTY

One year from date of delivery.

CURTIS

Application

Curtis PMC Models 1227/1237 are designed for large permanent magnet motors, such as those used by large mobility aids, scrubbers, personnel carriers, small golf cars, small walkies etc.

Features

- Full bridge power MOSFET design provides infinitely variable forward, reverse, drive and brake control; silent high frequency and high efficiency operation.
- Programmable through the Curtis PMC 1307 handheld programmer, an optional universal unit used for programming, testing and diagnostics.
- Complete diagnostics also available through the status LED.
- Fully compliant with all applicable international standards and TÜV requirements.
- Available for wig-wag (center off) and single ended (speed pot and direction switch) throttles for both standard full stroke and restricted range 5k Ω potentiometers. Also accepts 0-5v throttle signals.
- Throttle calibration mode aids the mechanical centering of the throttle using the 1307 Programmer to enter the mode. The horn will sound and the status LED will be off whenever the throttle is outside the neutral band.
- MultiMode™ input selects between two different operating modes. MultiMode™ allows changes in speed, accel, decel, current limit, and IR compensation. This allows optimization of vehicle characteristics in each mode, for example indoor/outdoor.
- Speed limit input provides additional variable speed limiting, in both mode ranges, with an external pot.
- Linear acceleration and deceleration with softened response for smooth operation.
- Current limited in both driving and regenerative braking.
- Load compensation stabilizes speed on ramps and over obstacles. Compensates for battery voltage, voltage drops, and motor resistance.



Features continued

- High pedal disable (HPD) function monitors status of the throttle during turn on and prevents operation until the throttle has been returned to neutral.
- Power off decel provides a controlled deceleration if the key switch is turned off while driving.
- Comprehensive fault detect function monitors main contactor, output stage, throttle demand vs. output, etc.
- Throttle fault circuitry shuts off controller if throttle signal goes out of range for any reason.
- Missing brake detector forces neutral in the event of an open brake circuit (programmable).
- Anti rollback/roll forward circuitry sets brake delay according to speed and direction for improved braking response and minimized rollback on hills, etc.
- Over-current protected brake driver protects the controller from shorts in the brake or its wiring. This low side output driver may also be programmed for side broom or brush contactor, hourmeter, BDI enable, etc.
- Brake PWM allows the brake driver to be programmed to a reduced holding voltage.
- Reverse output drives a piezo beeper (customer supplied) in reverse.
- "Push Too Fast" feature allows motor to coast with controller off and brake released. Pushing too fast automatically and safely shorts the motor to limit maximum coasting speed.
- Push input electrically releases brake for key-on pushing (requires that the vehicle be stopped first).
- Inhibit input disables the controller and puts the vehicle in a safe state during charging, etc.
- Power saver deactivates the main relay after 25 seconds and entire controller after 25 minutes of non-operation.
- Under voltage cutback function protects against low battery voltage.
- Thermally protected and compensated for stable output and overtemperature protection.
- Reverse polarity protected (battery input).
- Momentary input option with integral LED drivers. Allows the use of membrane on-off, reverse, and mode switches.

Model 1237 Only

- SRO input sequencing options.
- Emergency reverse (belly button) input causes immediate reversal.
- Programmable high side driver output for brake light, belly button check, BDI enable, hourmeter, side broom contactor, etc.

Specifications

CURTIS PMC MODELS	NOMINAL BATTERY VOLTAGE (volts)	CURRENT LIMIT (amps)	1 MIN RATING (amps)	1 HOUR RATING (amps)	TYP. VOLTAGE DROP @ 20A (volts)	UNDER VOLTAGE CUTBACK (volts)	OVER VOLTAGE LIMIT (volts)
1227-21XX	24	150	150	80	0.20	16	36
1227-24XX	24	200	200	90	0.15	16	36
1227-31XX	36	120	120	65	0.20	26	48
1227-34XX	36	160	160	70	0.15	26	48
1227-41XX	48	100	100	55	0.40	35	64
1237-21XX	24	150	150	80	0.20	16	36
1237-24XX	24	200	200	90	0.15	16	36
1237-31XX	36	120	120	65	0.20	26	48
1237-34XX	36	160	160	70	0.15	26	48
1237-41XX	48	100	100	55	0.40	35	64

TÜV Compliance

This Curtis product complies with the regulations of TÜV, the German service company which tests products and sets standards for product safety and quality. EMC compliance depends upon the installation and is the responsibility of the equipment manufacturer. Shielding may or may not be needed. When installed with the recommended shielding, the controller itself will meet TÜV EMC requirements. The deceleration adjustment must be set to meet all applicable TÜV braking distance requirements.

Dimensions: mm (inches)

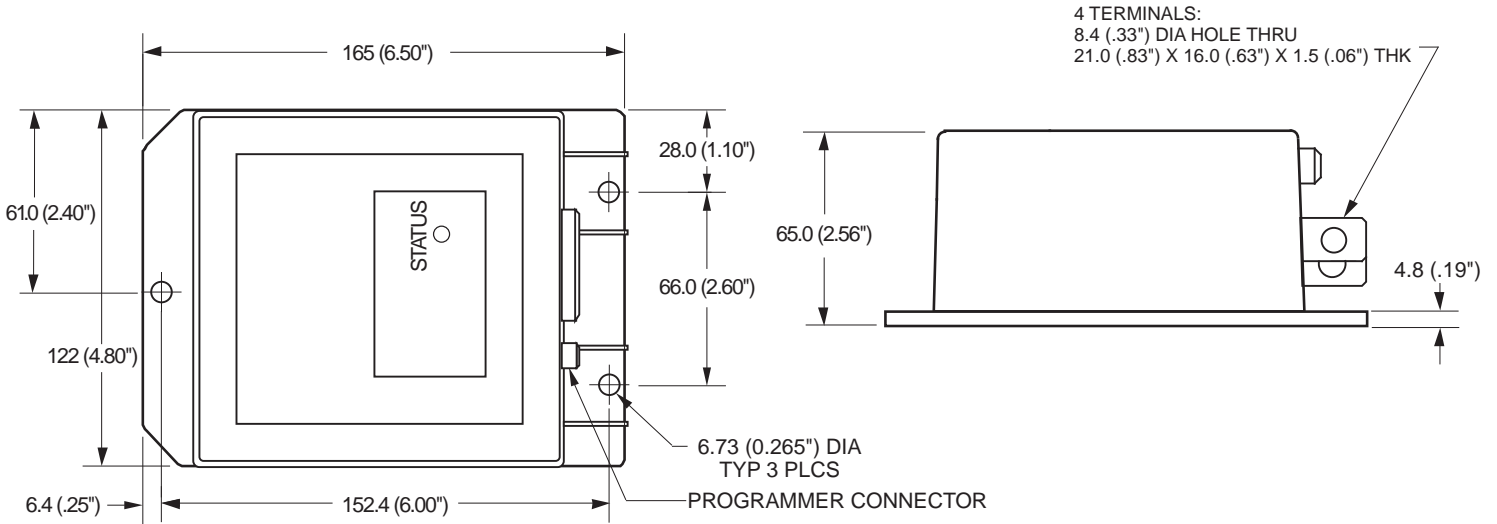

Typical Wiring Diagram

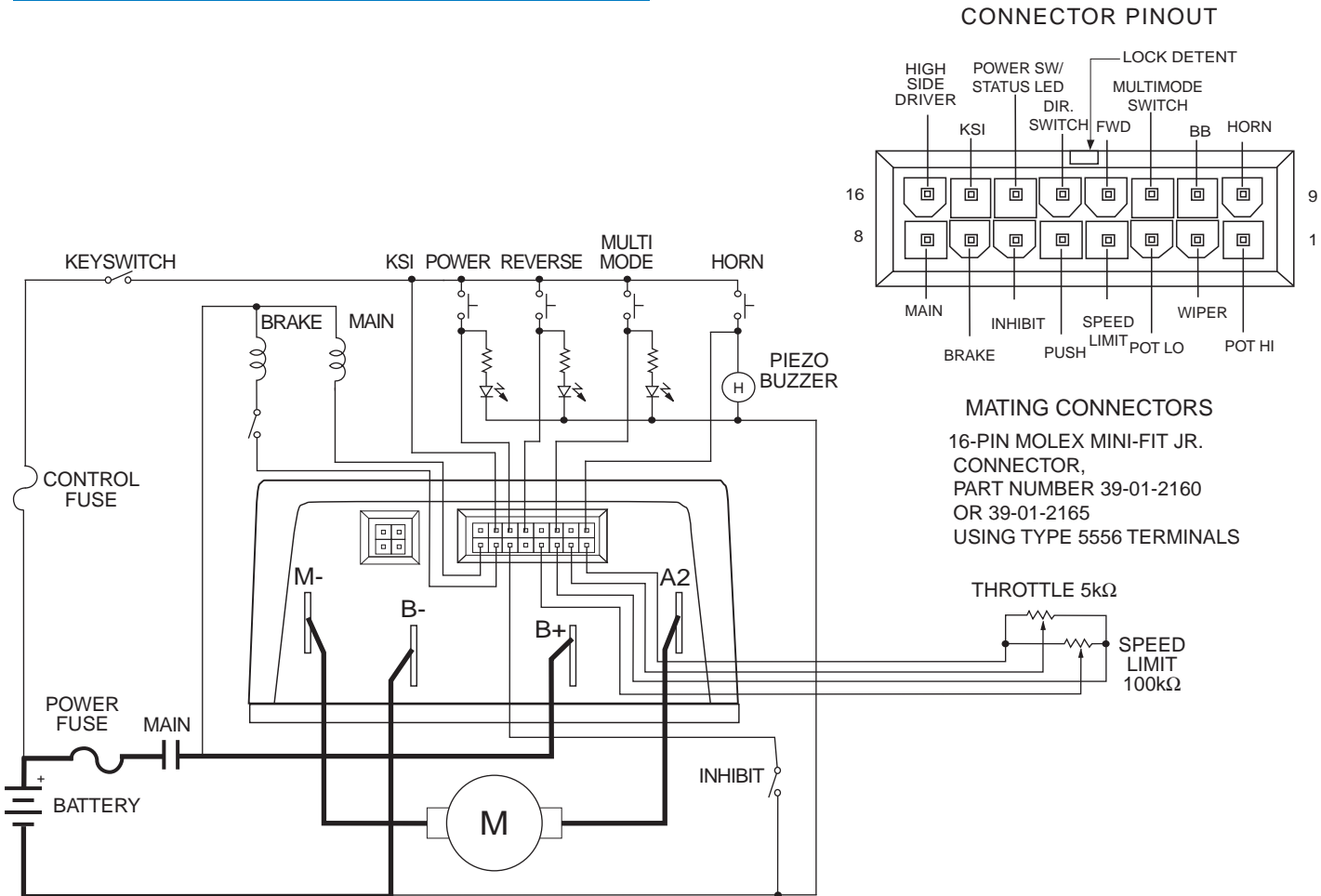

CONNECTOR PINOUT

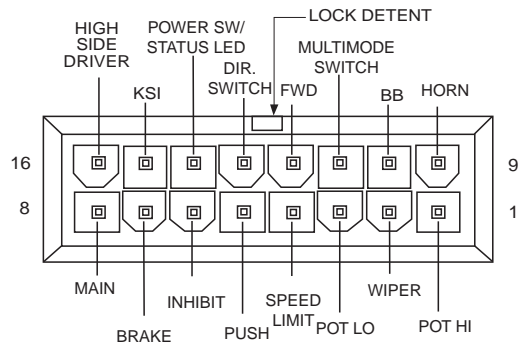

MATING CONNECTORS

16-PIN MOLEX MINI-FIT JR. CONNECTOR, PART NUMBER 39-01-2160 OR 39-01-2165 USING TYPE 5556 TERMINALS