



Servo gearboxes



SERVO gears



MECHANICAL gears



INDUSTRIAL gears

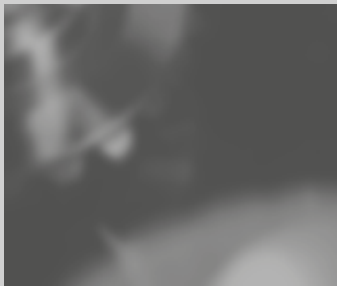

W E L C O M E T O V O G E L A N T R I E B S T E C H N I K

We thank you for your interest in our low backlash gearboxes. VOGEL Antriebstechnik has been highly regarded for more than 60 years offering a wide variety of products to a broad range of business sectors with applications that require innovative, dependable gearbox manufacturing technology. We develop high quality products that are very convincing with their precision, long service life and a high power density. We take advantage of a continuous dialogue with our customers and of constant communication with research and scientific sources.

Our primary focus is to supply you, our customer and partner, with the most cost-effective and efficient product solutions for your needs, in order to safeguard your viability in future markets.

Allow our products and services to win you over.



Up-to-date + compact

All product information can be downloaded from
www.vogel-antriebe.de

C O N T E N T S

Product finder	Page 4
Company	Page 6
Dimensioning	Page 16
Product data	Page 22

COAXIAL	Low backlash gearboxes	from page 22	MPR, MPRN, MPRW Page 24
			MPG Page 42
			MPL Page 58

ANGULAR	Servo spiral bevel gearboxes	from page 68	SK, SKN Page 70
			SKH Page 76
			SKPR, SKPRN Page 82
	Spiral bevel gearboxes	from page 100	SKPG Page 90
			ML Page 100
			MH Page 106
	Bevel helical gearboxes	from page 116	MH with shrink disc Page 110
			MKS Page 118
			MKSH Page 124
		MKSHF with output flange Page 130	
		MKSH hollow shaft with shrink disc Page 131	

Distribution partners, contact, order	Page 134
--	----------

Information and liability exclusion:

All contents contained within our catalogue including its design are protected by copyright. Text and images used within our catalogue were made available and approved for use by Wilhelm VOGEL GmbH Antriebstechnik. All rights are owned by Wilhelm VOGEL GmbH Antriebstechnik. No responsibility is taken for the correctness of information provided. All information is intended exclusively for private use – commercial use of editorial descriptions and structuring is prohibited. Commercial use of data is also prohibited, e.g. for the construction of own systems and services or directories of any type. No responsibility or liability is assumed for information contained within this catalogue. No form of legal counsel should ensue according to the information contained within this catalogue.

PRODUCT MATRIX

				Coaxial gearboxes		
				Low backlash planetary gearboxes		
						
				from page 24	from page 42	from page 58
Gearbox type			MPR	MPG	MPL	
	Symbol	Unit				
Gearbox figures	Ratios	i	[-]	3 to 100	4 to 100	3 to 100
	Max. acceleration torque	T_{2bzul}	[Nm]	44 to 1900	44 to 1900	40 to 500
	Nominal torque	T_{2Nzul}	[Nm]	29 to 1000	29 to 1000	25 to 360
	Max. backlash	j	[arcmin]	1 to 8	1 to 8	8 to 10
	Max. input speed	$n_{1maxzul}$	[min ⁻¹]	3500 to 6000	3500 to 6000	4500 to 8000
Output variants	Solid shaft with key	-	[-]	○	-	●
	Solid shaft without key	-	[-]	●	-	○
	Splined shaft DIN 5480	-	[-]	○	-	-
	Hollow shaft with keyway	-	[-]	-	-	-
	Hollow shaft with shrink disc	-	[-]	-	-	-
	Flanged shaft	-	[-]	-	●	-
	Output flange	-	[-]	-	-	-
ATEX design	-	[-]	-	-	-	

- marks the standard design
- marks optionally available designs

Note on use in potentially explosive areas:

European Guideline 94/9/EC for equipment for use in potentially explosive areas (ATEX).
 VOGEL spiral bevel gearboxes and VOGEL bevel helical gearboxes are available in an explosion-proof version

Zone Gas	Zone Dust
1	21
2	22

Covered by ATEX gearboxes of the category II 2GD c,k IIB T4 / 120 °C

Angular gearboxes

Servo spiral bevel gearboxes				Spiral bevel gearboxes		Bevel helical gearboxes	
							
from page 70	from page 76	from page 82	from page 90	from page 102	from page 108	from page 118	from page 124
SK	SKH	SKPR	SKPG	ML	MH	MKS	MKSH
3 to 10	3 to 10	12 to 100	12 to 100	3 to 6	3 to 6	6 to 48	6 to 48
54 to 217	54 to 217	100 to 950	100 to 950	18 to 100	18 to 100	130 to 460	130 to 460
40 to 150	40 to 150	70 to 550	70 to 550	12 to 75	12 to 75	110 to 400	110 to 400
2 to 5	2 to 5	3 to 5	3 to 5	4 to 7	4 to 7	4	4
6500 to 7500	6500 to 7500	6500 to 7500	6500 to 7500	5000	5000	5000	5000
○	-	○	-	●	-	●	-
●	-	●	-	○	-	○	-
-	-	-	-	-	-	-	-
-	-	-	-	-	●	-	●
-	●	-	-	-	○	-	○
-	-	-	●	-	-	-	-
-	-	-	-	-	-	-	○
-	-	-	-	○	○	○	○

● marks the standard design
○ marks optionally available designs



FUTURE IN MOTION

Continuity and development are mutually dependent cornerstones of our corporate tradition. For the past 60 years we have been constantly committed to products and markets with maximum quality consciousness. As a mid-sized, family owned company this sense of continuity is highly important to us; the executive management in its third generation accepts personal responsibility for this.



On the other hand we actively determine the future of gearbox manufacturing through our technological developments, thus ensuring market capability for our customers. Because the only valid constant is change.

PARTNERSHIP FOR TECHNOLOGY

Efficiency and safety from initial discussions of a project to the finished product and beyond – that is the target of our offensive with respect to quality and service management. We initially carry out a thorough, detailed consultation individually in accordance with the requirements of your application. Once the ideal solution is decided upon, we produce flexibly and on schedule, precisely in accordance with your requirements.

Our customers rightly expect smooth and uninterrupted manufacturing processes. You can count on an almost maintenance-free product over the entire life cycle when using VOGEL gearboxes.

Should you still require our support at some stage, there is a world-wide service network available to assist you as soon as possible with a replacement gearbox or an on-site repair. To keep your production line running!



COMPETENCE IN THE MARKET

VOGEL Antriebstechnik is found everywhere where machinery is built, in all sectors and at all sites. Wherever you manufacture, we will be at your side.

Internationally, our customers are looked after by our distribution and service partner Lenze. That means we have a presence in the important markets and you benefit globally from direct access to our expertise and product ranges.





INDUSTRY SOLUTIONS

With VOGEL you stay flexible. For example our modular gearbox system offers you the widest variety of combination possibilities. On the basis of these product standards we can also offer you the desired modifications needed for your field of activity. It goes without saying that such services are cost-

optimised and in accordance with your specifications. For unusual requirements we offer entirely individual solutions. In such cases we assess application conditions in cooperation with you, advise you reliably and construct special gearboxes for you, including gear manufacturing.

S U C C E S S F U L A P P L I C A T I O N S

Our gearboxes have a broad and constantly increasing range of applications.

- Drive and automation engineering
- Robotics and handling
- Packaging machinery
- Plastics and film processing machines
- Printing machinery
- Paper processing
- Machine tools
- The food and pharmaceutical industry

and many more

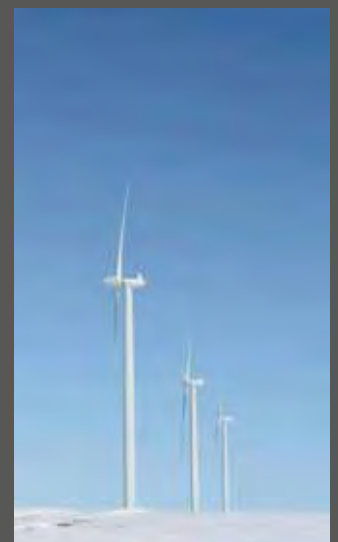

PRODUCT RANGE

The range of VOGEL Antriebstechnik offers nominal output torques of between 10 Nm and 26000 Nm. Our range of standard solutions extends from classic machinery gearboxes, through compact technology for coaxial and right-angle applications, to our own high-precision servo

products. Always in mind: dynamic development of all existing series with the aim of creating optimum drives for our customers, technologically and thus economically.



Low backlash planetary gearboxes

Ratio:
3 – 100
Output torque:
15 – 1000 Nm

- Universal application with especially compact design, symmetrical construction and an adaptable motor connection
- Less noise generated
- For high acceleration torques

Rack & Pinion Drive

Ratio:
15 – 27
Output torque:
29 – 850 Nm

- Combination of low backlash planetary gearbox with high precision racks & pinions
- Compact transmission of high torques
- Minimal installation effort and fast startup
- High precision, load capacity and level of concentricity

Servo-bevel gearboxes

Ratio:
3 – 10
Output torque:
40 – 150 Nm

- For the toughest demands in dynamics
- Flexible
- Robust and durable
- For any mounting position due to flexible lubrication system

Bevel helical gearboxes

Ratio:
6 – 48
Output torque:
100 – 13000 Nm

- In eight sizes – universal application
- Easy handling
- Quiet running
- High power density
- Available in different types

All VOGEL gearboxes can be combined with each other. In this way you benefit from the advantages of various gearbox types.



Spiral bevel gearboxes

Ratio:
0,5 – 6
Output torque:
10 – 8500 Nm

- Universal application
- Easy to install and adapt
- Designed with the machine in mind
- Efficient and reliable
- Available in different types



Planetary gearboxes

Ratio:
3,4 – 245
Output torque:
up to 26000 Nm

- For higher torque requirements with a compact design
- Compact drive technology for coaxial applications requiring especially high power densities
- Smooth-running even at high speeds



Customer-specific solutions

- Special spiral bevel gearboxes
 - Special solution for mobile drive technology
 - Special planetary gearboxes for high-speed applications
 - Gearing technology
- and many more



Q U A L I T Y

Our internal high standards of quality often far exceed those commonly found in the industry. Because of this extensive and consistent quality control, we are in a position to offer you especially reliable, low-maintenance and durable gearboxes, a factor confirmed again and again in dialogue with our long-term customers.

Our extensive manufacturing expertise within development and production, guarantees noise- and torque-optimised gearing technology at the highest standards. Upon request we can also supply inspection reports or certification for any gearbox, e.g. with respect to run-out error or backlash.

In this way we ensure for you:

- Highest levels of precision and dynamics
- Long product life
- Maximum flexibility
- Maximum environmental compatibility
- Minimal effort for the complete life cycle
- Unbeatable efficiency
- Excellent energy efficiency



C O N S U L T A T I O N

In every phase of collaboration with VOGEL you benefit from our unique sector-specific expertise, gathered over decades in close cooperation with our national and international partners. We develop concepts together with you for the cost-effective solutions of your application. In this respect we initially analyse and determine the most important environmental parameters such as application conditions, loads, duration of operation, speeds, motion sequences etc. in order to find the best product solution.

S E R V I C E

Together with our service and distribution partners we make sure that we are there when you need us, whether for supply of parts, repairs and service or technical support, both on a national scale and internationally.



C O M M U N I C A T I O N

Up-to-date and comprehensive product information, service manuals, catalogues, technical documentation, contact data and quality documents are available to you in a variety of languages via our website. In addition we can provide you with the relevant information on CD-ROM. For technical data exchange we offer over 100 different interfaces and guarantee support for all globally current CAD software programmes, thus shortening development cycles.

T R A I N I N G

Upon request you can take advantage of individual product and service training as well as general educational courses on drive and automation technology. In addition, we are also always pleased to inform you of intelligent maintenance strategies that will optimise your manufacturing performance. Simply contact our service team.

S E R V I C E S

P R E C I S I O N

Maximum precision in every detail – that is what sets all VOGEL gearboxes apart. From optimised product geometry and highly precise, fine ground gear teeth to careful mounting. With improved design and minimised tolerances we achieve a remarkably high torsional and tilting rigidity with minimal noise emission and unbeatably quiet running.

F L E X I B I L I T Y

Thanks to their practical design and intelligent construction, our low backlash gearboxes can be used variably across a very wide spectrum of applications. With a large selection of motor adapters, multiple drive combinations are possible. A large ratio range with fine increments renders them absolute all-rounders for all sectors.

C O S T - E F F I C I E N C Y

A high level of efficiency for maximum cost-effectiveness. With optimised concentration on the smallest possible shaft diameter, we achieve efficient results without friction losses and therefore without loss of energy. Economically, VOGEL also convinces with extremely simple motor mounting – thus saving time, which in turn decisively aids your manufacturing processes.

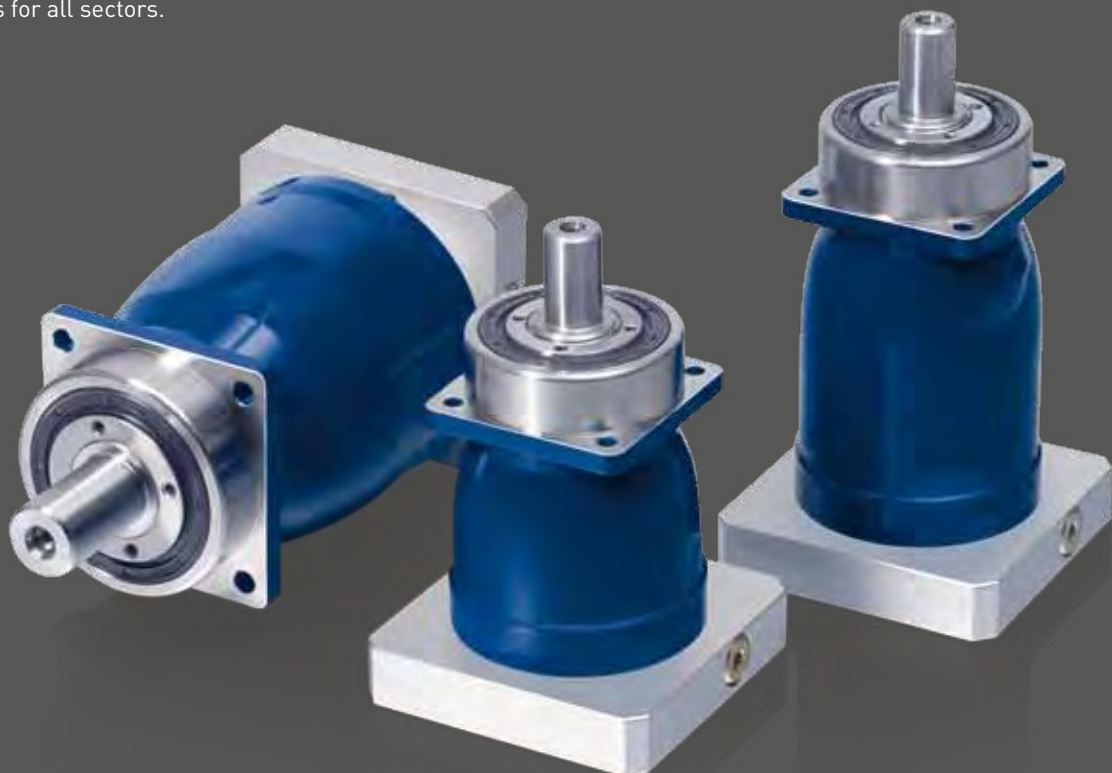



D U R A B I L I T Y

We place particular emphasis on high quality for all materials, components and parts used. In doing so we are able to guarantee maintenance-free, reliable operation as well as maximum service life even under very high operational stress. Optimal lubrication of gearboxes is guaranteed.

C O M P A C T N E S S

A compact design, short overall lengths – VOGEL Antriebs-technik offers performance and efficiency on a highly compact scale. This is made possible in no small way by helical gear teeth, allowing greater torques with uniform and low-noise drive motion.

D Y N A M I C S

With strengthened bearings our gearboxes are able to withstand high forces – even with high speeds and in extreme cases when overloaded. This is possible by the implementation of full needle bearings. Low gearbox weight, combined with compact construction offers enhanced inertia values – further proof of the dynamics of our gearboxes.

D I M E N S I O N I N G A N D S E L E C T I O N

Investigation of a gearbox to determine suitability for an application can be carried out by comparison of maximum possible motor torques and gearbox data. In this case the applications are differentiated according to EN 60034-1 with operating mode continuous operation (S1) and cyclic operation (S4/S5). For cyclic operation, the maximum motor acceleration torque

is used. For continuous operation the nominal motor torque is taken into consideration. If the maximum possible motor torque exceeds permissible values of the required gearbox, a recalculation involving the torques actually required by the application must be carried out.

Mounting advice

All specifications are valid for the following ambient conditions:

- No heating of gearbox by the motor
- Mounting plate size /square = 2 x gearbox size
- Mounting plate material = steel
- Unobstructed thermal convection / no housing encloses gearbox
- Ambient temperature = maximum +30 °C
- The operating mode is S5
Please contact us if you intend to use other operating modes

Formula symbols and indices

Designation	Unit	Symbol	Designation	Unit	Symbol	Designation	Indices
Rigidity	Nm/arcmin	C	Factor for bearing calculation	-	p	Permissible values	zul
Duty cycle	%	ED	Efficiency	%	η	Input	1
Runtime	min	EZ	Time	s	t	Output	2
Load	N	F	Torque	Nm	T	Axial	a
Dynamics factor	-	k	Distance of lateral force to shaft collar	mm	x	Acceleration	b
Ratio	-	i	Distance of axial force to gearbox centre	mm	y	Hours	h
Backlash	arcmin	j	Distance for bearing calculation	mm	a	Average	m
Inertia	kgcm ²	J	No. of cycles	1/h	Z	Minimum	min
Factor for bearing calculation	-	KL	Screw clamping torque	Nm	MA	Maximum	max
Factor for bearing calculation	-	f	Length	mm	L, l	Nominal	N
Live time	h	L _{10h}	Diameter	mm	D, d	Emergency stop	Not
Running noise	dB(A)	L _{PA}				Radial	r
Mass	kg	m				Motor	Mot
Tilting moment	Nm	MK				Output shaft	W
Speed	min ⁻¹	n				Output bearings	L

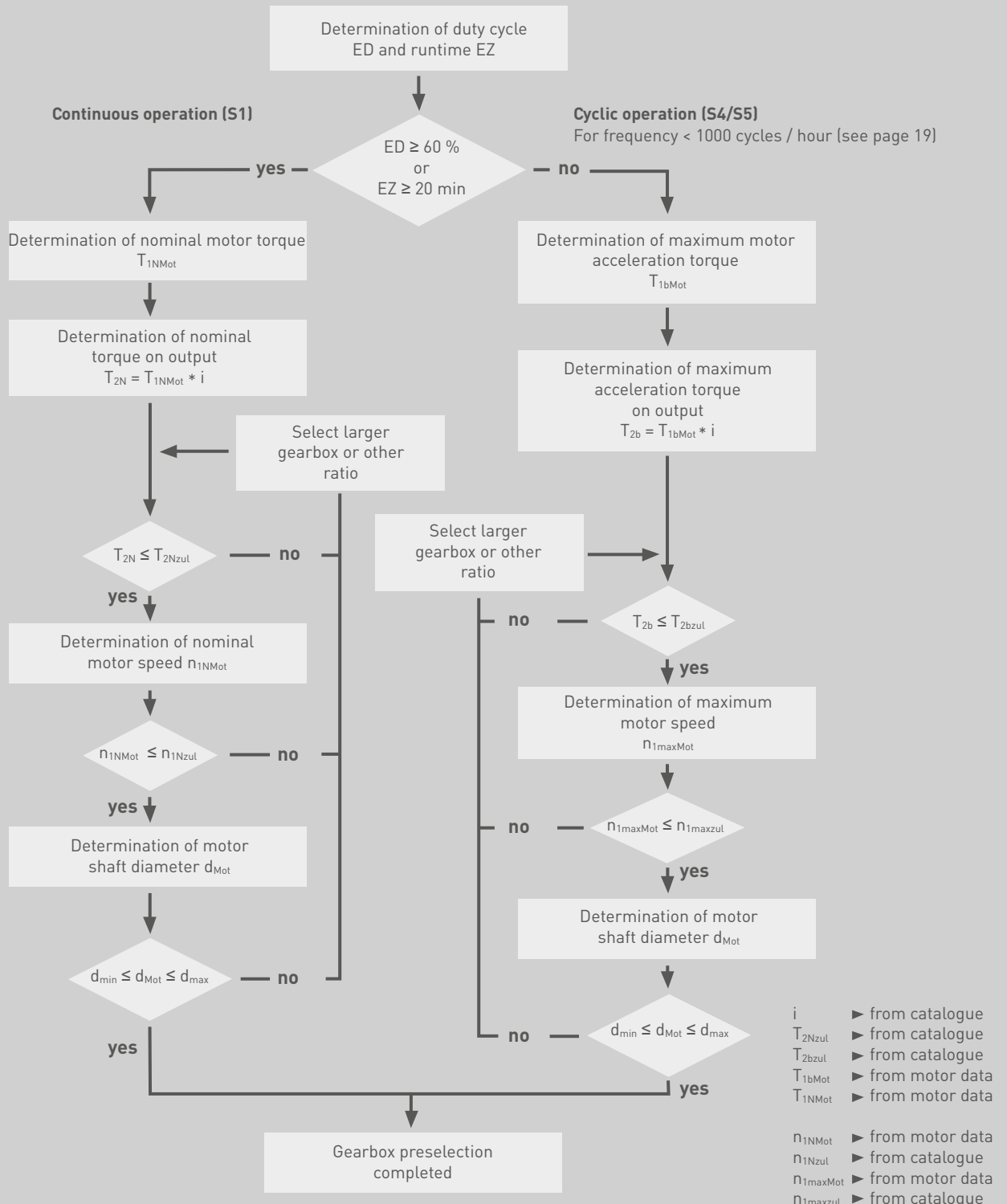

DETAILED GEARBOX SELECTION

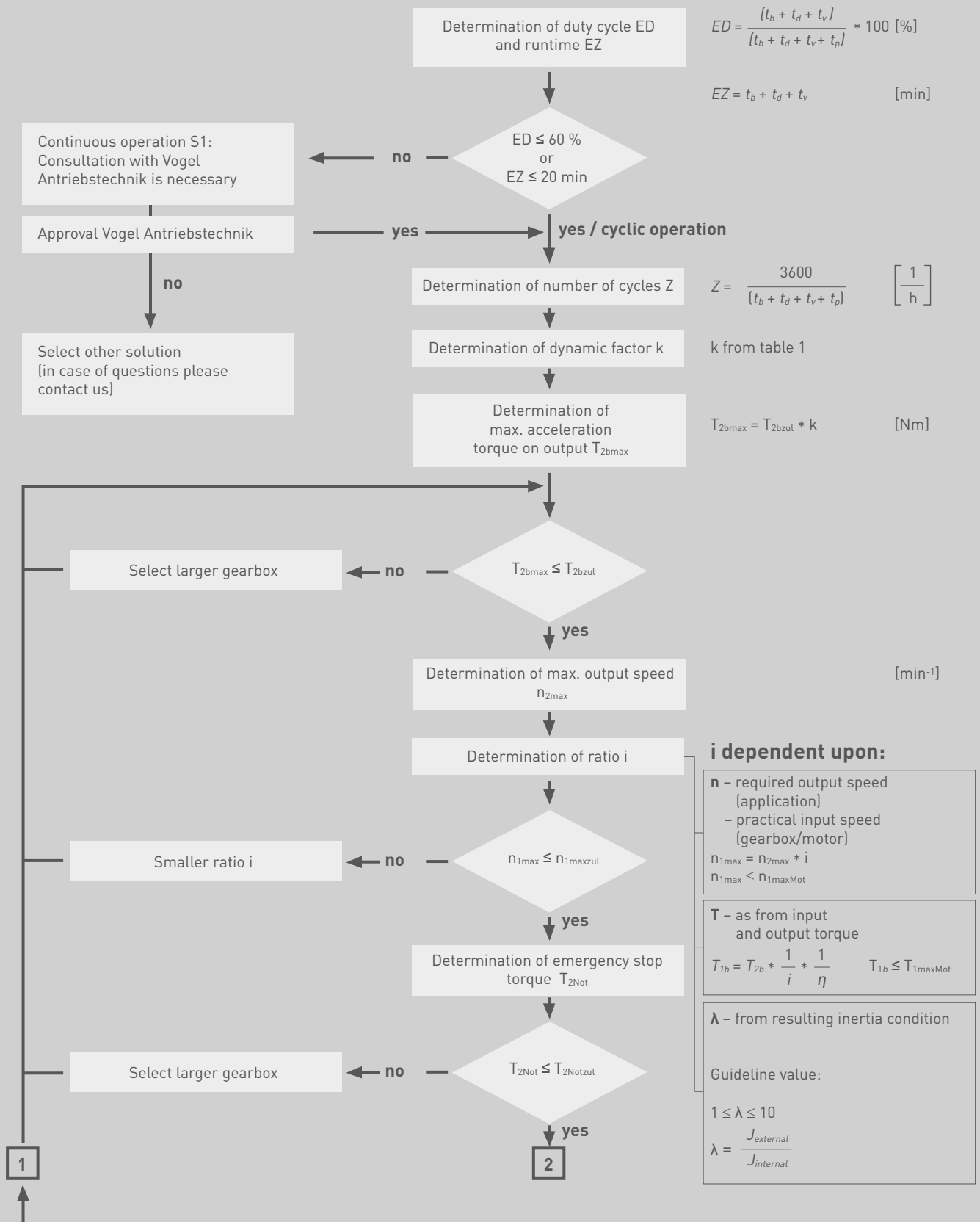

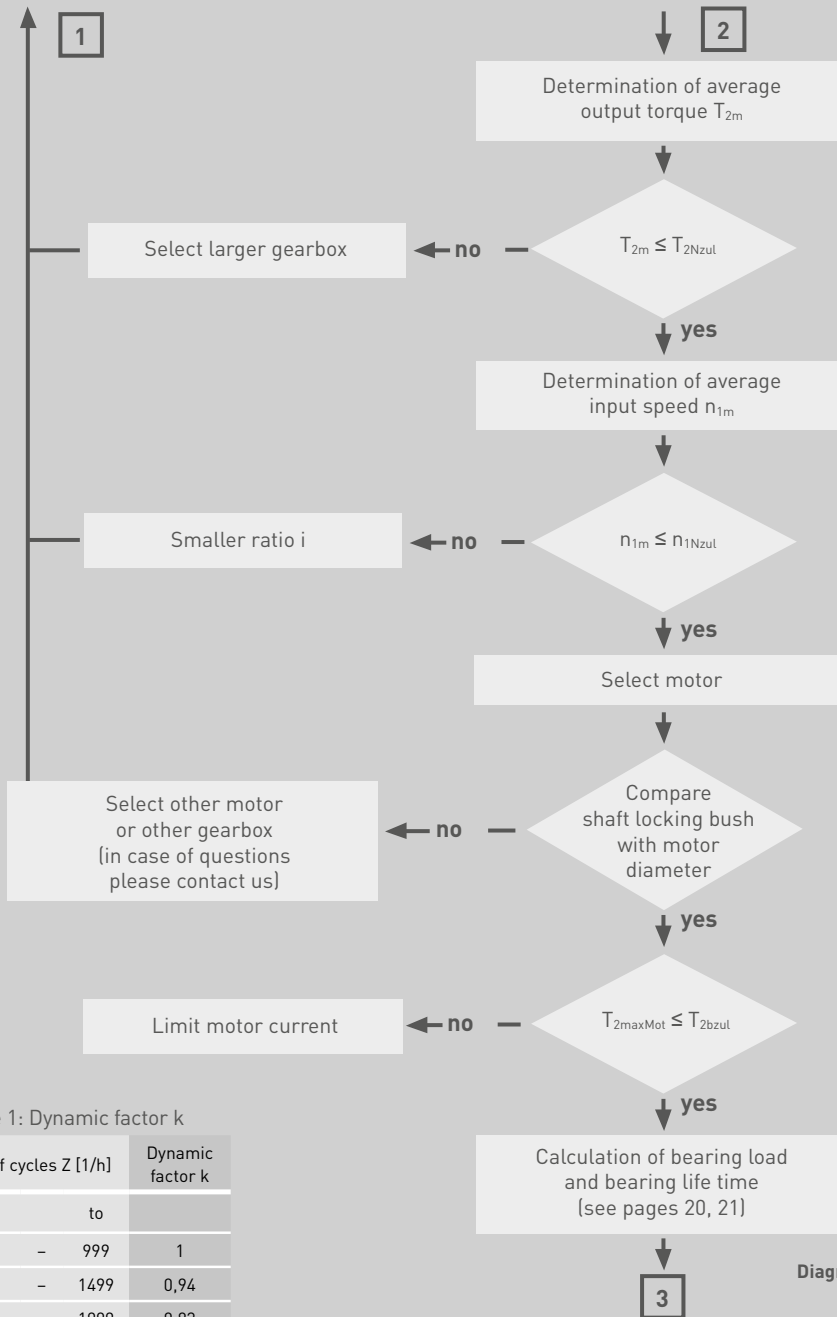

$$T_{2m} = \sqrt[3]{\frac{|n_{2b} * t_b * T_{2b}^3| + \dots + |n_{2v} * t_v * T_{2v}^3|}{|n_{2b} * t_b| + \dots + |n_{2v} * t_v|}} \text{ [Nm]}$$

$$n_{1m} = n_{2m} * i$$

$$n_{2m} = \frac{|n_{2b} * t_b| + \dots + |n_{2v} * t_v|}{t_b + \dots + t_v} \text{ [min}^{-1}\text{]}$$

include. idle time

$$d_{min} \leq d_{Mot} \leq d_{max}$$

The motor shaft must fit in the shaft locking bush. Motor shaft length: see dimensional drawings

$$T_{2maxMot} = T_{1maxMot} * i * \eta_{Getriebe}$$

With motor at full load, the gearbox must not become damaged; limit motor current if applicable.

Table 1: Dynamic factor k

No. of cycles Z [1/h]		Dynamic factor k
from	to	
0	- 999	1
1000	- 1499	0,94
1500	- 1999	0,83
2000	- 2499	0,75
2500	- 2999	0,68
3000	- 3499	0,63
3500	- 3999	0,59
4000	- 4499	0,56
4500	- 4999	0,53
5000	- 5499	0,51
5500	- 5999	0,5
6000	- 6499	0,49
6500	- 6999	0,48
7000	- 7499	0,47
7500	- ~	0,46

Diagram 1: Load profile on output

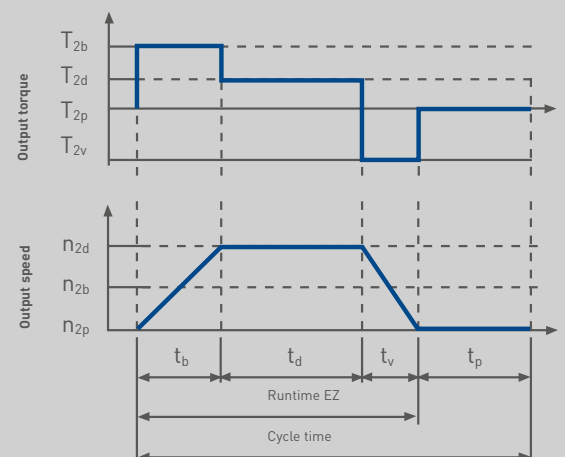

DETAILED GEARBOX SELECTION PERMISSIBLE LOAD ON OUTPUT

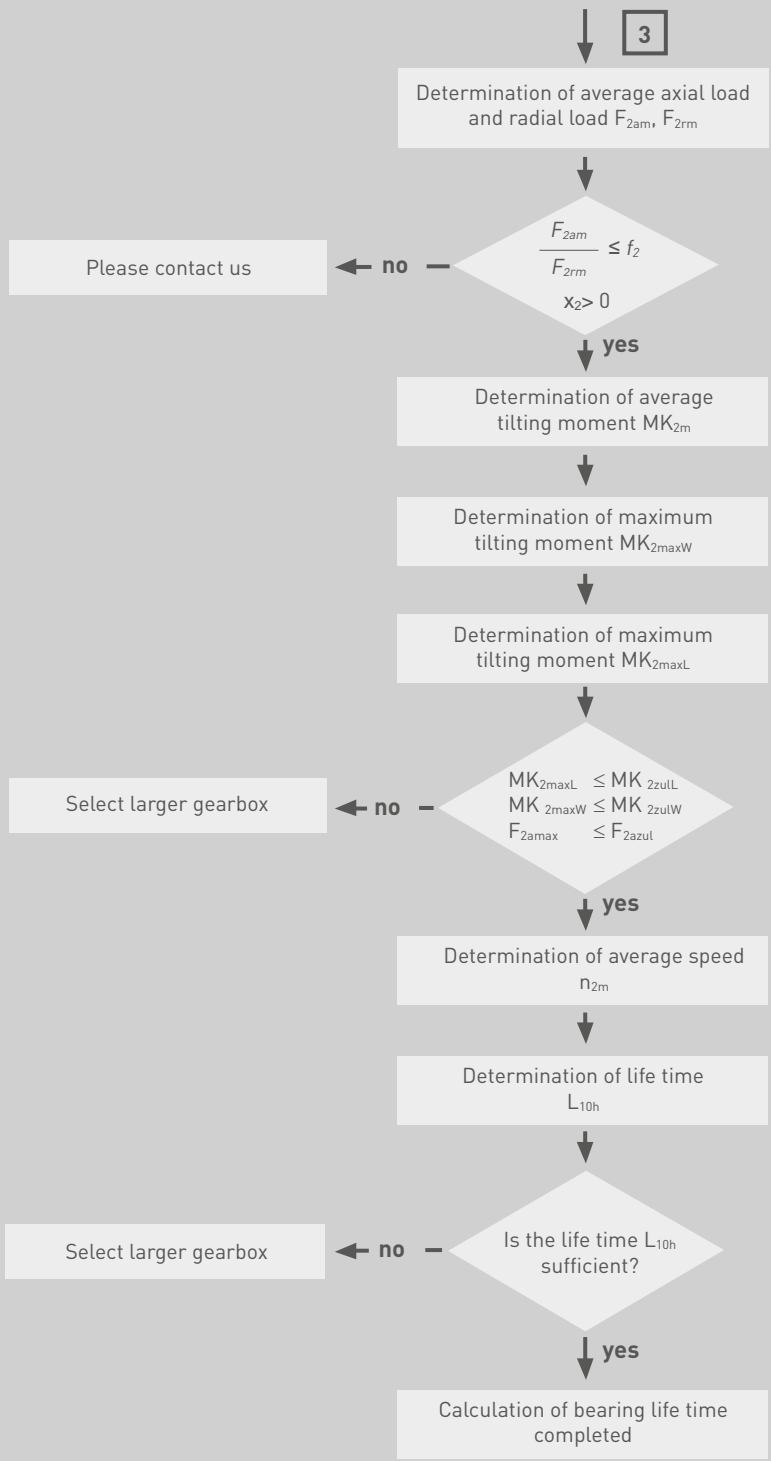

$$F_{2am} = \sqrt[3]{\frac{|n_{2b} * t_b * F_{2ab}|^3 + \dots + |n_{2v} * t_v * F_{2av}|^3}{|n_{2b} * t_b| + \dots + |n_{2v} * t_v|}} \quad [N]$$

$$F_{2rm} = \sqrt[3]{\frac{|n_{2b} * t_b * F_{2rb}|^3 + \dots + |n_{2v} * t_v * F_{2rv}|^3}{|n_{2b} * t_b| + \dots + |n_{2v} * t_v|}} \quad [N]$$

$$MK_{2m} = \frac{F_{2am} * y_2 + F_{2rm} * (a_2 + x_2)}{1000} \quad [Nm] \quad ^{1)}$$

$$MK_{2maxW} = \frac{F_{2amax} * y_2 + F_{2rmax} * x_2}{1000} \quad [Nm] \quad ^{1, 2)}$$

$$MK_{2maxL} = \frac{F_{2amax} * y_2 + F_{2rmax} * (a_2 + x_2)}{1000} \quad [Nm] \quad ^{1)}$$

¹⁾ a₂, x₂, y₂ in mm, see page 21
²⁾ calculation for MPR and MPL

$$n_{2m} = \frac{|n_{2b} * t_b| + \dots + |n_{2v} * t_v|}{t_b + \dots + t_v} \quad [min^{-1}]$$

$$L_{10h} = \frac{16666}{n_{2m}} * \left[\frac{KL_2}{MK_{2m}} \right]^{P_2} \quad [h]$$

COAXIAL GEARBOXES *

Gearbox type		MPR					
Gearbox size		050	100	200	300	04	05
f_2		0,40	0,40	0,40	0,40	0,40	0,40
a_2	mm	40,3	47,1	57,8	76,5	69,4	90,9
MK_{2zuIL}	Nm	147	261	547	1111	1546	2581
MK_{2zuIW}	Nm	38	72	183	388	574	945
KL_2		810	1230	2625	5360	5605	11750
p_2		3,33	3,33	3,33	3,33	3,33	3,33

Gearbox type		MPG					
Gearbox size		050	100	200	300	04	05
f_2		0,37	1,14	0,37	0,37	0,37	0,37
a_2	mm	60,8	75,0	100,5	81,3	96,0	107,9
MK_{2zuIL}	Nm	115	250	463	1337	2078	2617
KL_2		558	1015	1995	3920	7725	9740
p_2		3,33	3,00	3,33	3,33	3,33	3,33

Gearbox type		MPL			
Gearbox size		050	100	200	300
f_2		0,24	0,24	0,24	0,24
a_2	mm	28,7	31,2	40,2	46,7
MK_{2zuIL}	Nm	62	119	319	658
MK_{2zuIW}	Nm	20	43	134	308
KL_2		255	312	848	1610
p_2		3,00	3,00	3,00	3,00

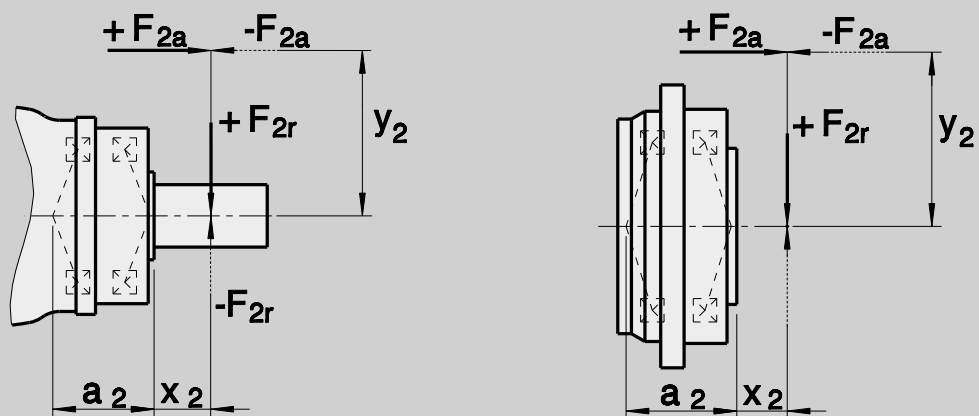

* Angular gearboxes, please contact us.

COAXIAL

LOW BACKLASH PLANETARY GEARBOXES

The planetary gearbox consists of the coaxial sun gear, planet carrier and outer gear sub-assemblies, and is combined with the planet gears rotating at constant centres about the planet carrier. The input is from the sun gear. The drive motion to the planet carrier (output shaft) is via the planet gears. The rolling contact of the planet gears with the outer gear provi-

des the appropriate ratio. Multi-stage gearboxes are available by connecting the individual stages in sequence. Within the gear assembly the individual stages are sized to their torque requirement.

MPR					
050	100	200	300	04	05
Page 25	Page 25	Page 26	Page 26	Page 27	Page 27

MPG					
050	100	200	300	04	05
Page 43	Page 43	Page 44	Page 44	Page 45	Page 45

MPL			
00	01	02	03
Page 59	Page 59	Page 60	Page 61



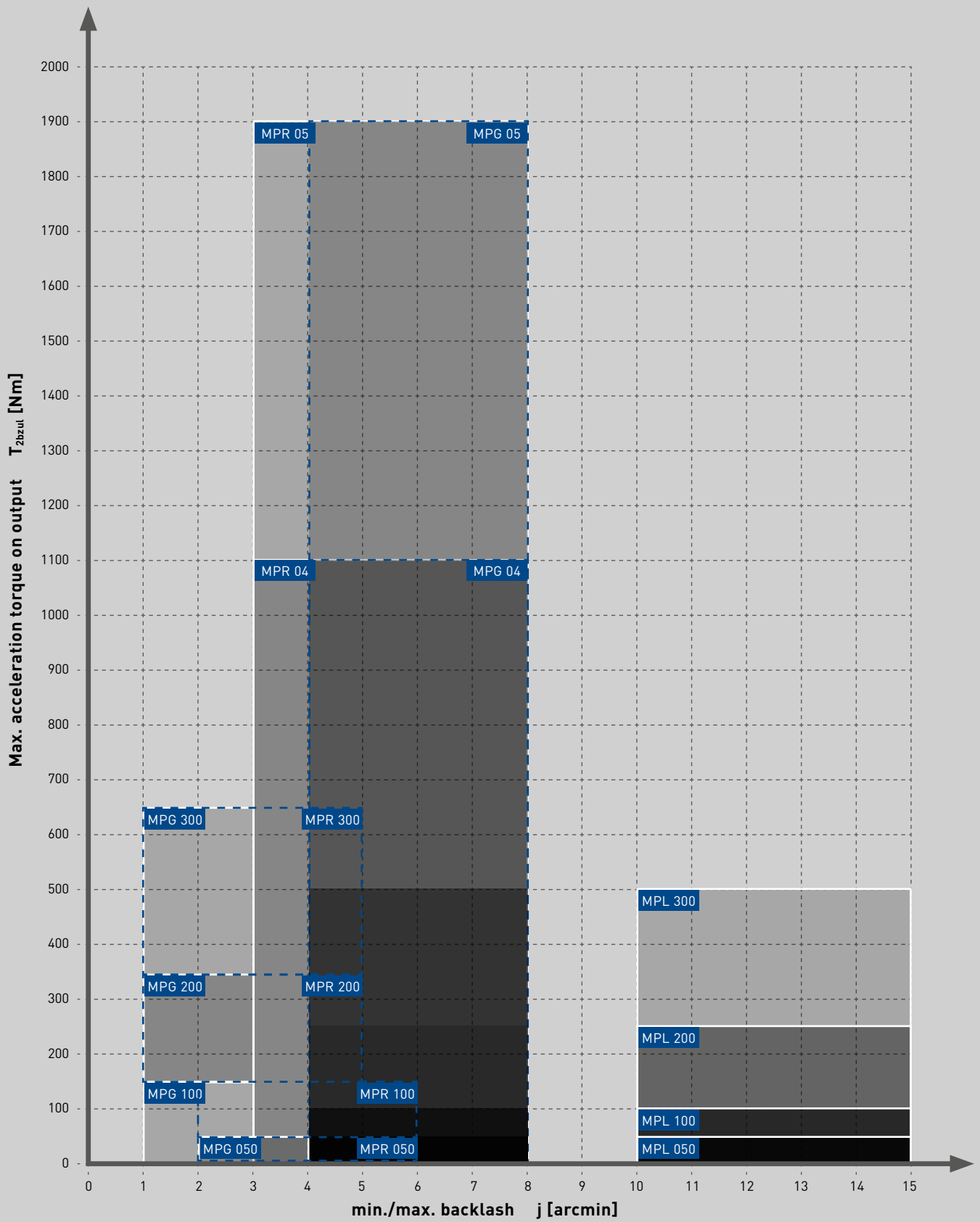

MPR(N)

TECHNICAL DATA

Technical specifications on this page and in the tables on the following three pages are intended only for rough preselection.

Gear teeth:	MPR 050 - 300 helical gear MPR 04 - 05 spur gear	Lubrication:	lubricated for life
Direction of rotation:	input and output in the same direction	Mounting position:	MPR 050 - 300 any, can be changed at any time
Efficiency:	1-stage $\eta \geq 97\%$ 2-stage $\eta \geq 95\%$		MPR 04 - 05 any, please specify when ordering
Life time:	20000 h	Surface protection:	Primer coat RAL 9005 black
Permissible gearbox temperature at housing:	-10 °C to +90 °C	Protection rating:	IP65





MPR(N) 050 - MPR(N) 100

TECHNICAL DATA

The following technical specifications in the table are intended only for rough preselection

MPR			050															
Gear stages			1					2										
Ratio	i		3	4	5	7	10	12	16	20	25	28	35	40	50	70	100	
Max. acceleration torque (max. 1000 cycles per hour)	T_{2bzul}	Nm	32	44	44	44	35	32	44	44	44	44	44	44	44	44	35	
Nominal torque on output (with n_{1Nzul})	T_{2Nzul}	Nm	20	29	29	29	19	20	29	29	29	29	29	29	29	29	19	
Emergency stop torque (permissible 1000 times during gearbox life time)	$T_{2Notzul}$	Nm	80	110	110	107	88	80	110	110	110	110	110	110	110	107	88	
Permissible average input speed (with T_{2bzul} and 20 °C ambient temperature)	n_{1mzul}	min ⁻¹	3300	3300	3300	3700	4000	4000	4400	4400	4400	4400	4400	4400	4800	5500	5500	
Max. input speed	$n_{1maxzul}$	min ⁻¹	6000					6000										
Max. backlash*	j	arcmin	standard ≤ 4 / reduced ≤ 2					standard ≤ 6 / reduced ≤ 4										
Torsional rigidity [▲]	C	Nm/arcmin	5					5										
Max. radial load** (with reference to shaft centre on output shaft)	F_{2rzul}	N	2700					2700										
Max. axial load** (with reference to shaft centre on output shaft)	F_{2azul}	N	2400					2400										
Weight	m	kg	2,1					2,7										
Running noise (with $n_1 = 3000$ min ⁻¹ without load)	L_{PA}	dB(A)	≤ 64					≤ 64										
Inertia (with reference to input)	Ø d 11	J_1	kgcm ²	0,33	0,24	0,20	0,18	0,16	0,21	0,21	0,18	0,18	0,17	0,17	0,16	0,16	0,16	0,16
	Ø d 14	J_1	kgcm ²	0,36	0,27	0,23	0,21	0,19	0,25	0,24	0,21	0,21	0,20	0,20	0,19	0,19	0,19	0,19
	Ø d 19	J_1	kgcm ²	0,53	0,44	0,40	0,34	0,33	-	-	-	-	-	-	-	-	-	-

MPR			100															
Gear stages			1					2										
Ratio	i		3	4	5	7	10	12	16	20	25	28	35	40	50	70	100	
Max. acceleration torque (max. 1000 cycles per hour)	T_{2bzul}	Nm	90	120	120	120	90	90	120	120	120	120	120	120	120	120	90	
Nominal torque on output (with n_{1Nzul})	T_{2Nzul}	Nm	56	83	83	83	58	56	83	83	83	83	83	76	83	83	58	
Emergency stop torque (permissible 1000 times during gearbox life time)	$T_{2Notzul}$	Nm	200	275	275	275	220	200	275	275	275	275	275	275	275	275	220	
Permissible average input speed (with T_{2bzul} and 20 °C ambient temperature)	n_{1mzul}	min ⁻¹	2800	2800	2800	2800	3100	3100	3500	3500	3500	3500	3500	3500	3800	4500	4500	
Max. input speed	$n_{1maxzul}$	min ⁻¹	6000					6000										
Max. backlash*	j	arcmin	standard ≤ 4 / reduced ≤ 2					standard ≤ 6 / reduced ≤ 4										
Torsional rigidity [▲]	C	Nm/arcmin	11					11										
Max. radial load** (with reference to shaft centre on output shaft)	F_{2rzul}	N	4000					4000										
Max. axial load** (with reference to shaft centre on output shaft)	F_{2azul}	N	3350					3350										
Weight	m	kg	3,1					4,4										
Running noise (with $n_1 = 3000$ min ⁻¹ without load)	L_{PA}	dB(A)	≤ 64					≤ 64										
Inertia (with reference to input)	Ø d 11	J_1	kgcm ²	1,03	0,70	0,58	0,48	0,43	0,25	0,23	0,19	0,19	0,17	0,17	0,16	0,16	0,16	0,16
	Ø d 14	J_1	kgcm ²	1,07	0,74	0,62	0,52	0,47	0,29	0,26	0,22	0,22	0,20	0,20	0,19	0,19	0,19	0,19
	Ø d 19	J_1	kgcm ²	1,21	0,88	0,76	0,67	0,62	-	-	-	-	-	-	-	-	-	-
	Ø d 24	J_1	kgcm ²	1,92	1,59	1,47	1,37	1,32	-	-	-	-	-	-	-	-	-	-

▲with reference to output

* measured with 2 % nominal torque on output shaft

**charge centre of output shaft at output speed 250 min⁻¹. Please contact us for combined load applications

MPR(N) 200 - MPR(N) 300

TECHNICAL DATA

MPR			200															
Gear stages			1					2										
Ratio	i		3	4	5	7	10	12	16	20	25	28	35	40	50	70	100	
Max. acceleration torque (max. 1000 cycles per hour)	T _{2bzul}	Nm	230	330	330	300	235	230	330	330	330	330	330	330	330	330	235	
Nominal torque on output (with n _{1Nzul})	T _{2Nzul}	Nm	135	200	195	190	135	135	200	195	195	200	195	200	195	190	135	
Emergency stop torque (permissible 1000 times during gearbox life time)	T _{2Notzul}	Nm	500	690	675	640	550	500	690	675	675	690	675	690	675	640	550	
Permissible average input speed (with T _{2bzul} and 20 °C ambient temperature)	n _{1mzul}	min ⁻¹	2500	2500	2500	2800	2800	2800	3100	3100	3100	3100	3100	3100	3100	3500	4200	
Max. input speed	n _{1maxzul}	min ⁻¹	4500					4500										
Max. backlash*	j	arcmin	standard ≤ 3 / reduced ≤ 1					standard ≤ 5 / reduced ≤ 3										
Torsional rigidity [▲]	C	Nm/arcmin	30					30										
Max. radial load** (with reference to shaft centre on output shaft)	F _{2rzul}	N	6300					6300										
Max. axial load** (with reference to shaft centre on output shaft)	F _{2azul}	N	5650					5650										
Weight	m	kg	7,3					8,3										
Running noise (with n ₁ = 3000 min ⁻¹ without load)	L _{PA}	dB(A)	≤ 66					≤ 64										
Inertia (with reference to input)	Ø d 11	J ₁	kgcm ²	-	-	-	-	-	0,80	0,72	0,58	0,56	0,48	0,47	0,44	0,43	0,43	0,42
	Ø d 14	J ₁	kgcm ²	-	-	-	-	-	0,84	0,76	0,61	0,60	0,52	0,51	0,47	0,46	0,46	0,46
	Ø d 19	J ₁	kgcm ²	4,48	3,23	2,78	2,42	2,23	0,98	0,90	0,76	0,74	0,66	0,65	0,62	0,61	0,61	0,60
	Ø d 24	J ₁	kgcm ²	5,00	3,75	3,30	2,94	2,75	-	-	-	-	-	-	-	-	-	-
	Ø d 28	J ₁	kgcm ²	6,80	5,56	5,10	4,74	4,55	-	-	-	-	-	-	-	-	-	-
	Ø d 32	J ₁	kgcm ²	7,09	5,84	5,39	5,02	4,83	-	-	-	-	-	-	-	-	-	-
	Ø d 38	J ₁	kgcm ²	8,94	7,69	7,24	6,85	6,67	-	-	-	-	-	-	-	-	-	-

MPR			300															
Gear stages			1					2										
Ratio	i		3	4	5	7	10	12	16	20	25	28	35	40	50	70	100	
Max. acceleration torque (max. 1000 cycles per hour)	T _{2bzul}	Nm	400	660	660	600	480	400	660	660	660	660	660	660	660	600	480	
Nominal torque on output (with n _{1Nzul})	T _{2Nzul}	Nm	290	390	390	380	245	290	390	390	390	390	390	390	390	380	245	
Emergency stop torque (permissible 1000 times during gearbox life time)	T _{2Notzul}	Nm	1000	1400	1400	1400	1100	1000	1400	1400	1400	1400	1400	1400	1400	1400	1100	
Permissible average input speed (with T _{2bzul} and 20 °C ambient temperature)	n _{1mzul}	min ⁻¹	2100	2100	2100	2300	2600	2600	2900	2900	2900	2900	2900	2900	2900	3200	3900	
Max. input speed	n _{1maxzul}	min ⁻¹	4000					4000										
Max. backlash*	j	arcmin	standard ≤ 3 / reduced ≤ 1					standard ≤ 5 / reduced ≤ 3										
Torsional rigidity [▲]	C	Nm/arcmin	60					60										
Max. radial load** (with reference to shaft centre on output shaft)	F _{2rzul}	N	9450					9450										
Max. axial load** (with reference to shaft centre on output shaft)	F _{2azul}	N	9870					9870										
Weight	m	kg	17,3					19,0										
Running noise (with n ₁ = 3000 min ⁻¹ without load)	L _{PA}	dB(A)	≤ 66					≤ 65										
Inertia (with reference to input)	Ø d 19	J ₁	kgcm ²	-	-	-	-	-	2,70	2,46	2,26	2,20	2,14	2,12	2,11	2,08	2,07	2,06
	Ø d 24	J ₁	kgcm ²	13,54	9,72	8,27	7,14	6,46	3,22	2,98	2,78	2,72	2,66	2,63	2,62	2,59	2,58	2,58
	Ø d 28	J ₁	kgcm ²	15,30	11,49	10,04	8,89	8,22	5,02	4,78	4,58	4,53	4,46	4,43	4,42	4,39	4,38	4,38
	Ø d 32	J ₁	kgcm ²	15,61	11,79	10,34	9,20	8,53	5,30	5,07	4,87	4,81	4,74	4,71	4,71	4,68	4,66	4,66
	Ø d 38	J ₁	kgcm ²	16,59	12,78	11,33	10,16	9,48	7,16	6,92	6,72	6,66	6,58	6,55	6,54	6,51	6,50	6,49
	Ø d 42	J ₁	kgcm ²	23,09	19,27	17,82	16,66	15,98	-	-	-	-	-	-	-	-	-	-
	Ø d 48	J ₁	kgcm ²	25,47	21,65	20,20	19,04	18,37	-	-	-	-	-	-	-	-	-	-

▲with reference to output

* measured with 2 % nominal torque on output shaft

**charge centre of output shaft at output speed 250 min⁻¹. Please contact us for combined load applications

MPR(N) 04 - MPR(N) 05

TECHNICAL DATA



MPR				04														
Gear stages				1						2								
Ratio				i	3	4	5	7	10	12	16	20	28	35	50	70	100	
Max. acceleration torque (max. 1000 cycles per hour)				T _{2bzul}	Nm	880	1100	1100	1100	880	1100	1100	1100	1100	1100	1100	880	
Nominal torque on output (with n _{1Nzul})				T _{2Nzul}	Nm	420	550	550	550	340	550	550	550	550	550	550	340	
Emergency stop torque (permissible 1000 times during gearbox life time)				T _{2Notzul}	Nm	2200	2750	2750	2750	2200	2750	2750	2750	2750	2750	2750	2200	
Permissible average input speed (with T _{2Nzul} and 20 °C ambient temperature)				n _{1mzul}	min ⁻¹	1400	1700	1700	2400	2400	2700	2700	2700	2900	2900	2900	3500	3500
Max. input speed				n _{1maxzul}	min ⁻¹	4000						4000						
Max. backlash*				j	arcmin	standard ≤ 6 / reduced ≤ 3						standard ≤ 8 / reduced ≤ 5						
Torsional rigidity [▲]				C	Nm/arcmin	145						125						
Max. radial load** (with reference to shaft centre on output shaft)				F _{2rzul}	N	14000						14000						
Max. axial load** (with reference to shaft centre on output shaft)				F _{2azul}	N	13500						13500						
Weight				m	kg	29						32						
Running noise (with n ₁ = 3000 min ⁻¹ without load)				L _{PA}	dB(A)	≤ 70						≤ 70						
Inertia (with reference to input)	∅ d 28	J ₁	kgcm ²	29,42	22,06	19,46	17,45	16,44	7,15	6,69	5,84	5,15	5,1	4,79	4,77	4,76		
	∅ d 38	J ₁	kgcm ²	29,38	22,02	19,41	17,4	16,39	8,07	7,61	6,76	6,07	6,02	5,71	5,69	5,68		
	∅ d 42	J ₁	kgcm ²	38,71	31,35	28,74	26,73	25,72	-	-	-	-	-	-	-	-		
	∅ d 48	J ₁	kgcm ²	38,36	31	28,39	26,38	25,37	-	-	-	-	-	-	-	-		

MPR				05														
Gear stages				1						2								
Ratio				i	3	4	5	7	10	12	16	20	28	35	50	70	100	
Max. acceleration torque (max. 1000 cycles per hour)				T _{2bzul}	Nm	1500	1900	1900	1900	1500	1900	1900	1900	1900	1900	1900	1500	
Nominal torque on output (with n _{1Nzul})				T _{2Nzul}	Nm	750	1000	1000	1000	620	1000	1000	1000	1000	1000	1000	620	
Emergency stop torque (permissible 1000 times during gearbox life time)				T _{2Notzul}	Nm	3800	4750	4750	4750	3800	4750	4750	4750	4750	4750	4750	3800	
Permissible average input speed (with T _{2Nzul} and 20 °C ambient temperature)				n _{1mzul}	min ⁻¹	1200	1400	1400	2200	2200	2500	2500	2500	2500	2500	2500	3000	3000
Max. input speed				n _{1maxzul}	min ⁻¹	3500						3500						
Max. backlash*				j	arcmin	standard ≤ 6 / reduced ≤ 3						standard ≤ 8 / reduced ≤ 5						
Torsional rigidity [▲]				C	Nm/arcmin	225						195						
Max. radial load** (with reference to shaft centre on output shaft)				F _{2rzul}	N	18000						18000						
Max. axial load** (with reference to shaft centre on output shaft)				F _{2azul}	N	22500						22500						
Weight				m	kg	50						53						
Running noise (with n ₁ = 3000 min ⁻¹ without load)				L _{PA}	dB(A)	≤ 70						≤ 70						
Inertia (with reference to input)	∅ d 28	J ₁	kgcm ²	55,95	35,18	27,5	21,36	18,62	23,42	22,12	19,27	17,35	17,2	16,32	16,26	16,23		
	∅ d 38	J ₁	kgcm ²	55,6	34,83	27,15	21,01	18,27	23,37	22,08	19,22	17,3	17,15	16,27	16,21	16,18		
	∅ d 42	J ₁	kgcm ²	69,37	48,6	40,92	34,78	32,04	32,71	31,41	28,55	26,63	26,48	25,6	25,54	25,51		
	∅ d 48	J ₁	kgcm ²	68,15	47,38	39,7	33,56	30,82	32,35	31,06	28,2	26,28	26,13	25,25	25,19	25,16		
	∅ d 55	J ₁	kgcm ²	66,01	45,24	37,57	31,43	28,69	-	-	-	-	-	-	-	-		

▲with reference to output
* measured with 2 % nominal torque on output shaft
**charge centre of output shaft at output speed 250 min⁻¹. Please contact us for combined load applications

MPR(N) 050 - MPR(N) 300

DIMENSIONS 1-STAGE

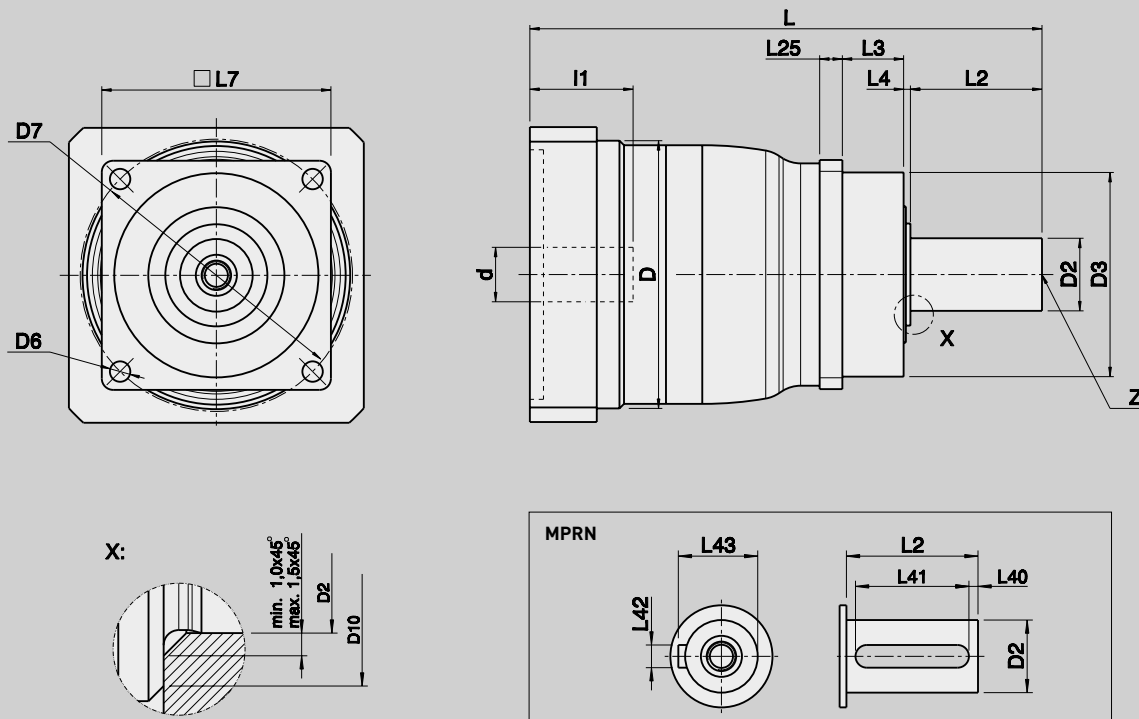

																MPRN = with keyway					
d	x	l1	Size	Ratio	D	D2 x L2	D3	D6	D7	D10	L	L3	L4	L7	L25	Z	L40	L41	L42	L43	
F7						k6	g6									DIN 332			h9		
11 x 23			050	3 - 10	72	16 x 28	60	5,5	68	22	137,0	18,0	2	62	6	D M5	2	25	5	18,0	
14 x 30																					
19 x 40																					146,0
11 x 23			100	3 - 10	94	22 x 36	70	6,6	85	27	168,5	17,5	2,5	76	7	D M8	2	32	6	24,5	
14 x 30																					
19 x 40																					168,5
24 x 50																					178,5
19 x 40																					225,8
24 x 50			200	3 - 10	120	32 x 58	90	9	120	42	225,8	27,0	3	101	10	D M12	4	50	10	35,0	
28 x 60																					225,8
32 x 60																					225,8
38 x 80																					250,8
24 x 50																					295,5
28 x 60			300	3 - 10	154	40 x 82	130	11	165	61	295,5	27,0	3	141	12	D M16	5	70	12	43,0	
32 x 60																					295,5
38 x 80																					295,5
42 x 110																					329,5
48 x 110																					329,5



MPR(N) 050 - MPR(N) 300

DIMENSIONS 2-STAGE

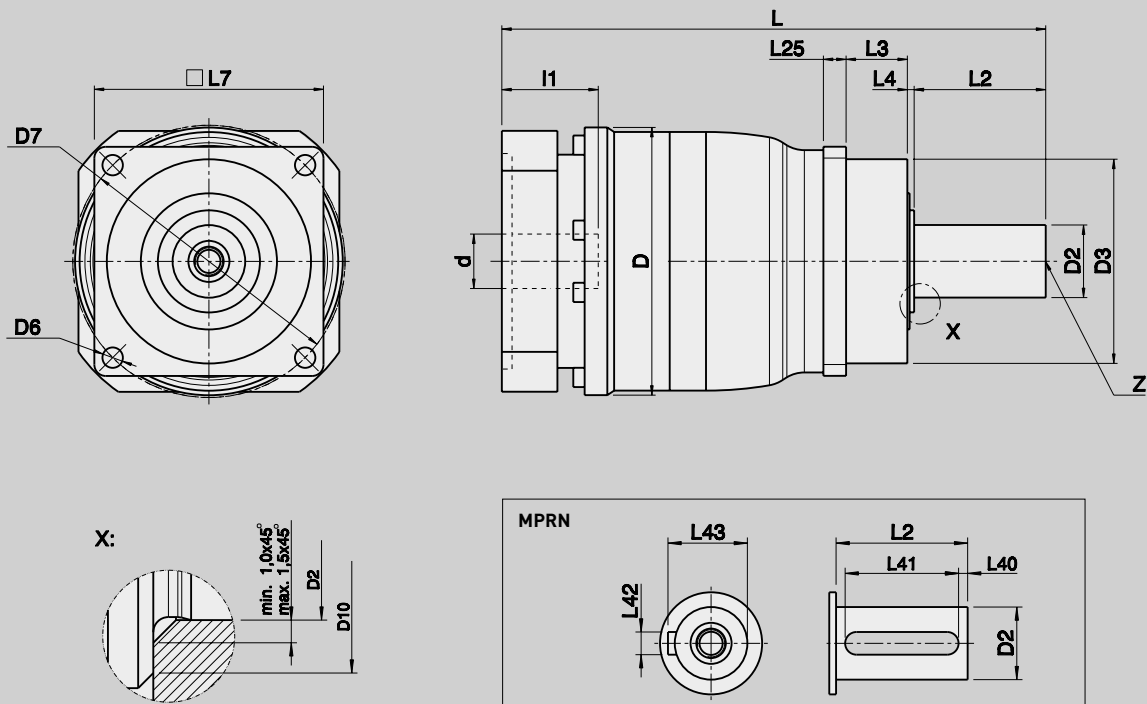

																MPRN = with keyway					
d	x	l1	Size	Ratio	D	D2 x L2	D3	D6	D7	D10	L	L3	L4	L7	L25	Z	L40	L41	L42	L43	
F7						k6	g6									DIN 332			h9		
11	x	23	050	12 - 100	72	16 x 28	60	5,5	68	22	165,5	18,0	2	62	6	D M5	2	25	5	18,0	
14	x	30																			165,5
11	x	23	100	12 - 100	94	22 x 36	70	6,6	85	27	188,5	17,5	2,5	76	7	D M8	2	32	6	24,5	
14	x	30																			188,5
11	x	23	200	12 - 100	120	32 x 58	90	9	120	42	239,8	27,0	3	101	10	D M12	4	50	10	35,0	
14	x	30																			239,8
19	x	40																			239,8
19	x	40																			314,0
24	x	50	300	12 - 100	152	40 x 82	130	11	165	61	314,0	27,0	3	141	12	D M16	5	70	12	43,0	
28	x	60																			314,0
32	x	60																			314,0

MPRW 050 - MPRW 300

DIMENSIONS 1-STAGE

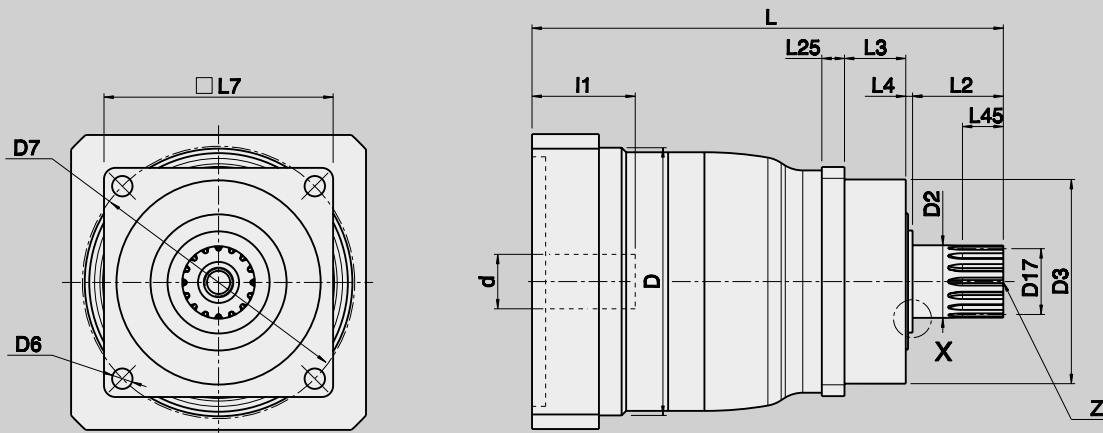

MPRW 050

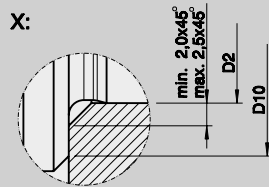

MPRW 100 - 300

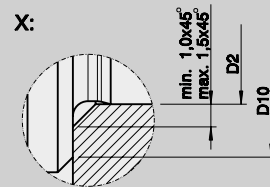

d	x	l1	Size	Ratio	D	D2 x L2	D3	D6	D7	D10	D 17	L	L3	L4	L7	L25	L45	Z
F7						k6	g6				DIN 5480							DIN 332
11 x	23		050	3 - 10	72	16 x 26	60	5,5	68	22	W 16 x 0,8 x 30 x 18 x 6 m	135,0	18,0	2	62	6	15	D M5
14 x	30	135,0																
19 x	40	144,0																
11 x	23		100	3 - 10	94	22 x 26	70	6,6	85	27	W 22 x 1,25 x 30 x 16 x 6 m	158,5	17,5	2,5	76	7	15	D M8
14 x	30	158,5																
19 x	40	158,5																
24 x	50	168,5																
19 x	40	193,8																
24 x	50	193,8	200	3 - 10	120	32 x 26	90	9	120	42	W 32 x 1,25 x 30 x 24 x 6 m	193,8	27,0	3	101	10	15	D M12
28 x	60	193,8																
32 x	60	193,8																
38 x	80	218,8																
24 x	50		300	3 - 10	154	40 x 40	130	11	165	61	W 40 x 2 x 30 x 18 x 6 m	253,5	27,0	3	141	12	20	D M16
28 x	60	253,5																
32 x	60	253,5																
38 x	80	253,5																
42 x	110	287,5																
48 x	110	287,5																



MPRW 050 - MPRW 300

DIMENSIONS 2-STAGE

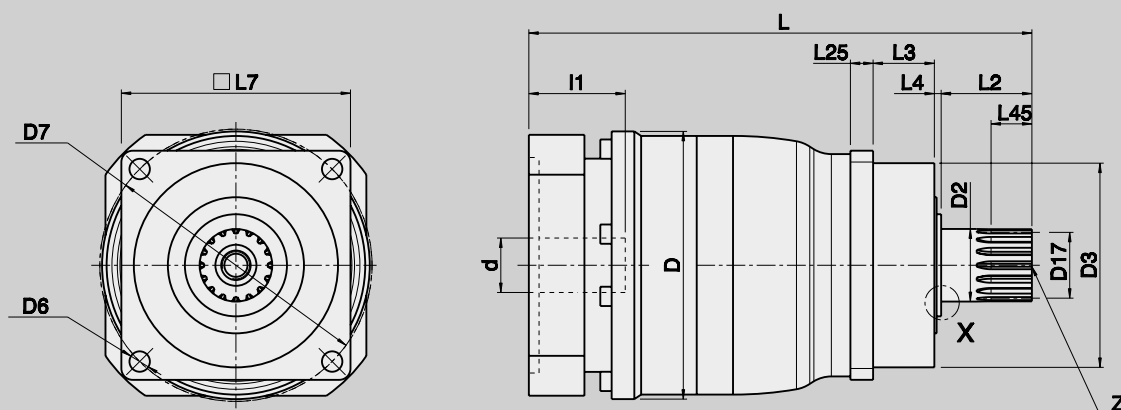

MPRW 050

X:

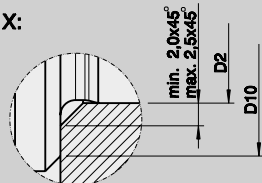

MPRW 100 - 300

X:

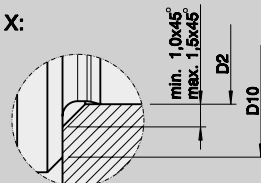

d	x	l1	Size	Ratio	D	D2 x L2	D3	D6	D7	D10	D 17	L	L3	L4	L7	L25	L45	Z
F7						k6	g6				DIN 5480							DIN 332
11	x	23	050	12 - 100	72	16 x 26	60	5,5	68	22	W 16 x 0,8 x 30 x 18 x 6 m	163,5	18,0	2	62	6	15	D M5
14	x	30										163,5						
11	x	23	100	12 - 100	94	22 x 26	70	6,6	85	27	W 22 x 1,25 x 30 x 16 x 6 m	176,5	17,5	2,5	76	7	15	D M8
14	x	30										176,5						
11	x	23	200	12 - 100	120	32 x 26	90	9	120	42	W 32 x 1,25 x 30 x 24 x 6 m	213,8	27,0	3	101	10	15	D M12
14	x	30										213,8						
19	x	40										213,8						
19	x	40	300	12 - 100	152	40 x 40	130	11	165	61	W 40 x 2 x 30 x 18 x 6 m	272,0	27,0	3	141	12	20	D M16
24	x	50										272,0						
28	x	60										272,0						
32	x	60										272,0						

MPR(N) 050 - MPR(N) 300

DIMENSIONS MOTOR MOUNTING 1-STAGE

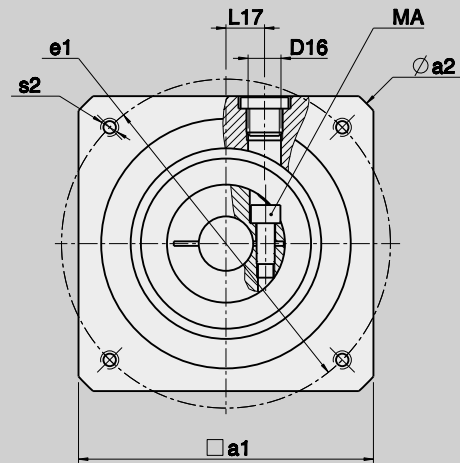
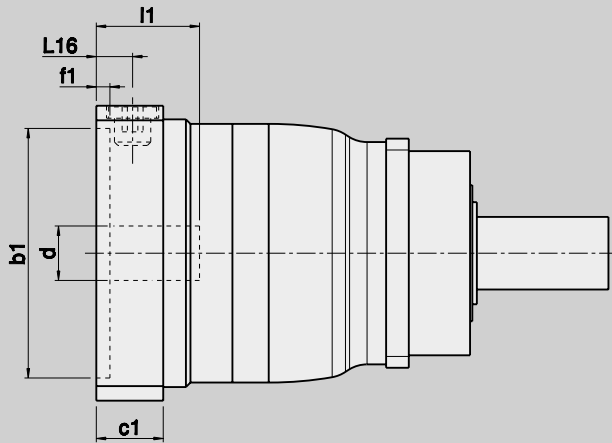

Gearbox dimensions

d	x	l1	Größe	L16	L17	c1	f1	D16	Schraubentyp	MA
F7										
[Nm]										
11	x	23	050	10,5	10	18,5	4,5	M10x1	M5 / 12.9	9
14	x	30		10,5	10 - 12	18,5	4,5	M10x1	M5 / 12.9	9
19	x	40		10,5	12 - 16	18,5	4,5	M10x1	M6 / 12.9	16
11	x	23	100	13,5	10	24,5	4,5	M12x1,5	M5 / 12.9	9
14	x	30		13,5	10 - 12	24,5	4,5	M12x1,5	M5 / 12.9	9
19	x	40		13,5	12 - 16	24,5	4,5	M12x1,5	M6 / 12.9	16
24	x	50		13,5	16 - 21	24,5	4,5	M12x1,5	M8 / 12.9	40
19	x	40	200	16,0	12 - 16	29,5	6,0	M16x1,5	M6 / 12.9	16
24	x	50		16,0	16 - 21	29,5	6,0	M16x1,5	M8 / 12.9	40
28	x	60		16,0	21 - 24	29,5	6,0	M16x1,5	M10 / 12.9	80
32	x	60		16,0	21 - 24	29,5	6,0	M16x1,5	M10 / 12.9	80
38	x	80		16,0	24 - 26	29,5	6,0	M16x1,5	M10 / 12.9	80
24	x	50	300	20,5	16 - 21	36,5	6,0	M20x1,5	M8 / 12.9	40
28	x	60		20,5	21 - 24	36,5	6,0	M20x1,5	M10 / 12.9	80
32	x	60		20,5	21 - 24	36,5	6,0	M20x1,5	M10 / 12.9	80
38	x	80		20,5	24 - 26	36,5	6,0	M20x1,5	M10 / 12.9	80
42	x	110		20,5	26	36,5	6,0	M20x1,5	M12 / 12.9	135
48	x	110		20,5	26	36,5	6,0	M20x1,5	M12 / 12.9	135

MPR(N) 050 - MPR(N) 300

DIMENSIONS MOTOR MOUNTING 2-STAGE

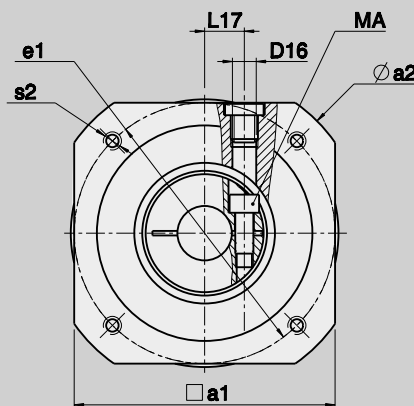
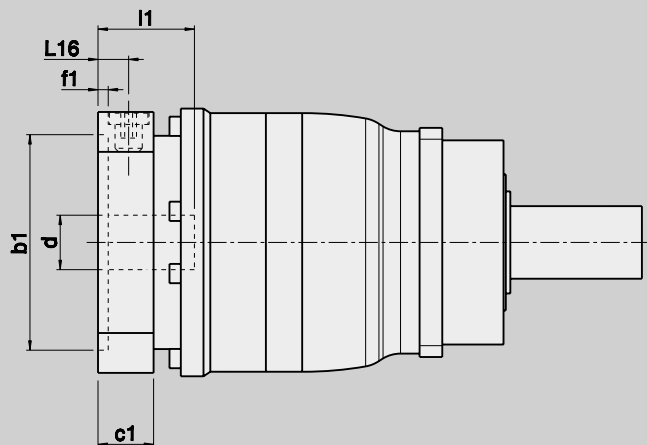

Gearbox dimensions

d	x	l1	Größe	L16	L17	c1	f1	D16	Schraubentyp	MA
F7										
[Nm]										
11	x	23	050	10,5	10	18,5	4,5	M10x1	M5 / 12.9	9
14	x	30		10,5	10 - 12	18,5	4,5	M10x1	M5 / 12.9	9
11	x	23	100	10,5	10	18,5	4,5	M10x1	M5 / 12.9	9
14	x	30		10,5	10 - 12	18,5	4,5	M10x1	M5 / 12.9	9
11	x	23	200	13,5	10	24,5	4,5	M12x1,5	M5 / 12.9	9
14	x	30		13,5	10 - 12	24,5	4,5	M12x1,5	M5 / 12.9	9
19	x	40		13,5	12 - 16	24,5	4,5	M12x1,5	M6 / 12.9	16
19	x	40	300	16,0	12 - 16	29,5	6,0	M16x1,5	M6 / 12.9	16
24	x	50		16,0	16 - 21	29,5	6,0	M16x1,5	M8 / 12.9	40
28	x	60		16,0	21 - 24	29,5	6,0	M16x1,5	M10 / 12.9	80
32	x	60		16,0	16 - 24	29,5	6,0	M16x1,5	M10 / 12.9	80



Motor dimensions

a1		75	75	75	95	95	75	75	95	75	95	95	95	120	115	120	120	130	130	140	160	160	200
a2		90	90	90	120	120	90	90	120	102	120	120	120	140	140	140	160	160	160	190	190	190	250
b1	G8	40	40	50	50	50	60	60	60	60	70	70	80	80	95	95	95	110	110	110	110	130	180
e1		63	63	70	70	95	75	75	75	90	85	90	100	100	115	115	130	130	130	145	165	165	215
s2		M4 x8	M5 x10	M5 x10	M5 x10	M6 x12	M5 x10	M6 x12	M6 x12	M5 x10	M6 x12	M6 x12	M6 x12	M6 x12	M8 x16	M8 x16	M8 x16	M8 x16	M8 x16	M8 x16	M10 x20	M10 x20	M12 x24
		-	-	-	-	-	-	-	-	-	∅ 7,0	-	-	-	-	-	-	∅ 9,0	-	-	-	∅ 11,0	-

	x	x	x			x	x		x													
	x	x	x			x	x		x	x		x		x								
	x	x	x			x	x		x													
	x	x	x			x	x		x	x		x		x								
				x	x			x														
				x	x			x			x	x		x								
													x		x	x		x	x	x		
																		x	x	x	x	x
																					x	x

MPR(N) 04 - MPR(N) 05

DIMENSIONS 1-STAGE

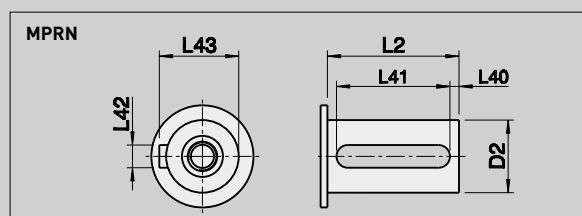
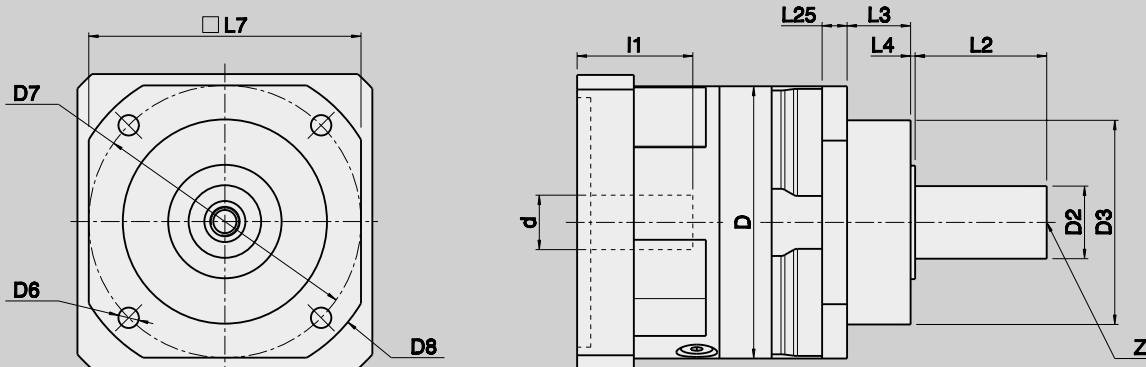

																MPRN = with keyway						
d	x	l1	Size	Ratio	D	D3	D6	D7	D8	L3	L4	L7	L25	D2	x	L2	Z	L40	L41	L42	L43	
F7						g6							k6		DIN 332							
28	x	60	04	3 - 10	185	160	13	215	245	27	3	180	15	55	x	82	D M20	5	70	16	59,0	
32	x	60																				
38	x	80																				
42	x	110																				
48	x	110																				
28	x	60	05	3 - 10	215	180	17	250	280	35	3	215	17	75	x	105	D M20	7	90	20	79,5	
32	x	60																				
38	x	80																				
42	x	110																				
48	x	110																				
55	x	110																				



MPR(N) 04 - MPR(N) 05
DIMENSIONS 2-STAGE

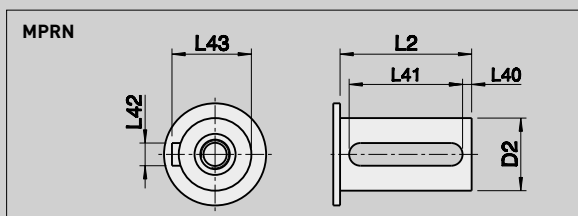
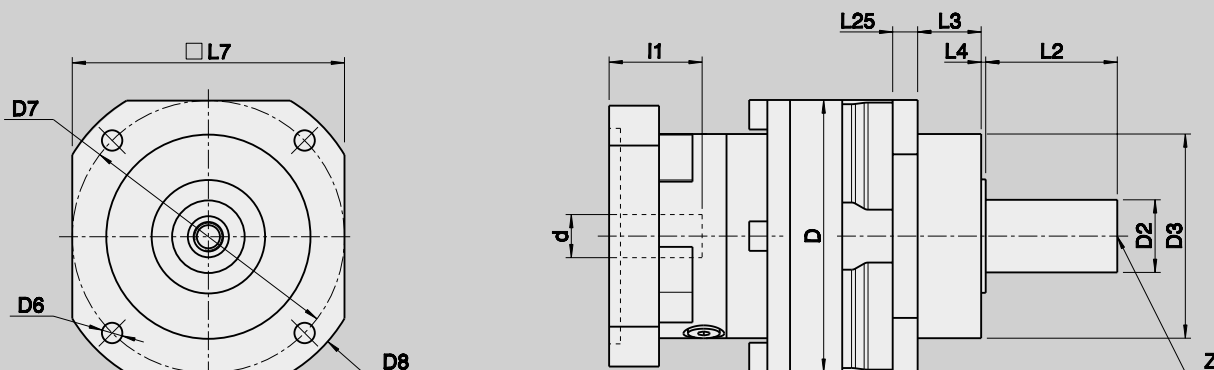

																MPRN = with keyway					
d	x	l1	Size	Ratio	D	D3	D6	D7	D8	L3	L4	L7	L25	D2	x	L2	Z	L40	L41	L42	L43
F7						g6								k6		DIN 332			h9		
28	x	60	04	12 - 100	185	160	13	215	245	27	3	180	15	55	x	82	D M20	5	70	16	59,0
32	x	60																			
38	x	80																			
28	x	60	05	12 - 100	215	180	17	250	280	35	3	215	17	75	x	105	D M20	7	90	20	79,5
32	x	60																			
38	x	80																			
42	x	110																			
48	x	110																			

MPR(N) 04 - MPR(N) 05

DIMENSIONS MOTOR MOUNTING 1-STAGE

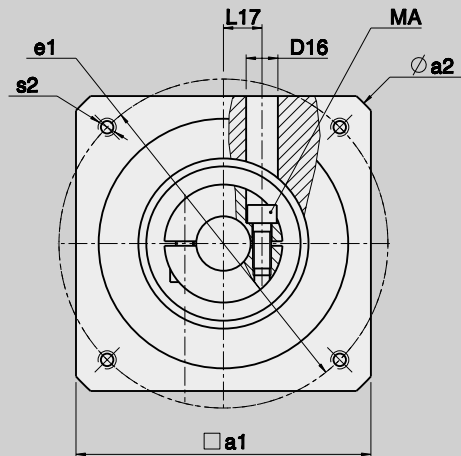
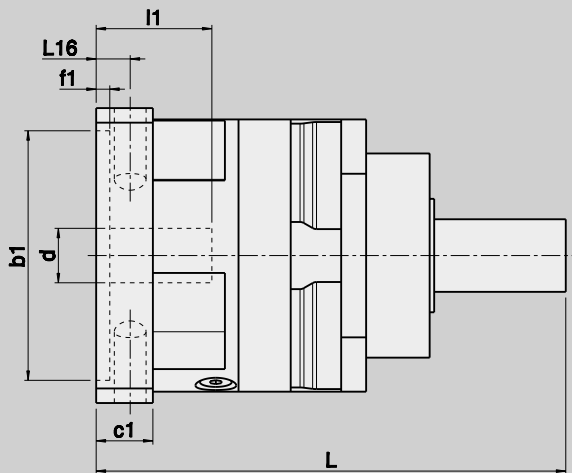

Gearbox dimensions

d	x	l1	Size	L	L16	L17	c1	f1	D16	Screw type	MA
F7											
28	x	60	04	303,5	22,0	23	38,0	6,0	25,0	M10 / 12.9	80
32	x	60		303,5	22,0	23	38,0	6,0	25,0	M10 / 12.9	80
38	x	80		303,5	22,0	23	38,0	6,0	25,0	M10 / 12.9	80
42	x	110		333,5	22,0	23	38,0	6,0	25,0	M12 / 12.9	135
48	x	110		333,5	22,0	23	38,0	6,0	25,0	M12 / 12.9	135
28	x	60	05	355,0	22,0	27	38,0	6,0	25,0	M10 / 12.9	80
32	x	60		355,0	22,0	27	38,0	6,0	25,0	M10 / 12.9	80
38	x	80		355,0	22,0	27	38,0	6,0	25,0	M10 / 12.9	80
42	x	110		385,0	53,0	37	38,0	6,0	25,0	M12 / 12.9	135
48	x	110		385,0	53,0	37	38,0	6,0	25,0	M12 / 12.9	135
55	x	110		385,0	53,0	37	38,0	6,0	25,0	M12 / 12.9	135

Motor dimensions

a1		190	190	200	250	260
a2		220	220	250	300	350
b1	G8	110	130	180	230	250
e1		130	165	215	265	300
s2		M8	M10	M12	M12	M16
		x16	x20	x24	x24	x32
		-	-	Ø 14,0	Ø 14,0	-

x	x	x	x	x
x	x	x	x	x
x	x	x	x	x
x	x	x	x	x
x	x	x	x	x
x	x	x	x	x
x	x	x	x	x
x	x	x	x	x
x	x	x	x	x
x	x	x	x	x



MPR(N) 04 - MPR(N) 05

DIMENSIONS MOTOR MOUNTING 2-STAGE

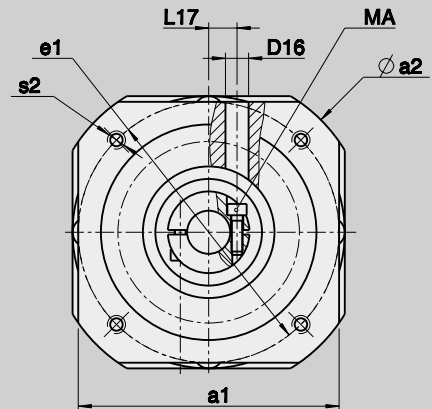
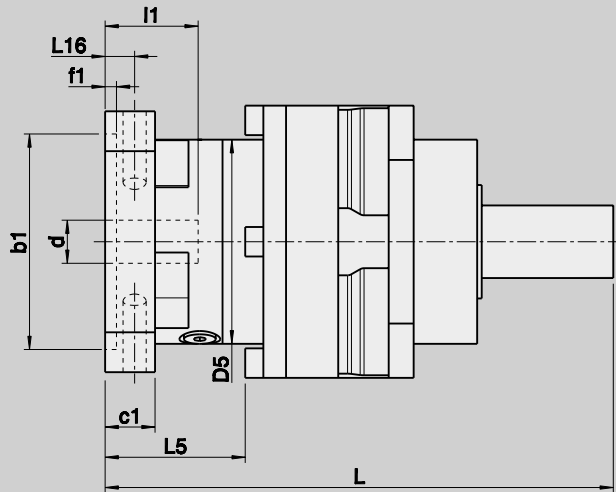

Motor dimensions

a1	160	190	160	190	200	250	260
a2	180	220	190	220	250	300	350
b1	G8	110	110	130	130	180	230
e1		130	130	165	165	215	265
s2		M8	M8	M10	M10	M12	M12
		x16	x16	x20	x20	x24	x24
		∅ 9,0	-	∅ 11,0	-	∅ 14,0	∅ 14,0

Gearbox dimensions

d	x	l1	Size	L	L16	L17	c1	f1	D5	L5	D16	Screw type	MA
F7													[Nm]
28	x	60	04	323,5	18,0	23	30,0	6,0	155	81	17,5	M10 / 12.9	80
32	x	60		323,5	18,0	23	30,0	6,0	155	81	17,5	M10 / 12.9	80
38	x	80		343,5	38,0	23	50,0	6,0	155	101	17,5	M10 / 12.9	80
28	x	60	05	408,0	22,0	27	38,0	6,0	185	118	25,0	M10 / 12.9	80
32	x	60		408,0	22,0	27	38,0	6,0	185	118	25,0	M10 / 12.9	80
38	x	80		408,0	22,0	27	38,0	6,0	185	118	25,0	M10 / 12.9	80
42	x	110		438,0	53,0	37	38,0	6,0	185	148	25,0	M12 / 12.9	135
48	x	110		438,0	53,0	37	38,0	6,0	185	148	25,0	M12 / 12.9	135

x		x		x		
x		x		x		
x		x		x		
	x		x	x	x	x
	x		x	x	x	x
	x		x	x	x	x
	x		x	x	x	x

MPR(N) 04 - MPR(N) 05

MOUNTING POSITION AND LUBRICATION

Note:

The following specifications are valid for gearboxes MPR 04, MPR 05

Mounting position:

(underside)

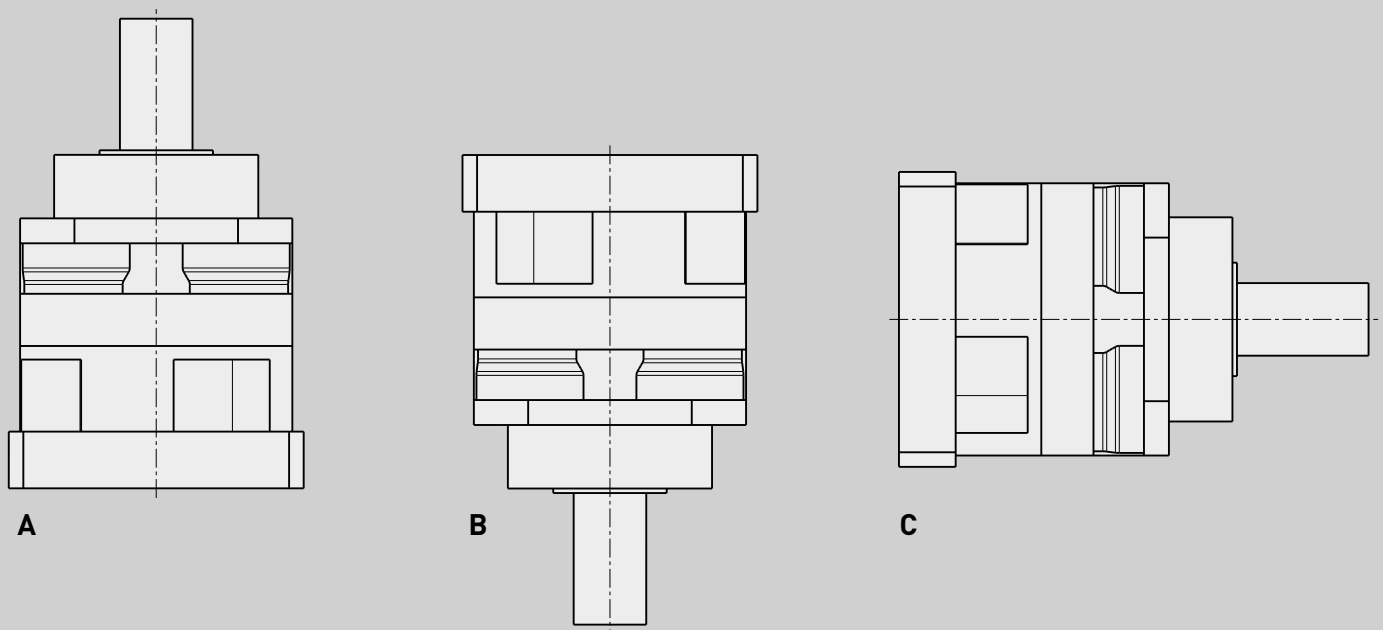

Lubrication

The planetary gearboxes are always oil-lubricated, and are supplied filled with oil. In our factories the gearboxes are filled with a synthetic poly-alpha-olefin-based gear oil. The viscosity is 150 cSt. We supply gearboxes with a quantity of oil suitable for the mounting position given in the order. If it is not clear from the order, gearboxes are supplied with a quantity of oil suitable for the vertical mounting position A.

Subsequent change of mounting position

If it is necessary to change the mounting position later, the oil should always be completely drained from the gearbox for safety reasons. The gearbox must then be refilled with the quantity of oil required for the new mounting position as given in our instructions (see following table).

One of the recommended grades of oil should be used (see following table).



	Oil quantities for mounting position [cm³]					
	A		B		C	
Ratio	3-10	12-100	3-10	12-100	3-10	12-100
MPR 04	550	800	550	800	200	350
MPR 05	800	1400	800	1400	600	850

Recommended oils

Mobil	Optimol
Mobil SHC 629	Optigear Synthetic A 150

Or equivalent oils from other manufacturers.

Caution!

Do not mix mineral and/or synthetic oil grades. This could damage the gearbox.

MPG

TECHNICAL DATA

Technical specifications on this page and in the tables on the following three pages are intended only for rough preselection.

Gear teeth:	MPG 050 - 300 helical gear MPG 04 - 05 spur gear	Lubrication:	lubricated for life
Direction of rotation:	input and output in the same direction	Mounting position:	any, please specify when ordering
Efficiency:	1-stage $\eta \geq 97\%$ 2-stage $\eta \geq 95\%$	Surface protection:	primer coat RAL 9005 black
Life time:	20000 h	Protection rating:	IP65
Permissible gearbox temperature at housing:	-10 °C to +90 °C		





MPG 050 - MPG 100

TECHNICAL DATA

The following technical specifications in the table are intended only for rough preselection

MPG				050																
Gear stages				1				2												
Ratio				i	4	5	7	10	16	20	25	28	35	40	50	70	100			
Max. acceleration torque (max. 1000 cycles per hour)				T _{2bzul}	Nm	44	44	44	35	44	44	44	44	44	44	44	35			
Nominal torque on output (with n _{1Nzul})				T _{2Nzul}	Nm	29	29	29	19	29	29	29	29	29	29	29	19			
Emergency stop torque (permissible 1000 times during gearbox life time)				T _{2Notzul}	Nm	110	110	107	88	110	110	110	110	110	110	107	88			
Permissible average input speed (with T _{2Nzul} and 20 °C ambient temperature)				n _{1mzul}	min ⁻¹	3300	3300	3700	4000	4400	4400	4400	4400	4400	4800	5500	5500			
Max. input speed				n _{1maxzul}	min ⁻¹	6000				6000										
Max. backlash*				j	arcmin	standard ≤ 4 / reduced ≤ 2				standard ≤ 4 / reduced ≤ 2										
Torsional rigidity [▲]				C	Nm/arcmin	-				-										
Max. axial load** (with reference to shaft centre on output shaft)				F _{2azul}	N	2200				2200										
Weight				m	kg	1,5				2,1										
Running noise (with n ₁ = 3000 min ⁻¹ without load)				L _{PA}	dB(A)	≤ 64				≤ 64										
Inertia (with reference to input)				Ø d 11	J ₁	kgcm ²	0,24	0,20	0,18	0,16	0,21	0,18	0,18	0,17	0,17	0,16	0,16	0,16	0,16	
				Ø d 14	J ₁	kgcm ²	0,27	0,23	0,21	0,19	0,24	0,21	0,21	0,20	0,20	0,19	0,19	0,19	0,19	0,19
				Ø d 19	J ₁	kgcm ²	0,44	0,40	0,34	0,33	-	-	-	-	-	-	-	-	-	-

MPG				100																
Gear stages				1				2												
Ratio				i	4	5	7	10	16	20	25	28	35	40	50	70	100			
Max. acceleration torque (max. 1000 cycles per hour)				T _{2bzul}	Nm	120	120	120	90	120	120	120	120	120	120	120	90			
Nominal torque on output (with n _{1Nzul})				T _{2Nzul}	Nm	83	83	83	58	83	83	83	83	83	76	83	58			
Emergency stop torque (permissible 1000 times during gearbox life time)				T _{2Notzul}	Nm	275	275	275	220	275	275	275	275	275	275	275	220			
Permissible average input speed (with T _{2Nzul} and 20 °C ambient temperature)				n _{1mzul}	min ⁻¹	2800	2800	2800	3100	3500	3500	3500	3500	3500	3500	3800	4500	4500		
Max. input speed				n _{1maxzul}	min ⁻¹	6000				6000										
Max. backlash*				j	arcmin	standard ≤ 3 / reduced ≤ 1				standard ≤ 3 / reduced ≤ 1										
Torsional rigidity [▲]				C	Nm/arcmin	-				-										
Max. axial load** (with reference to shaft centre on output shaft)				F _{2azul}	N	3600				3600										
Weight				m	kg	3,9				4,3										
Running noise (with n ₁ = 3000 min ⁻¹ without load)				L _{PA}	dB(A)	≤ 64				≤ 64										
Inertia (with reference to input)				Ø d 11	J ₁	kgcm ²	0,86	0,68	0,54	0,46	0,24	0,20	0,19	0,17	0,17	0,16	0,16	0,16	0,16	
				Ø d 14	J ₁	kgcm ²	0,90	0,72	0,57	0,50	0,27	0,23	0,22	0,21	0,20	0,19	0,19	0,19	0,19	0,19
				Ø d 19	J ₁	kgcm ²	1,04	0,87	0,72	0,64	-	-	-	-	-	-	-	-	-	-
				Ø d 24	J ₁	kgcm ²	1,75	1,57	1,42	1,35	-	-	-	-	-	-	-	-	-	-

▲with reference to output

* measured with 2 % nominal torque on output shaft

**charge centre of output shaft at output speed 250 min⁻¹. Please contact us for combined load applications

MPG 200 - MPG 300

TECHNICAL DATA

MPG				200														
Gear stages				1				2										
Ratio				i	4	5	7	10	16	20	25	28	35	40	50	70	100	
Max. acceleration torque (max. 1000 cycles per hour)				T _{2bzul}	Nm	330	330	300	235	330	330	330	330	330	330	330	235	
Nominal torque on output (with n _{1Nzul})				T _{2Nzul}	Nm	200	195	190	135	200	195	195	200	195	200	195	135	
Emergency stop torque (permissible 1000 times during gearbox life time)				T _{2Notzul}	Nm	690	675	640	550	690	675	675	690	675	690	675	550	
Permissible average input speed (with T _{2Nzul} and 20 °C ambient temperature)				n _{1mzul}	min ⁻¹	2500	2500	2800	2800	3100	3100	3100	3100	3100	3100	3500	4200	4200
Max. input speed				n _{1maxzul}	min ⁻¹	4500				4500								
Max. backlash*				j	arcmin	standard ≤ 3 / reduced ≤ 1				standard ≤ 3 / reduced ≤ 1								
Torsional rigidity [▲]				C	Nm/arcmin	-				-								
Max. axial load** (with reference to shaft centre on output shaft)				F _{2azul}	N	4200				4200								
Weight				m	kg	6,6				7,0								
Running noise (with n ₁ = 3000 min ⁻¹ without load)				L _{PA}	dB(A)	≤ 66				≤ 64								
Inertia (with reference to input)	Ø d 11	J ₁	kgcm ²	-	-	-	-	0,74	0,59	0,57	0,49	0,48	0,44	0,43	0,43	0,42		
	Ø d 14	J ₁	kgcm ²	-	-	-	-	0,78	0,62	0,60	0,52	0,51	0,47	0,47	0,46	0,46		
	Ø d 19	J ₁	kgcm ²	3,48	2,94	2,50	2,27	0,92	0,77	0,75	0,67	0,66	0,62	0,61	0,61	0,60		
	Ø d 24	J ₁	kgcm ²	4,00	3,46	3,02	2,79	-	-	-	-	-	-	-	-	-		
	Ø d 28	J ₁	kgcm ²	5,81	5,27	4,82	4,59	-	-	-	-	-	-	-	-	-		
	Ø d 32	J ₁	kgcm ²	6,09	5,55	5,10	4,87	-	-	-	-	-	-	-	-	-		
	Ø d 38	J ₁	kgcm ²	7,94	7,40	6,94	6,71	-	-	-	-	-	-	-	-	-		

MPG				300														
Gear stages				1				2										
Ratio				i	4	5	7	10	16	20	25	28	35	40	50	70	100	
Max. acceleration torque (max. 1000 cycles per hour)				T _{2bzul}	Nm	660	660	600	480	660	660	660	660	660	660	660	480	
Nominal torque on output (with n _{1Nzul})				T _{2Nzul}	Nm	390	390	380	245	390	390	390	390	390	390	380	245	
Emergency stop torque (permissible 1000 times during gearbox life time)				T _{2Notzul}	Nm	1400	1400	1400	1100	1400	1400	1400	1400	1400	1400	1400	1100	
Permissible average input speed (with T _{2Nzul} and 20 °C ambient temperature)				n _{1mzul}	min ⁻¹	2100	2100	2300	2600	2900	2900	2900	2900	2900	2900	3200	3200	3900
Max. input speed				n _{1maxzul}	min ⁻¹	4000				4000								
Max. backlash*				j	arcmin	standard ≤ 3 / reduced ≤ 1				standard ≤ 3 / reduced ≤ 1								
Torsional rigidity [▲]				C	Nm/arcmin	-				-								
Max. axial load** (with reference to shaft centre on output shaft)				F _{2azul}	N	8000				8000								
Weight				m	kg	13,5				14,4								
Running noise (with n ₁ = 3000 min ⁻¹ without load)				L _{PA}	dB(A)	≤ 66				≤ 65								
Inertia (with reference to input)	Ø d 19	J ₁	kgcm ²	-	-	-	-	3,19	2,75	2,68	2,41	2,37	2,23	2,21	2,19	2,19		
	Ø d 24	J ₁	kgcm ²	10,81	8,98	7,50	6,70	3,71	3,28	3,20	2,93	2,89	2,74	2,72	2,71	2,70		
	Ø d 28	J ₁	kgcm ²	12,58	10,75	9,26	8,46	5,52	5,08	5,01	4,72	4,69	4,54	4,52	4,51	4,50		
	Ø d 32	J ₁	kgcm ²	12,89	11,06	9,57	8,77	5,80	5,36	5,29	5,01	4,97	4,83	4,81	4,79	4,78		
	Ø d 38	J ₁	kgcm ²	13,87	12,04	10,52	9,72	7,65	7,22	7,14	6,84	6,81	6,66	6,64	6,63	6,62		
	Ø d 42	J ₁	kgcm ²	20,36	18,53	17,02	16,22	-	-	-	-	-	-	-	-	-		
	Ø d 48	J ₁	kgcm ²	22,75	20,92	19,41	18,61	-	-	-	-	-	-	-	-	-		

[▲]with reference to output

* measured with 2 % nominal torque on output shaft

**charge centre of output shaft at output speed 250 min⁻¹. Please contact us for combined load applications



MPG 04 - MPG 05

TECHNICAL DATA

MPG				04													
Gear stages				1				2									
Ratio				i	4	5	7	10	12	16	20	28	35	50	70	100	
Max. acceleration torque (max. 1000 cycles per hour)				T _{2bzul}	Nm	1100	1100	1100	880	1100	1100	1100	1100	1100	1100	880	
Nominal torque on output (with n _{1Nzul})				T _{2Nzul}	Nm	550	550	550	340	550	550	550	550	550	550	340	
Emergency stop torque (permissible 1000 times during gearbox life time)				T _{2Notzul}	Nm	2750	2750	2750	2200	2750	2750	2750	2750	2750	2750	2200	
Permissible average input speed (with T _{2Nzul} and 20 °C ambient temperature)				n _{1mzul}	min ⁻¹	1700	1700	2400	2400	2700	2700	2700	2900	2900	2900	3500	3500
Max. input speed				n _{1maxzul}	min ⁻¹	4000				4000							
Max. backlash*				j	arcmin	standard ≤ 6 / reduced ≤ 3				standard ≤ 8 / reduced ≤ 5							
Torsional rigidity [▲]				C	Nm/arcmin	145				125							
Max. radial load** (with reference to shaft centre on output shaft)				F _{2rzul}	N	18070				18070							
Max. axial load** (with reference to shaft centre on output shaft)				F _{2azul}	N	9100				9100							
Weight				m	kg	21				24							
Running noise (with n ₁ = 3000 min ⁻¹ without load)				L _{PA}	dB(A)	≤ 70				≤ 70							
Inertia (with reference to input)	Ø d 28	J ₁	kgcm ²	25,33	21,52	18,51	17,09	9,45	6,90	5,97	5,22	5,14	4,81	4,78	4,77		
	Ø d 38	J ₁	kgcm ²	25,28	21,48	18,46	17,03	10,36	7,81	6,89	6,14	6,06	5,74	5,71	5,69		
	Ø d 42	J ₁	kgcm ²	34,61	30,81	27,79	26,37	-	-	-	-	-	-	-	-		
	Ø d 48	J ₁	kgcm ²	34,36	30,46	27,44	26,01	-	-	-	-	-	-	-	-		

MPG				05													
Gear stages				1				2									
Ratio				i	4	5	7	10	12	16	20	28	35	50	70	100	
Max. acceleration torque (max. 1000 cycles per hour)				T _{2bzul}	Nm	1900	1900	1900	1500	1900	1900	1900	1900	1900	1900	1500	
Nominal torque on output (with n _{1Nzul})				T _{2Nzul}	Nm	1000	1000	1000	620	1000	1000	1000	1000	1000	1000	620	
Emergency stop torque (permissible 1000 times during gearbox life time)				T _{2Notzul}	Nm	4750	4750	4750	3800	4750	4750	4750	4750	4750	4750	3800	
Permissible average input speed (with T _{2Nzul} and 20 °C ambient temperature)				n _{1mzul}	min ⁻¹	1400	1400	2200	2200	2500	2500	2500	2500	2500	3000	3000	
Max. input speed				n _{1maxzul}	min ⁻¹	3500				3500							
Max. backlash*				j	arcmin	standard ≤ 6 / reduced ≤ 3				standard ≤ 8 / reduced ≤ 5							
Torsional rigidity [▲]				C	Nm/arcmin	225				195							
Max. radial load** (with reference to shaft centre on output shaft)				F _{2rzul}	N	19550				19550							
Max. axial load** (with reference to shaft centre on output shaft)				F _{2azul}	N	10050				10050							
Weight				m	kg	38				40							
Running noise (with n ₁ = 3000 min ⁻¹ without load)				L _{PA}	dB(A)	≤ 70				≤ 70							
Inertia (with reference to input)	Ø d 28	J ₁	kgcm ²	39,34	29,70	22,49	19,18	29,34	22,38	19,44	17,44	17,24	16,34	16,27	16,24		
	Ø d 38	J ₁	kgcm ²	38,99	29,35	22,14	18,83	29,29	22,34	19,39	17,39	17,19	16,29	16,22	16,19		
	Ø d 42	J ₁	kgcm ²	52,76	43,12	35,91	32,60	38,62	31,67	28,72	26,72	26,52	25,62	25,55	25,52		
	Ø d 48	J ₁	kgcm ²	51,54	41,90	34,69	31,38	38,27	31,32	28,37	26,37	26,17	25,27	25,20	25,17		
	Ø d 55	J ₁	kgcm ²	49,40	39,76	32,55	29,24	-	-	-	-	-	-	-	-		

▲with reference to output
 * measured with 2 % nominal torque on output shaft
 **charge centre of output shaft at output speed 250 min⁻¹. Please contact us for combined load applications

MPG 050 - MPG 300
DIMENSIONS 1-STAGE

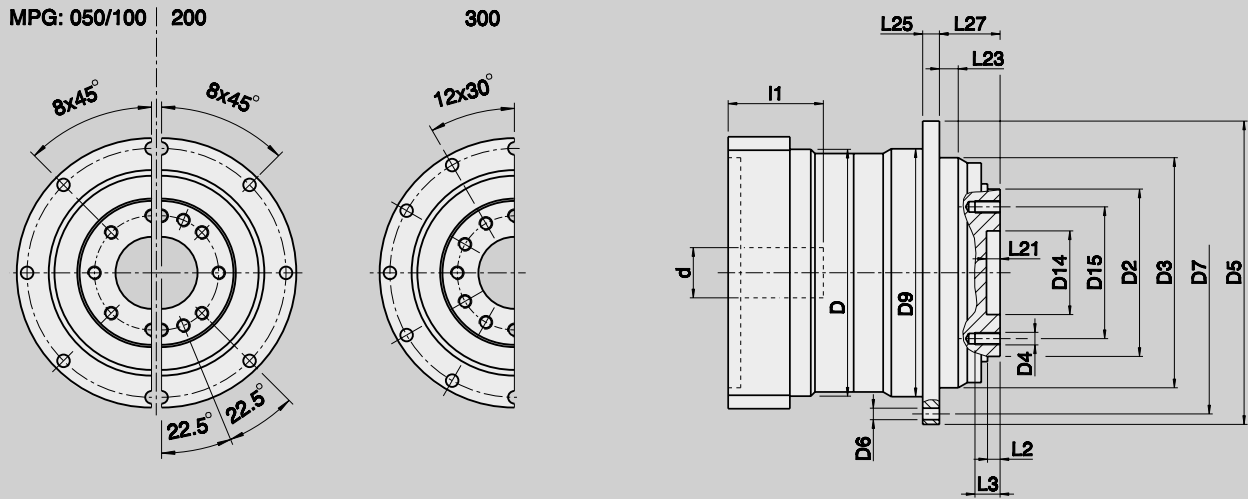

d	x	l1	Size	Ratio	D	D2	x	L2	D3	D4	x	L3	D5	D6	D7	D9	D14	D15	L21	L23	L25	L27
F7						h7			h7								H7					
11	x	23	050	4 - 10	72	40	x	3,0	64	M5	x	7	86	4,5	79	70,5	20,0	31,5	4,0	8,0	4	19,5
14	x	30																				
19	x	40																				
11	x	23	100	4 - 10	94	63	x	6,0	90	M6	x	10	118	5,5	109	95,5	31,5	50,0	7,0	11,0	7	30,0
14	x	30																				
19	x	40																				
24	x	50																				
19	x	40	200	4 - 10	120	80	x	6,5	110	M6	x	12	145	5,5	135	120,5	40,0	63,0	6,5	10,0	8	29,0
24	x	50																				
28	x	60																				
32	x	60																				
38	x	80																				
24	x	50	300	4 - 10	154	100	x	6,5	140	M8	x	16	179	6,6	168	152,5	50,0	80,0	6,5	14,5	10	38,0
28	x	60																				
32	x	60																				
38	x	80																				
42	x	110																				
48	x	110																				



MPG 050 - MPG 300

DIMENSIONS 2-STAGE

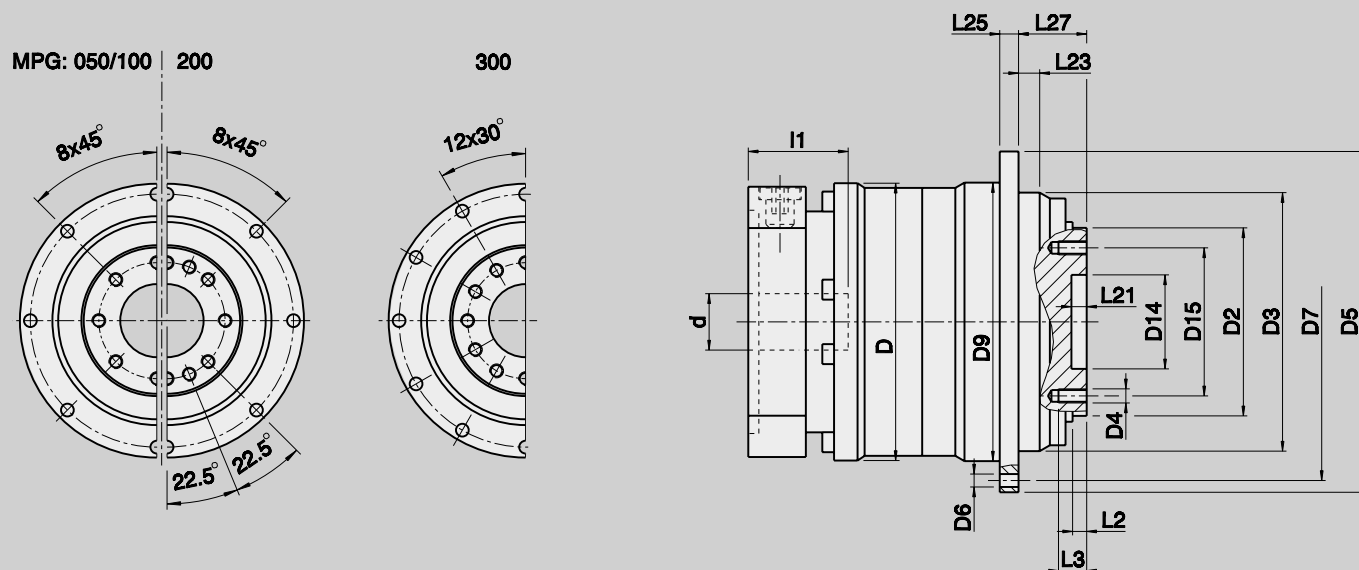

d	x	l1	Size	Ratio	D	D2	x	L2	D3	D4	x	L3	D5	D6	D7	D9	D14	D15	L21	L23	L25	L27															
F7						h7			h7								H7																				
11	x	23	050	16 - 100	72	40	x	3,0	64	M5	x	7	86	4,5	79	70,5	20,0	31,5	4,0	8,0	4	19,5															
14	x	30																																			
11	x	23	100	16 - 100	94	63	x	6,0	90	M6	x	10	118	5,5	109	95,5	31,5	50,0	7,0	11,0	7	30,0															
14	x	30																																			
11	x	23	200	16 - 100	120	80	x	6,5	110	M6	x	12	145	5,5	135	120,5	40,0	63,0	6,5	10,0	8	29,0															
14	x	30																																			
19	x	40	300	16 - 100	154	100	x	6,5	140	M8	x	16	179	6,6	168	152,5	50,0	80,0	6,5	14,5	10	38,0															
19	x	40																																			
24	x	50																																			
28	x	60																																			
32	x	60																																			

MPG 050 - MPG 300

DIMENSIONS MOTOR MOUNTING 1-STAGE

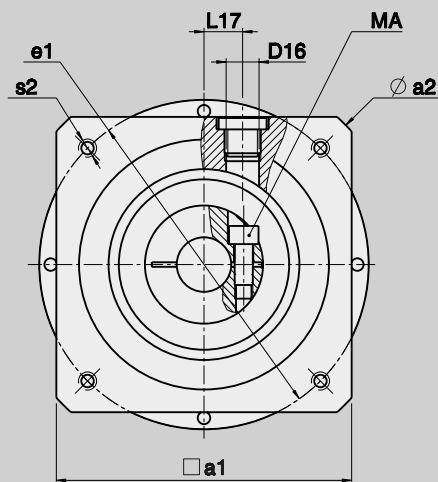
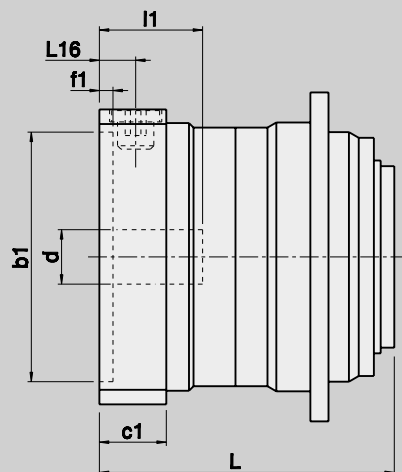

Gearbox dimensions

d	x	l1	Size	L	L16	L17	c1	f1	D16	Screw type	MA
F7											
											[Nm]
11	x	23	050	80,0	10,5	10	18,5	4,5	M10x1	M5 / 12.9	9
14	x	30		80,0	10,5	10 - 12	18,5	4,5	M10x1	M5 / 12.9	9
19	x	40		89,0	10,5	12 - 16	18,5	4,5	M10x1	M6 / 12.9	16
11	x	23	100	101,5	13,5	10	24,5	4,5	M12x1,5	M5 / 12.9	9
14	x	30		101,5	13,5	10 - 12	24,5	4,5	M12x1,5	M5 / 12.9	9
19	x	40		101,5	13,5	12 - 16	24,5	4,5	M12x1,5	M6 / 12.9	16
24	x	50		111,5	13,5	16 - 21	24,5	4,5	M12x1,5	M8 / 12.9	40
19	x	40	200	130,0	16,0	12 - 16	29,5	6,0	M16x1,5	M6 / 12.9	16
24	x	50		130,0	16,0	16 - 21	29,5	6,0	M16x1,5	M8 / 12.9	40
28	x	60		130,0	16,0	21 - 24	29,5	6,0	M16x1,5	M10 / 12.9	80
32	x	60		130,0	16,0	21 - 24	29,5	6,0	M16x1,5	M10 / 12.9	80
38	x	80		155,0	16,0	24 - 26	29,5	6,0	M16x1,5	M10 / 12.9	80
24	x	50	300	165,0	20,5	16 - 21	36,5	6,0	M20x1,5	M8 / 12.9	40
28	x	60		165,0	20,5	21 - 24	36,5	6,0	M20x1,5	M10 / 12.9	80
32	x	60		165,0	20,5	21 - 24	36,5	6,0	M20x1,5	M10 / 12.9	80
38	x	80		165,0	20,5	24 - 26	36,5	6,0	M20x1,5	M10 / 12.9	80
42	x	110		199,0	20,5	26	36,5	6,0	M20x1,5	M12 / 12.9	135
48	x	110		199,0	20,5	26	36,5	6,0	M20x1,5	M12 / 12.9	135



Motor dimensions

a1		75	75	75	95	95	75	75	95	75	95	95	95	120	115	120	120	130	130	150	140	150	160	150	160	200	250
a2		90	90	90	120	120	90	90	120	102	120	120	120	140	140	140	160	160	160	186	190	186	190	186	190	250	300
b1	G8	40	40	50	50	50	60	60	60	60	70	70	80	80	95	95	95	110	110	110	110	110	110	130	130	180	230
e1		63	63	70	70	95	75	75	75	90	85	90	100	100	115	115	130	130	130	130	145	145	165	165	165	215	265
s2		M4 x8	M5 x10	M5 x10	M5 x10	M6 x12	M5 x10	M6 x12	M6 x12	M5 x10	M6 x12	M6 x12	M6 x12	M6 x12	M8 x16	M8 x16	M8 x16	M8 x16	M8 x16	M8 x16	M8 x16	M8 x16	M10 x20	M10 x20	M10 x20	M12 x24	M12 x24
		-	-	-	-	-	-	-	-	-	∅ 7,0	-	-	-	-	-	-	-	∅ 9,0	-	-	-	-	-	-	∅ 11,0	-

x	x	x			x	x		x	x																				
x	x	x			x	x		x	x			x		x				x											
			x	x			x				x	x		x				x											
														x		x	x		x		x					x			
																			x			x					x		
																										x			
																											x		

MPG 050 - MPG 300

DIMENSIONS MOTOR MOUNTING 2-STAGE

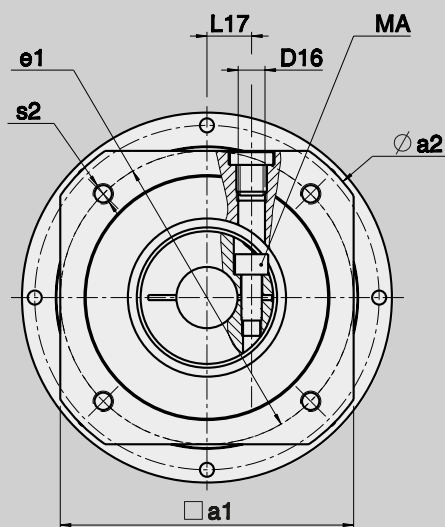
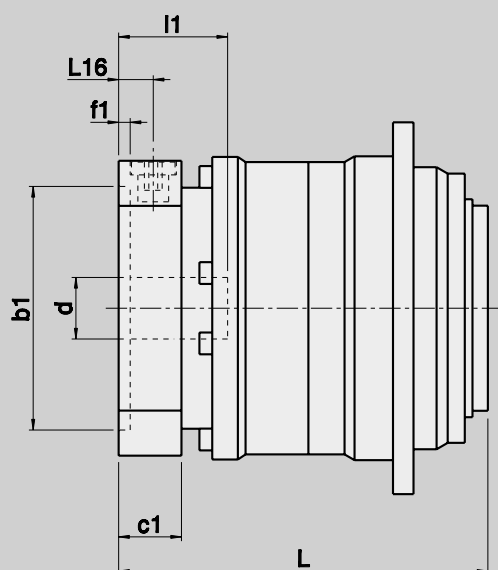

Gearbox dimensions

d	x	l1	Size	L	L16	L17	c1	f1	D16	Screw type	MA
F7											
11	x	23	050	108,5	10,5	10	18,5	4,5	M10x1	M5 / 12.9	9
14	x	30		108,5	10,5	10 - 12	18,5	4,5	M10x1	M5 / 12.9	9
11	x	23	100	121,5	10,5	10	18,5	4,5	M10x1	M5 / 12.9	9
14	x	30		121,5	10,5	10 - 12	18,5	4,5	M10x1	M5 / 12.9	9
11	x	23	200	144,0	13,5	10	24,5	4,5	M12x1,5	M5 / 12.9	9
14	x	30		144,0	13,5	10 - 12	24,5	4,5	M12x1,5	M5 / 12.9	9
19	x	40		144,0	13,5	12 - 16	24,5	4,5	M12x1,5	M6 / 12.9	16
19	x	40	300	183,5	16,0	12 - 16	29,5	6,0	M16x1,5	M6 / 12.9	16
24	x	50		183,5	16,0	16 - 21	29,5	6,0	M16x1,5	M8 / 12.9	40
28	x	60		183,5	16,0	21 - 24	29,5	6,0	M16x1,5	M10 / 12.9	80
32	x	60		183,5	16,0	16 - 24	29,5	6,0	M16x1,5	M10 / 12.9	80



Motor dimensions

a1		75	75	75	95	95	75	75	95	75	95	95	95	120	115	120	120	130	130	140	160	160	200
a2		90	90	90	120	120	90	90	120	102	120	120	120	140	140	140	160	160	160	190	190	190	250
b1	G8	40	40	50	50	50	60	60	60	60	70	70	80	80	95	95	95	110	110	110	110	130	180
e1		63	63	70	70	95	75	75	75	90	85	90	100	100	115	115	130	130	130	145	165	165	215
s2		M4 x8	M5 x10	M5 x10	M5 x10	M6 x12	M5 x10	M6 x12	M6 x12	M5 x10	M6 x12	M6 x12	M6 x12	M6 x12	M8 x16	M8 x16	M8 x16	M8 x16	M8 x16	M8 x16	M10 x20	M10 x20	M12 x24
		-	-	-	-	-	-	-	-	-	∅ 7,0	-	-	-	-	-	-	-	-	-	-	∅ 9,0	-

x	x	x			x	x		x																
x	x	x			x	x		x	x			x			x									
x	x	x			x	x		x	x			x			x									
			x	x				x																
			x	x				x																
													x		x	x			x	x	x			
																			x	x	x	x		
																						x	x	
																						x	x	

MPG 04 - MPG 05

DIMENSIONS 1-STAGE

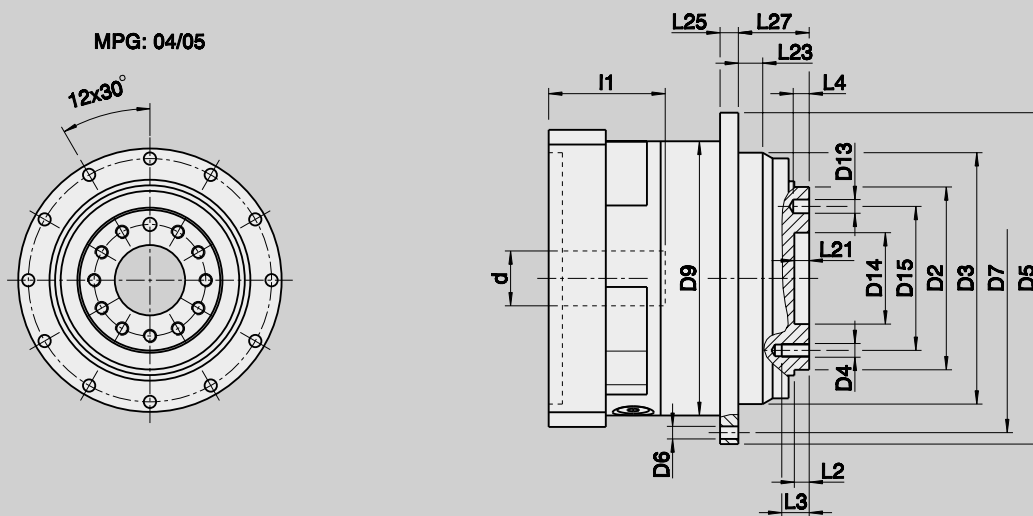

d	x	l1	Size	Ratio	D2	x	L2	D3	D4	D5	D6	D7	D9	D13	D14	D15	L3	L4	L21	L23	L25	L27
F7					h7		h7						h7	H7	H7							
28	x	60	04	4 - 10	130	x	7,0	170	M10	215	8,5	200	185	10	65,0	100,0	20	10	8,0	12	12	45,0
32	x	60																				
38	x	80																				
42	x	110																				
48	x	110																				
28	x	60	05	4 - 10	160	x	8,0	200	M10	247	8,5	233	215	10	80,0	125,0	20	10	8,0	15	12	50,0
32	x	60																				
38	x	80																				
42	x	110																				
48	x	110																				
55	x	110																				



MPG 04 - MPG 05

DIMENSIONS 2-STAGE

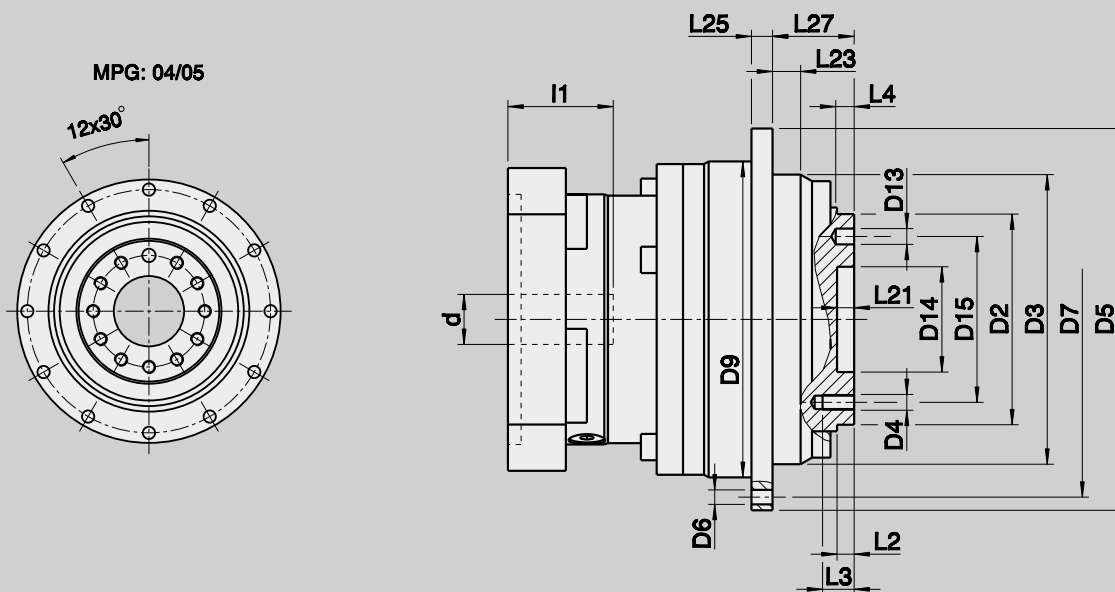

d	x	l1	Size	Ratio	D2	x	L2	D3	D4	D5	D6	D7	D9	D13	D14	D15	L3	L4	L21	L23	L25	L27	
F7					h7			h7					h7	H7	H7								
28	x	60	04	12 - 100	130	x	7,0	170	M10	215	8,5	200	185	10	65,0	100,0	20	10	8,0	12	12	45,0	
32	x	60																					
38	x	80																					
28	x	60	05	12 - 100	160	x	8,0	200	M10	247	8,5	233	215	10	80,0	125,0	20	10	8,0	15	12	50,0	
32	x	60																					
38	x	80																					
42	x	110																					
48	x	110																					

M P G 0 4 - M P G 0 5

D I M E N S I O N S M O T O R M O U N T I N G 1 - S T A G E

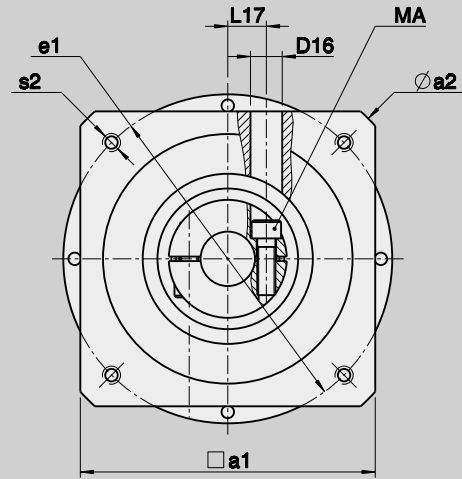
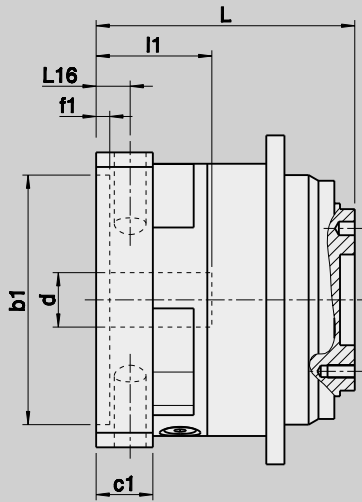

Motor dimensions						
a1		190	190	200	250	260
a2		220	220	250	300	350
b1	G8	110	130	180	230	250
e1		130	165	215	265	300
s2		M8 x16	M10 x20	M12 x24	M12 x24	M16 x32
		-	-	∅ 13,0	∅ 13,0	-

Gearbox dimensions											
d	x	l1	Size	L	L16	L17	c1	f1	D16	Screw type	MA
F7											
											[Nm]
28	x	60	04	182,0	22,0	35	38	6,0	25,0	M12 / 12.9	135
32	x	60		182,0	22,0	35	38	6,0	25,0	M12 / 12.9	135
38	x	80		182,0	22,0	35	38	6,0	25,0	M12 / 12.9	135
42	x	110		212,0	22,0	35	38	6,0	25,0	M12 / 12.9	135
48	x	110		212,0	22,0	35	38	6,0	25,0	M12 / 12.9	135
28	x	60	05	195,0	22,0	27	38	6,0	25,0	M10 / 12.9	80
32	x	60		195,0	22,0	27	38	6,0	25,0	M10 / 12.9	80
38	x	80		195,0	22,0	27	38	6,0	25,0	M10 / 12.9	80
42	x	110		225,0	53,0	37	38	6,0	25,0	M12 / 12.9	135
48	x	110		225,0	53,0	37	38	6,0	25,0	M12 / 12.9	135
55	x	110		225,0	53,0	37	38	6,0	25,0	M12 / 12.9	135

x	x	x	x	x
x	x	x	x	x
x	x	x	x	x
x	x	x	x	x
x	x	x	x	x
x	x	x	x	x
x	x	x	x	x
x	x	x	x	x
x	x	x	x	x
x	x	x	x	x



MPG 04 - MPG 05

DIMENSIONS MOTOR MOUNTING 2-STAGE

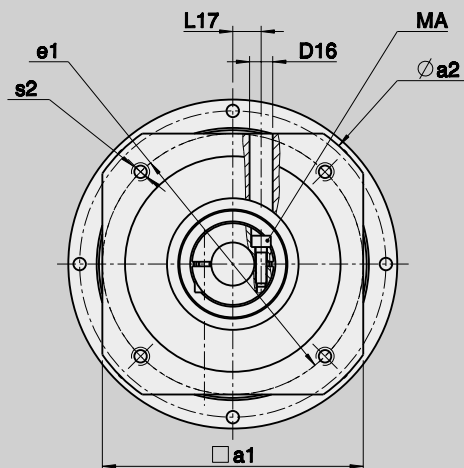
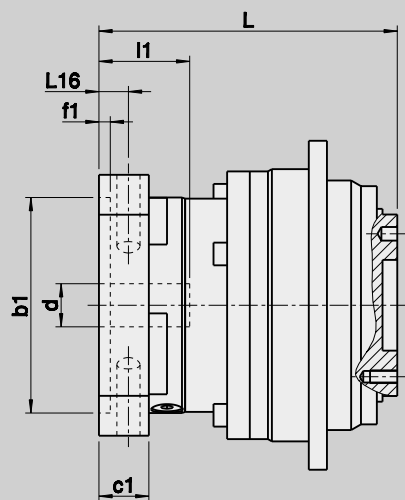

Gearbox dimensions											
d	x	l1	Size	L	L16	L17	c1	f1	D16	Screw type	MA
F7											
28	x	60	04	202,0	18,0	23,0	30,0	6,0	17,5	M10 / 12.9	80
32	x	60		202,0	18,0	23,0	30,0	6,0	17,5	M10 / 12.9	80
38	x	80		222,0	38,0	23,0	50,0	6,0	17,5	M10 / 12.9	80
28	x	60	05	248,0	22,0	27,0	38,0	6,0	25,0	M12 / 12.9	135
32	x	60		248,0	22,0	27,0	38,0	6,0	25,0	M12 / 12.9	135
38	x	80		248,0	22,0	27,0	38,0	6,0	25,0	M12 / 12.9	135
42	x	110		278,0	53,0	37,0	38,0	6,0	25,0	M12 / 12.9	135
48	x	110		278,0	53,0	37,0	38,0	6,0	25,0	M12 / 12.9	135

Motor dimensions								
a1		160	190	160	190	200	250	260
a2		180	220	190	220	250	300	350
b1	G8	110	110	130	130	180	230	250
e1		130	130	165	165	215	265	300
s2		M8	M8	M10	M10	M12	M12	M16
		x16	x16	x20	x20	x24	x24	x32
		∅ 9,0	-	∅ 11,0	-	∅ 13,0	∅ 13,0	-

x		x		x		
x		x		x		
x		x		x		
	x		x	x	x	x
	x		x	x	x	x
	x		x	x	x	x
	x		x	x	x	x

Mounting position:

(underside)

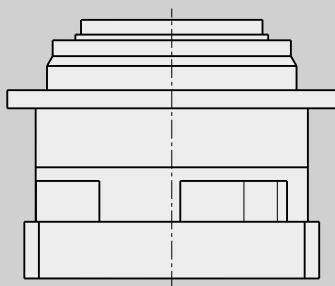

A

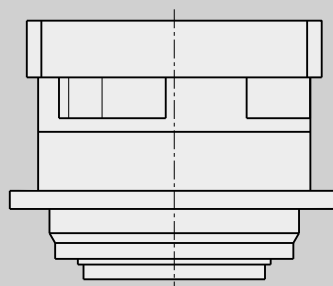

B

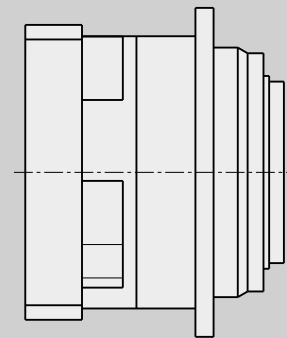

C

Lubrication

The planetary gearboxes are always oil-lubricated, and are supplied filled with oil. In our factories the gearboxes are filled with a synthetic poly-alpha-olefin-based gear oil. The viscosity is 150 cSt. We supply gearboxes with a quantity of oil suitable for the mounting position given in the order. If it is not clear from the order, gearboxes are supplied with a quantity of oil suitable for the vertical mounting position A.

Subsequent change of mounting position

If it is necessary to change the mounting position later, the oil should always be completely drained from the gearbox for safety reasons. The gearbox must then be refilled with the quantity of oil required in the new mounting position as given in our instructions (see following table). Use one of the recommended grades of oil. (see following table).



	Oil quantities for mounting position [cm ³]					
	A		B		C	
Ratio	4-10	12-100	4-10	12-100	4-10	12-100
MPG 04	500	550	500	550	260	300
MPG 05	820	900	820	900	400	550

Recommended oils

Mobil	Optimol
Mobil SHC 629	Optigear Synthetic A 150

Or equivalent oils from other manufacturers.

Caution!

Do not mix mineral and/or synthetic oil grades. This could damage the gearbox.

M P L

TECHNICAL DATA

Technical specifications on this page and in the tables on the following three pages are intended only for rough preselection.

Gear teeth:	spur gear	Lubrication:	lubricated for life
Direction of rotation:	input and output in the same direction	Mounting position:	any, please specify when ordering
Efficiency:	1-stage $\eta \geq 97\%$ 2-stage $\eta \geq 95\%$	Surface protection:	Primer coat RAL 9005 black Flanges of untreated aluminium
Life time:	20000 h	Protection rating:	IP64
Permissible gearbox temperature at housing:	-10 °C to +90 °C		





MPL 050 - MPL 100

TECHNICAL DATA

The following technical specifications in the table are intended only for rough preselection

MPL			050													
			1					2								
Gear stages																
Ratio	i		3	4	5	7	10	12	16	20	28	35	50	70	100	
Max. acceleration torque (max. 1000 cycles per hour)	T _{2bzul}	Nm	32	40	40	40	32	40	40	40	40	40	40	40	32	
Nominal torque on output (with n _{1Nzul})	T _{2Nzul}	Nm	20	25	25	25	15	25	25	25	25	25	25	25	15	
Emergency stop torque (permissible 1000 times during gearbox life time)	T _{2Notzul}	Nm	80	100	100	100	80	100	100	100	100	100	100	100	80	
Permissible average input speed (with T _{2Nzul} and 20 °C ambient temperature)	n _{1mzul}	min ⁻¹	2600	3300	3300	4000	4000	4400	4400	4400	4800	4800	4800	5500	5500	
Max. input speed	n _{1maxzul}	min ⁻¹	8000					8000								
Max. backlash*	j	arcmin	≤ 8					≤ 10								
Torsional rigidity [▲]	C	Nm/arcmin	3,5					3,5								
Max. radial load** (with reference to shaft centre on output shaft)	F _{2rzul}	N	1450					1450								
Max. axial load** (with reference to shaft centre on output shaft)	F _{2azul}	N	1550					1550								
Weight	m	kg	1,9					2,5								
Running noise (with n ₁ = 3000 min ⁻¹ without load)	L _{PA}	dB(A)	≤ 70					≤ 70								
Inertia (with reference to input)	Ø d 9	J ₁	kgcm ²	0,28	0,23	0,21	0,19	0,18	0,26	0,21	0,20	0,19	0,19	0,18	0,18	0,18
	Ø d 11	J ₁	kgcm ²	0,28	0,22	0,20	0,19	0,18	0,26	0,21	0,20	0,19	0,19	0,18	0,18	0,18
	Ø d 14	J ₁	kgcm ²	0,27	0,22	0,20	0,19	0,18	0,26	0,21	0,19	0,18	0,18	0,18	0,18	0,18

MPL			100													
			1					2								
Gear stages																
Ratio	i		3	4	5	7	10	12	16	20	28	35	50	70	100	
Max. acceleration torque (max. 1000 cycles per hour)	T _{2bzul}	Nm	80	100	100	100	80	100	100	100	100	100	100	100	80	
Nominal torque on output (with n _{1Nzul})	T _{2Nzul}	Nm	56	70	70	70	45	70	70	70	70	70	70	70	45	
Emergency stop torque (permissible 1000 times during gearbox life time)	T _{2Notzul}	Nm	200	250	250	215	200	250	250	250	250	250	250	215	200	
Permissible average input speed (with T _{2Nzul} and 20 °C ambient temperature)	n _{1mzul}	min ⁻¹	2300	2900	2900	3100	3100	3500	3500	3500	3800	3800	3800	4500	4500	
Max. input speed	n _{1maxzul}	min ⁻¹	6000					6000								
Max. backlash*	j	arcmin	≤ 8					≤ 10								
Torsional rigidity [▲]	C	Nm/arcmin	10					10								
Max. radial load** (with reference to shaft centre on output shaft)	F _{2rzul}	N	2400					2400								
Max. axial load** (with reference to shaft centre on output shaft)	F _{2azul}	N	1900					1900								
Weight	m	kg	3,8					4,8								
Running noise (with n ₁ = 3000 min ⁻¹ without load)	L _{PA}	dB(A)	≤ 72					≤ 72								
Inertia (with reference to input)	Ø d 9	J ₁	kgcm ²	1,06	0,82	0,74	0,67	0,64	0,95	0,76	0,70	0,65	0,65	0,63	0,63	0,63
	Ø d 11	J ₁	kgcm ²	1,06	0,82	0,74	0,67	0,64	0,95	0,76	0,70	0,65	0,65	0,63	0,63	0,63
	Ø d 14	J ₁	kgcm ²	1,05	0,82	0,73	0,66	0,63	0,94	0,75	0,69	0,65	0,64	0,62	0,62	0,62
	Ø d 19	J ₁	kgcm ²	1,03	0,79	0,71	0,64	0,61	0,91	0,73	0,67	0,62	0,62	0,60	0,60	0,60

[▲]with reference to output

* measured with 2 % nominal torque on output shaft

**charge centre of output shaft at output speed 250 min⁻¹. Please contact us for combined load applications

M P L 2 0 0

TECHNICAL DATA

MPL				200												
Gear stages				1						2						
Ratio	i			3	4	5	7	10	12	16	20	28	35	50	70	100
Max. acceleration torque (max. 1000 cycles per hour)	T_{2bzul}	Nm		200	250	250	250	200	250	250	250	250	250	250	250	200
Nominal torque on output (with n_{1Nzul})	T_{2Nzul}	Nm		135	170	170	170	110	170	170	170	170	170	170	170	110
Emergency stop torque (permissible 1000 times during gearbox life time)	$T_{2Notzul}$	Nm		500	625	625	550	500	625	625	625	625	625	625	550	500
Permissible average input speed (with T_{2Nzul} and 20 °C ambient temperature)	n_{1mzul}	min ⁻¹		2000	2500	2500	2800	2800	3100	3100	3100	3500	3500	3500	4200	4200
Max. input speed	$n_{1maxzul}$	min ⁻¹		4800				4800								
Max. backlash*	j	arcmin		≤ 8				≤ 10								
Torsional rigidity [▲]	C	Nm/arcmin		26				26								
Max. radial load** (with reference to shaft centre on output shaft)	F_{2rzul}	N		4600				4600								
Max. axial load** (with reference to shaft centre on output shaft)	F_{2azul}	N		4000				4000								
Weight	m	kg		9,5				11,8								
Running noise (with $n_1 = 3000$ min ⁻¹ without load)	L_{PA}	dB(A)		≤ 74				≤ 74								
Inertia (with reference to input)	Ø d 9	J_1	kgcm ²	7,08	6,11	5,76	5,48	5,35	6,55	5,83	5,59	5,40	5,40	5,31	5,30	5,30
	Ø d 11	J_1	kgcm ²	7,08	6,11	5,75	5,48	5,34	6,54	5,83	5,59	5,40	5,39	5,30	5,30	5,30
	Ø d 14	J_1	kgcm ²	7,07	6,10	5,75	5,47	5,33	6,54	5,82	5,58	5,39	5,38	5,29	5,29	5,29
	Ø d 19	J_1	kgcm ²	7,03	6,06	5,71	5,43	5,30	6,50	5,78	5,54	5,35	5,35	5,26	5,25	5,25
	Ø d 24	J_1	kgcm ²	6,95	5,98	5,63	5,35	5,22	6,42	5,70	5,46	5,27	5,27	5,18	5,17	5,17
	Ø d 28	J_1	kgcm ²	6,84	5,87	5,51	5,24	5,10	6,30	5,59	5,35	5,16	5,15	5,06	5,06	5,06
	Ø d 32	J_1	kgcm ²	6,66	5,69	5,33	5,06	4,92	6,12	5,41	5,17	4,98	4,97	4,88	4,88	4,88

[▲]with reference to output

* measured with 2 % nominal torque on output shaft

**charge centre of output shaft at output speed 250 min⁻¹. Please contact us for combined load applications



M P L 3 0 0

T E C H N I C A L D A T A

MPL				300														
Gear stages				1					2									
Ratio				i	3	4	5	7	10	12	16	20	28	35	50	70	100	
Max. acceleration torque (max. 1000 cycles per hour)				T _{2bzul}	Nm	400	500	500	500	400	500	500	500	500	500	500	400	
Nominal torque on output (with n _{1Nzul})				T _{2Nzul}	Nm	290	360	360	360	220	360	360	360	360	360	360	220	
Emergency stop torque (permissible 1000 times during gearbox life time)				T _{2Notzul}	Nm	1000	1250	1250	1100	1000	1250	1250	1250	1250	1250	1100	1000	
Permissible average input speed (with T _{2Nzul} and 20 °C ambient temperature)				n _{1mzul}	min ⁻¹	1700	2100	2100	2600	2600	2900	2900	2900	3200	3200	3200	3900	3900
Max. input speed				n _{1maxzul}	min ⁻¹	4500					4500							
Max. backlash*				j	arcmin	≤ 8					≤ 10							
Torsional rigidity [▲]				C	Nm/arcmin	50					50							
Max. radial load** (with reference to shaft centre on output shaft)				F _{2rzul}	N	7500					7500							
Max. axial load** (with reference to shaft centre on output shaft)				F _{2azul}	N	6000					6000							
Weight				m	kg	18,4					23,2							
Running noise (with n ₁ = 3000 min ⁻¹ without load)				L _{PA}	dB(A)	≤ 75					≤ 75							
Inertia (with reference to input)	Ø d 19	J ₁	kgcm ²	16,58	13,48	12,32	11,35	10,82	14,31	12,20	11,47	10,89	10,86	10,58	10,57	10,56		
	Ø d 24	J ₁	kgcm ²	16,48	13,38	12,22	11,25	10,72	14,20	12,10	11,37	10,79	10,76	10,48	10,47	10,46		
	Ø d 28	J ₁	kgcm ²	16,33	13,23	12,08	11,10	10,58	14,06	11,96	11,22	10,64	10,62	10,33	10,32	10,32		
	Ø d 32	J ₁	kgcm ²	16,11	13,01	11,85	10,88	10,35	13,83	11,73	11,00	10,42	10,39	10,11	10,10	10,09		
	Ø d 38	J ₁	kgcm ²	15,57	12,47	11,31	10,34	9,82	13,30	11,20	10,46	9,88	9,86	9,57	9,56	9,56		

▲with reference to output

* measured with 2 % nominal torque on output shaft

**charge centre of output shaft at output speed 250 min⁻¹. Please contact us for combined load applications

MPL 050 - MPL 300

DIMENSIONS 1-STAGE

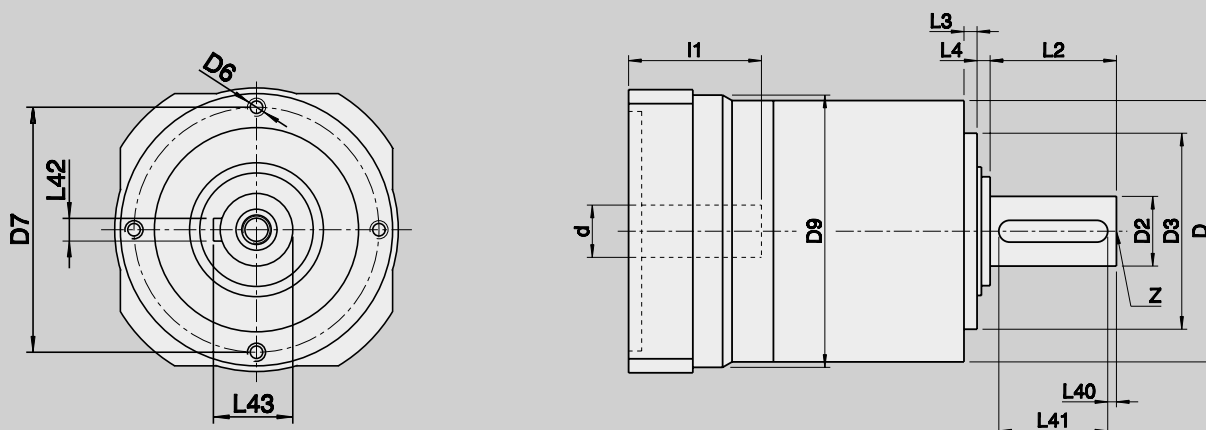

d	x	l1	Size	Ratio	D	D2	x	L2	D3	D6	D7	D9	L3	L4	L40	L41	L42	L43	Z
F7						k6			h6								h9		DIN 332
9	x	20	050	3 - 10	70	16	x	28	52	M5 x 10	62	75	5	3	2	22	5	18,0	D M5
11	x	23																	
14	x	30																	
9	x	20	100	3 - 10	90	22	x	36	68	M6 x 12	80	95	5	5	2	32	6	24,5	D M8
11	x	23																	
14	x	30																	
19	x	40																	
9	x	20	200	3 - 10	120	32	x	58	90	M8 x 16	108	125	6	6	4	50	10	35,0	D M12
11	x	23																	
14	x	30																	
19	x	40																	
24	x	50																	
28	x	60																	
32	x	60																	
19	x	40	300	3 - 10	155	40	x	82	120	M10 x 20	140	160	8	7	4	70	12	43,0	D M16
24	x	50																	
28	x	60																	
32	x	60																	
38	x	80																	



MPL 050 - MPL 300

DIMENSIONS 2-STAGE

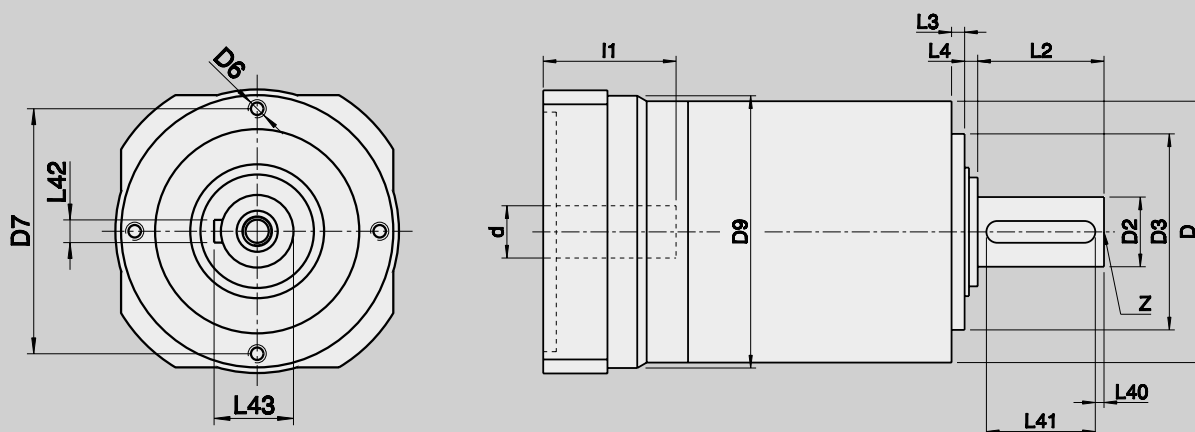

d	x	l1	Size	Ratio	D	D2	x	L2	D3	D6	D7	D9	L3	L4	L40	L41	L42	L43	Z
F7							k6		h6								h9		DIN 332
9	x	20	050	12 - 100	70	16	x	28	52	M5 x 10	62	75	5	3	2	22	5	18,0	D M5
11	x	23																	
14	x	30																	
9	x	20	100	12 - 100	90	22	x	36	68	M6 x 12	80	95	5	5	2	32	6	24,5	D M8
11	x	23																	
14	x	30																	
19	x	40																	
9	x	20	200	12 - 100	120	32	x	58	90	M8 x 16	108	125	6	6	4	50	10	35,0	D M12
11	x	23																	
14	x	30																	
19	x	40																	
24	x	50																	
28	x	60																	
32	x	60																	
19	x	40	300	12 - 100	155	40	x	82	120	M10 x 20	140	160	8	7	4	70	12	43,0	D M16
24	x	50																	
28	x	60																	
32	x	60																	
38	x	80																	

MPL 050 - MPL 300

DIMENSIONS MOTOR MOUNTING 1-STAGE

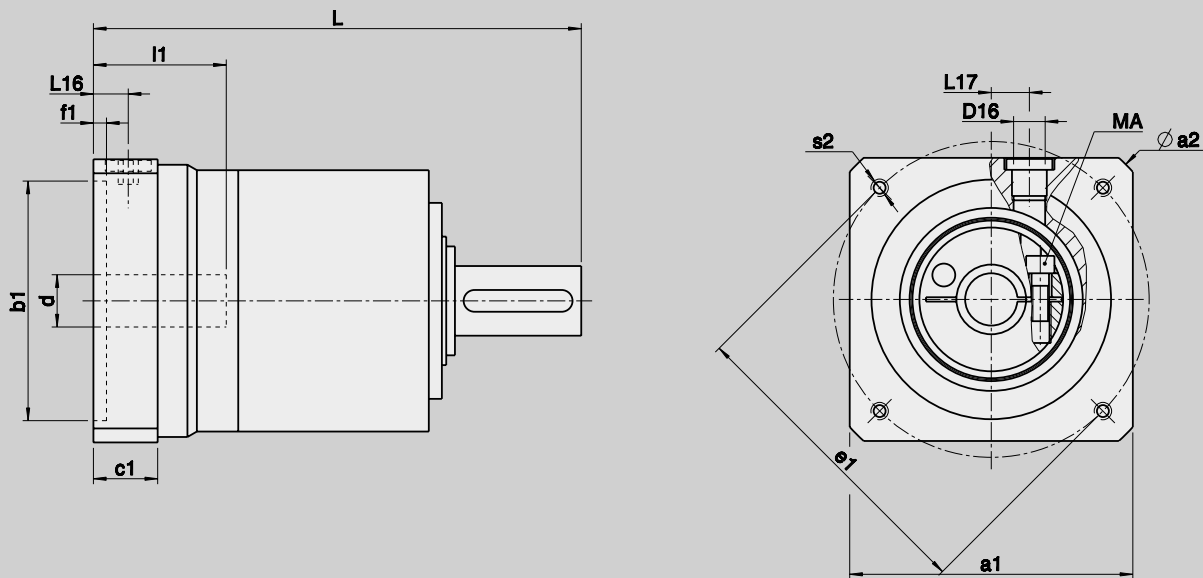

Gearbox dimensions

d	x	l1	Size	L	L16	L17	c1	f1	D16	Screw type	MA
F7											
[Nm]											
9	x	20	050	128,5	10,5	10 - 12	18,5	4,5	M10 x 1	M5 / 12.9	9
11	x	23									
14	x	30									
9	x	20	100	157,5	13,5	12 - 16	24,5	4,5	M12 x 1,5	M6 / 12.9	16
11	x	23									
14	x	30									
19	x	40									
9	x	20	200	224,0	16,0	21 - 24	29,5	6,0	M16 x 1,5	M10 / 12.9	80
11	x	23									
14	x	30									
19	x	40									
24	x	50									
28	x	60									
32	x	60									
19	x	40	300	289,5	20,5	24 - 26	36,5	6,0	M20 x 1,5	M10/12.9	80
24	x	50									
28	x	60									
32	x	60									
38	x	80									



Motor dimensions

a1		75	75	75	95	95	75	75	95	75	95	95	95	120	115	120	120	130	130	150	140	150	160	150	160	200	250
a2		90	90	90	120	120	90	90	120	102	120	120	120	140	140	140	160	160	160	186	190	186	190	186	190	250	300
b1	G8	40	40	50	50	50	60	60	60	60	70	70	80	80	95	95	95	110	110	110	110	110	110	130	130	180	230
e1		63	63	70	70	95	75	75	75	90	85	90	100	100	115	115	130	130	130	130	145	145	165	165	165	215	265
s2		M4 x8	M5 x10	M5 x10	M5 x10	M6 x12	M5 x10	M6 x12	M6 x12	M5 x10	M6 x12	M6 x12	M6 x12	M6 x12	M8 x16	M8 x16	M8 x16	M8 x16	M8 x16	M8 x16	M8 x16	M8 x16	M10 x20	M10 x20	M10 x20	M12 x24	M12 x24
		-	-	-	-	-	-	-	-	-	-	-	-	-	-	-	-	∅ 9,0	-	-	-	-	-	-	∅ 11,0	-	-

x	x	x			x	x			x	x		x																
x	x	x			x	x			x	x		x																
x	x	x			x	x			x	x		x																
			x	x			x				x	x													x			
			x	x			x				x	x												x				
			x	x			x				x	x												x				
			x	x			x				x	x												x				
													x		x	x			x		x		x		x	x	x	x
													x		x	x			x		x		x		x	x	x	x
													x		x	x			x		x		x		x	x	x	x
													x		x	x			x		x		x		x	x	x	x

MPL 050 - MPL 300

DIMENSIONS MOTOR MOUNTING 2-STAGE

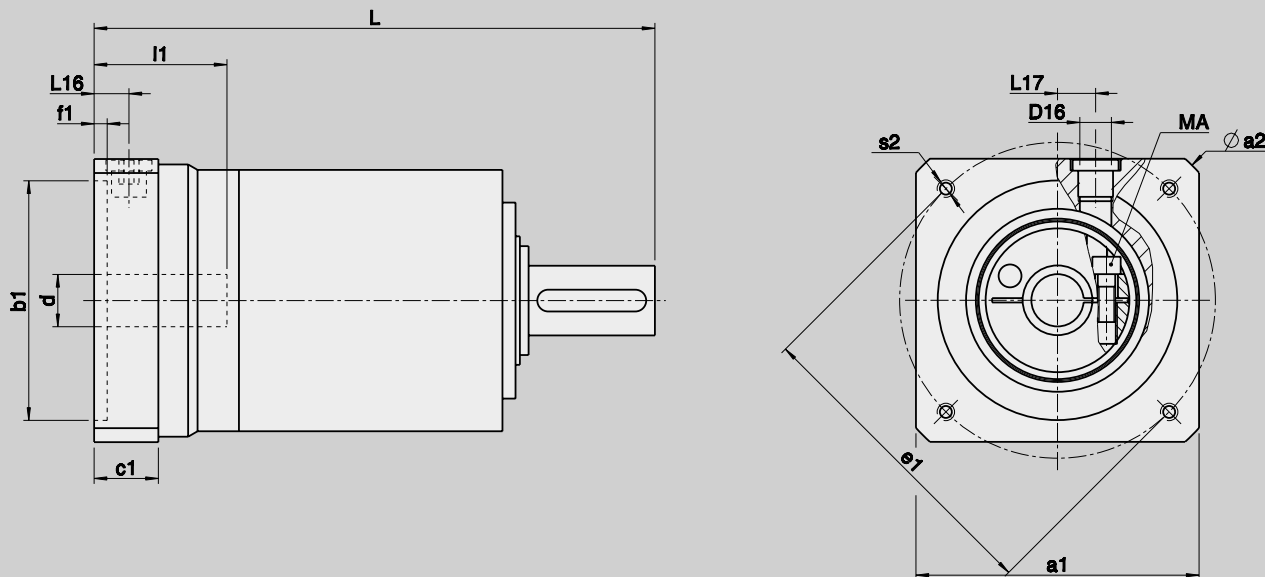

Gearbox dimensions

d	x	l1	Size	L	L16	L17	c1	f1	D16	Screw type	MA
F7											[Nm]
9	x	20	050	150,5	10,5	10 - 12	18,5	4,5	M10 x 1	M5 / 12.9	9
11	x	23									
14	x	30									
9	x	20	100	184,5	13,5	12 - 16	24,5	4,5	M12 x 1,5	M6 / 12.9	16
11	x	23									
14	x	30									
19	x	40									
9	x	20	200	257,5	16,0	21 - 24	29,5	6,0	M16 x 1,5	M10 / 12.9	80
11	x	23									
14	x	30									
19	x	40									
24	x	50									
28	x	60									
32	x	60									
19	x	40	300	331,5	20,5	24 - 26	36,5	6,0	M20 x 1,5	M10 / 12.9	80
24	x	50									
28	x	60									
32	x	60									
38	x	80									



Motor dimensions

a1		75	75	75	95	95	75	75	95	75	95	95	95	120	115	120	120	130	130	150	140	150	160	150	160	200	250
a2		90	90	90	120	120	90	90	120	102	120	120	120	140	140	140	160	160	160	186	190	186	190	186	190	250	300
b1	G8	40	40	50	50	50	60	60	60	60	70	70	80	80	95	95	95	110	110	110	110	110	110	130	130	180	230
e1		63	63	70	70	95	75	75	75	90	85	90	100	100	115	115	130	130	130	130	145	145	165	165	165	215	265
s2		M4 x8	M5 x10	M5 x10	M5 x10	M6 x12	M5 x10	M6 x12	M6 x12	M5 x10	M6 x12	M6 x12	M6 x12	M6 x12	M8 x16	M8 x16	M8 x16	M8 x16	M8 x16	M8 x16	M8 x16	M8 x16	M10 x20	M10 x20	M10 x20	M12 x24	M12 x24
		-	-	-	-	-	-	-	-	-	-	-	-	-	-	-	-	∅ 9,0	-	-	-	-	-	-	∅ 11,0	-	-

x	x	x			x	x			x	x		x																
x	x	x			x	x			x	x		x																
x	x	x			x	x			x	x		x																
			x	x			x				x	x		x			x							x				
			x	x			x				x	x		x			x						x					
			x	x			x				x	x		x			x						x					
			x	x			x				x	x		x			x						x					
													x		x	x		x				x		x		x	x	x
													x		x	x		x				x		x		x	x	x
													x		x	x		x				x		x		x	x	x
													x		x	x		x				x		x		x	x	x

ANGULAR SERVO SPIRAL BEVEL GEARBOXES

Unlike with a spiral bevel gearbox, the axes of drive pinion and bevel gear are offset on servo spiral bevel gearboxes, in other words they do not intersect.

The hypoid gearing offers higher ratios in one stage and much quieter running noise.

The convincing features of the servo spiral bevel gearbox are a low and constant backlash coupled with high nominal speeds.

The servo spiral bevel gearbox can also be used as a multi-stage gearbox in combination with low-backlash planetary gears if greater capacities are required.

SK (N)		
050	100	200
Page 70	Page 71	Page 71

SKH		
050	100	200
Page 76	Page 77	Page 77

SKPR (N)			
01	02	03	04
Page 83	Page 83	Page 84	Page 85

SKPG			
01	02	03	04
Page 91	Page 91	Page 92	Page 93



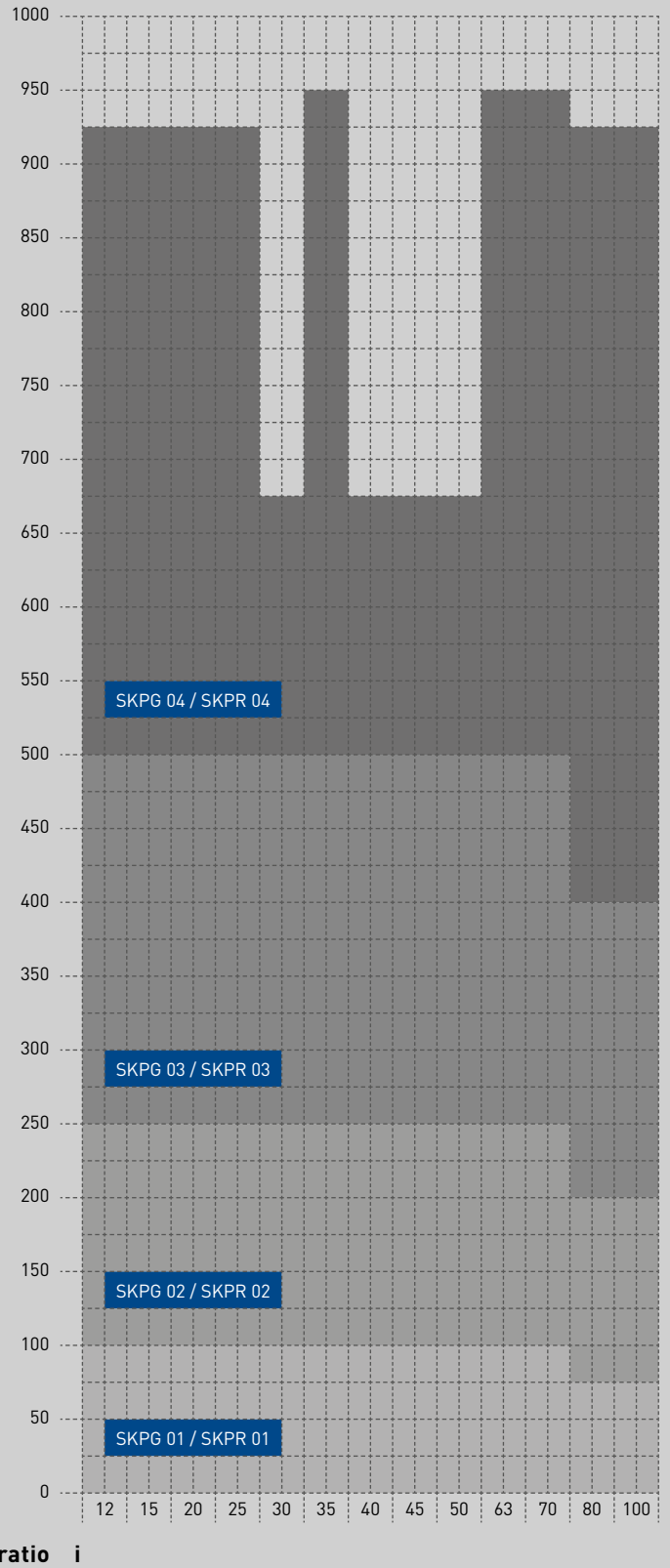
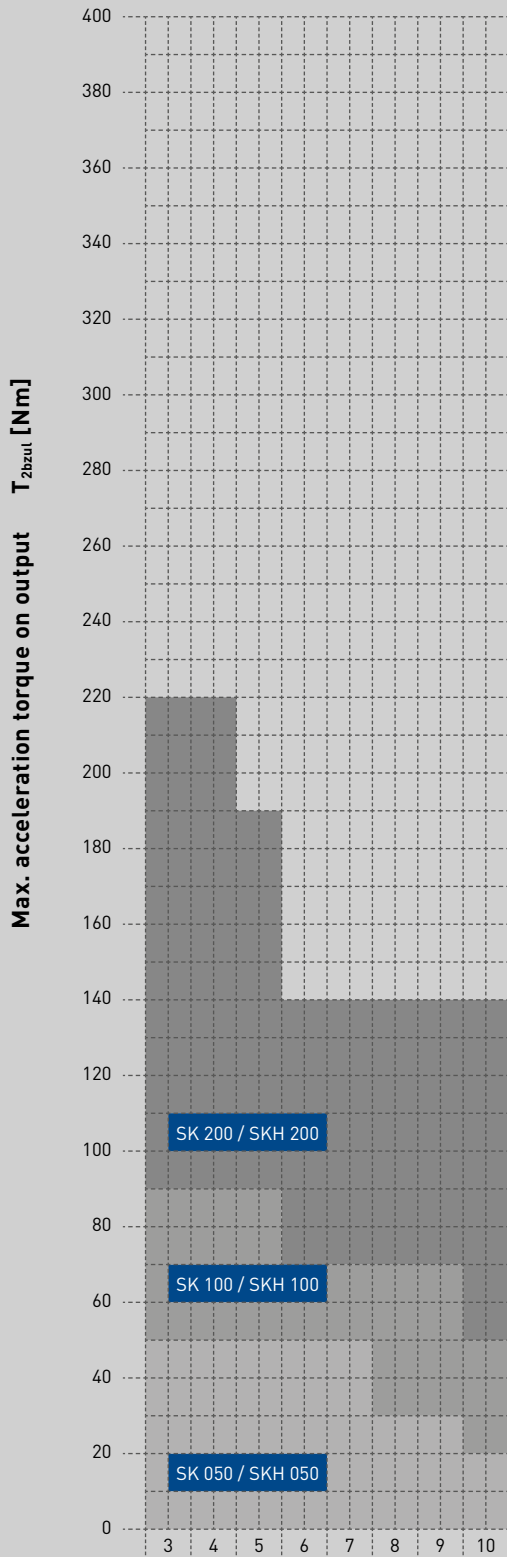

SK(N)

TECHNICAL DATA

Technical specifications on this page and in the tables on the following two pages are intended only for rough preselection.

Gear teeth:	SK(N) 050 – SK(N) 200 Klingelnberg spiral bevel toothing
Direction of rotation:	The opposite direction when facing C and A
Efficiency:	Size 050 $\eta \sim 0.95$ Size 100 $\eta \sim 0.95$ Size 200 $\eta \sim 0.94$
Life time:	20000 h
Permissible gearbox temperature at housing:	-10 °C to +90 °C
Lubrication:	lubricated for life
Mounting position:	Any, please specify when ordering
Surface protection:	Primer coat RAL 9005 black
Protection rating:	IP 54

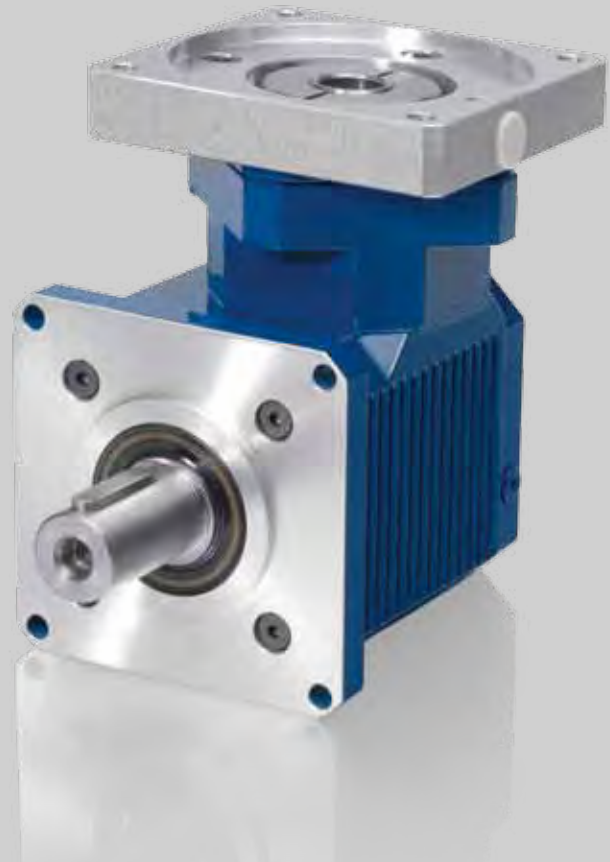

SK(N)			050								
Ratio	i		3	4	5	6	7	8	9	10	
Max. acceleration torque (max. 1000 cycles per hour)	T_{2bzul}	Nm	54	54	54	51	51	30	27	23	
Nominal torque on output shaft ([at n_{1Nzul}])	T_{2Nzul}	Nm	40	40	40	35	35	22	20	16	
Emergency stop torque (permissible 1000 times during gearbox life time)	$T_{2Notzul}$	Nm	72	72	72	70	70	40	36	30	
Permissible average input speed (with T_{2Nzul} and 20 °C ambient temperature)	n_{1mzul}	min ⁻¹	4000	4000	4000	4000	4000	4000	4000	4000	
Max. input speed	$n_{1maxzul}$	min ⁻¹	7500								
Max. backlash*	j	arcmin	standard ≤ 5 / reduced ≤ 3								
Torsional rigidity [▲]	C	Nm/arcmin	on request								
Max. radial load** (with reference to shaft centre on output shaft)	F_{2rzul}	N	900								
Max. axial load** (with reference to shaft centre on output shaft)	F_{2azul}	N	700								
Weight	m	kg	approx. 3,2								
Running noise (with $n_1 = 3000 \text{ min}^{-1}$ without load)	L_{PA}	dB(A)	approx. 65 / distance of 1 m								
Inertia (with reference to input)	$\varnothing d 9$	J_1	kgcm ²	0,65	0,54	0,49	0,47	0,45	0,44	0,43	0,42
	$\varnothing d 11$	J_1	kgcm ²	0,65	0,54	0,49	0,47	0,45	0,44	0,43	0,42
	$\varnothing d 14$	J_1	kgcm ²	0,65	0,54	0,49	0,47	0,45	0,44	0,43	0,42

[▲]with reference to output

* measured with 2 % nominal torque on output shaft

**charge centre of output shaft at output speed 250 min⁻¹. Please contact us for combined load applications



SK(N) 050 - SK(N) 200

TECHNICAL DATA

The following technical specifications in the table are intended only for rough preselection

SK(N)			100								
Ratio	i		3	4	5	6	7	8	9	10	
Max. acceleration torque (max. 1000 cycles per hour)	T_{2bzul}	Nm	93	93	93	72	70	70	70	48	
Nominal torque on output shaft [[at n_{1Nzul}]]	T_{2Nzul}	Nm	68	64	64	50	48	48	48	35	
Emergency stop torque (permissible 1000 times during gearbox life time)	$T_{2Notzul}$	Nm	124	124	124	96	94	94	94	64	
Permissible average input speed (with T_{2Nzul} and 20 °C ambient temperature)	n_{1mzul}	min ⁻¹	4000	4000	4000	4000	4000	4000	4000	4000	
Max. input speed	$n_{1maxzul}$	min ⁻¹	7500								
Max. backlash*	j	arcmin	standard ≤ 5 / reduced ≤ 3								
Torsional rigidity [▲]	C	Nm/arcmin	on request								
Max. radial load** (with reference to shaft centre on output shaft)	F_{2rzul}	N	1400								
Max. axial load** (with reference to shaft centre on output shaft)	F_{2azul}	N	1000								
Weight	m	kg	approx. 5,4								
Running noise (with $n_1 = 3000$ min ⁻¹ without load)	L_{PA}	dB(A)	approx. 65 / distance of 1 m								
Inertia (with reference to input)	Ø d 9	J_1	kgcm ²	1,65	1,38	1,28	1,22	1,19	1,16	1,15	1,14
	Ø d 11	J_1	kgcm ²	1,65	1,38	1,28	1,22	1,19	1,16	1,15	1,14
	Ø d 14	J_1	kgcm ²	1,65	1,38	1,28	1,22	1,19	1,16	1,15	1,14
	Ø d 19	J_1	kgcm ²	1,65	1,38	1,28	1,22	1,19	1,16	1,15	1,14

SK(N)			200								
Ratio	i		3	4	5	6	7	8	9	10	
Max. acceleration torque (max. 1000 cycles per hour)	T_{2bzul}	Nm	217	217	185	136	136	136	135	135	
Nominal torque on output shaft [[at n_{1Nzul}]]	T_{2Nzul}	Nm	150	150	120	100	100	100	90	90	
Emergency stop torque (permissible 1000 times during gearbox life time)	$T_{2Notzul}$	Nm	290	290	244	182	182	182	180	180	
Permissible average input speed (with T_{2Nzul} and 20 °C ambient temperature)	n_{1mzul}	min ⁻¹	4000	4000	4000	4000	4000	4000	4000	4000	
Max. input speed	$n_{1maxzul}$	min ⁻¹	6500								
Max. backlash*	j	arcmin	standard ≤ 4 / reduced ≤ 2								
Torsional rigidity [▲]	C	Nm/arcmin	on request								
Max. radial load** (with reference to shaft centre on output shaft)	F_{2rzul}	N	2200								
Max. axial load** (with reference to shaft centre on output shaft)	F_{2azul}	N	1600								
Weight	m	kg	approx. 9,5								
Running noise (with $n_1 = 3000$ min ⁻¹ without load)	L_{PA}	dB(A)	approx. 65 / distance of 1 m								
Inertia (with reference to input)	Ø d 11	J_1	kgcm ²	6,78	5,54	5,00	4,72	4,55	4,45	4,35	4,30
	Ø d 14	J_1	kgcm ²	6,78	5,54	5,00	4,72	4,55	4,45	4,35	4,30
	Ø d 19	J_1	kgcm ²	6,78	5,54	5,00	4,72	4,55	4,45	4,35	4,30
	Ø d 24	J_1	kgcm ²	6,78	5,54	5,00	4,72	4,55	4,45	4,35	4,30
	Ø d 28	J_1	kgcm ²	6,78	5,54	5,00	4,72	4,55	4,45	4,35	4,30

▲with reference to output

* measured with 2 % nominal torque on output shaft

**charge centre of output shaft at output speed 250 min⁻¹. Please contact us for combined load applications

SK(N) 050 - SK(N) 200

DIMENSIONS

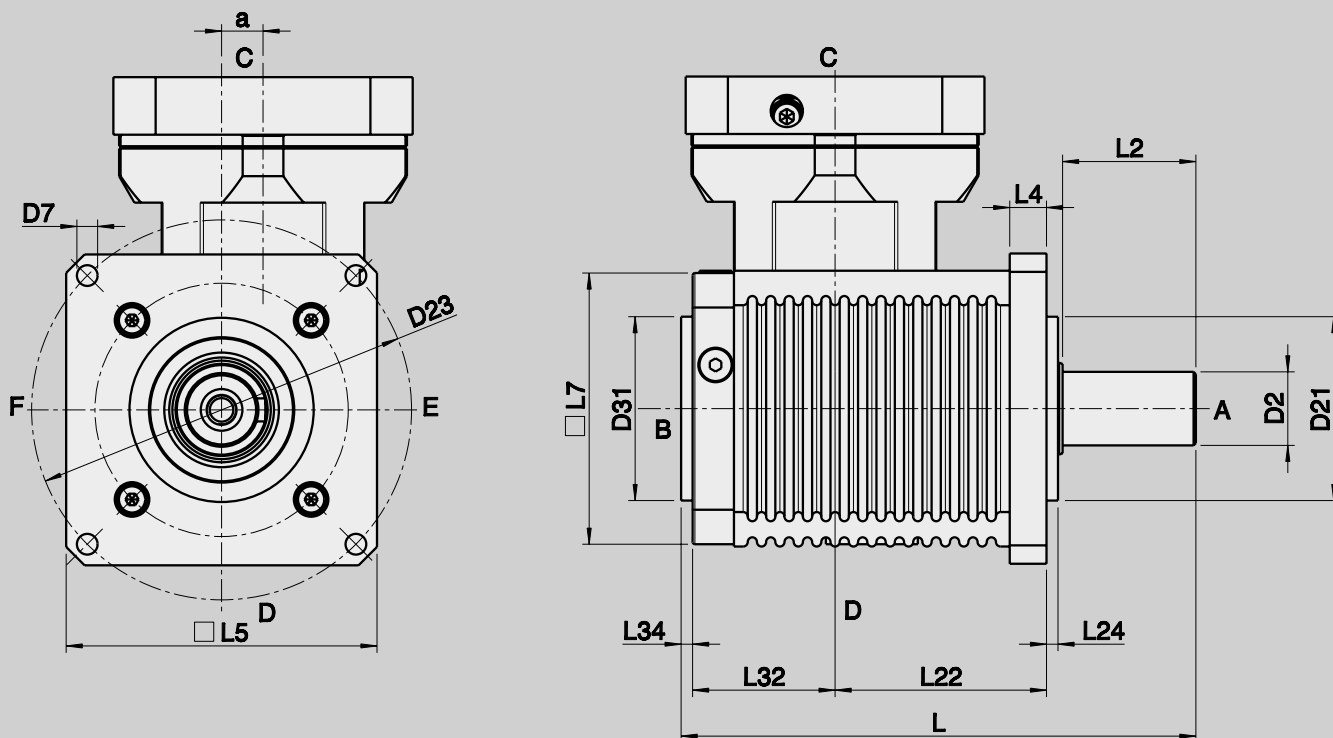

Design SKN, output shaft with keyway DIN 6885

d	x	l1	Size	D2	D7	D21	D23	D31	a	L	L2
G7				k6		g6		g6			
9	x	20									
11	x	23	050	16	6,6	50	100	50	8	134	28
14	x	30									
9	x	20									
11	x	23									
14	x	30	100	22	9	60	120	60	12	165	36
19	x	40									
11	x	23									
14	x	30									
19	x	40	200	32	9	80	165	80	18	224	58
24	x	50									
28	x	60									



d	x	l1	Größe	L4	L5	L7	L22	L24	L32	L34
G7										
9	x	20	050	7,5	85	75	52,5	2,5	46	2,5
11	x	23								
14	x	30								
9	x	20	100	10	100	90	70	3	51	3
11	x	23								
14	x	30								
19	x	40								
11	x	23	200	16	135	120	92	5	62	5
14	x	30								
19	x	40								
24	x	50								
28	x	60								

SK(N) 050 - SK(N) 200
DIMENSIONS MOTOR MOUNTING

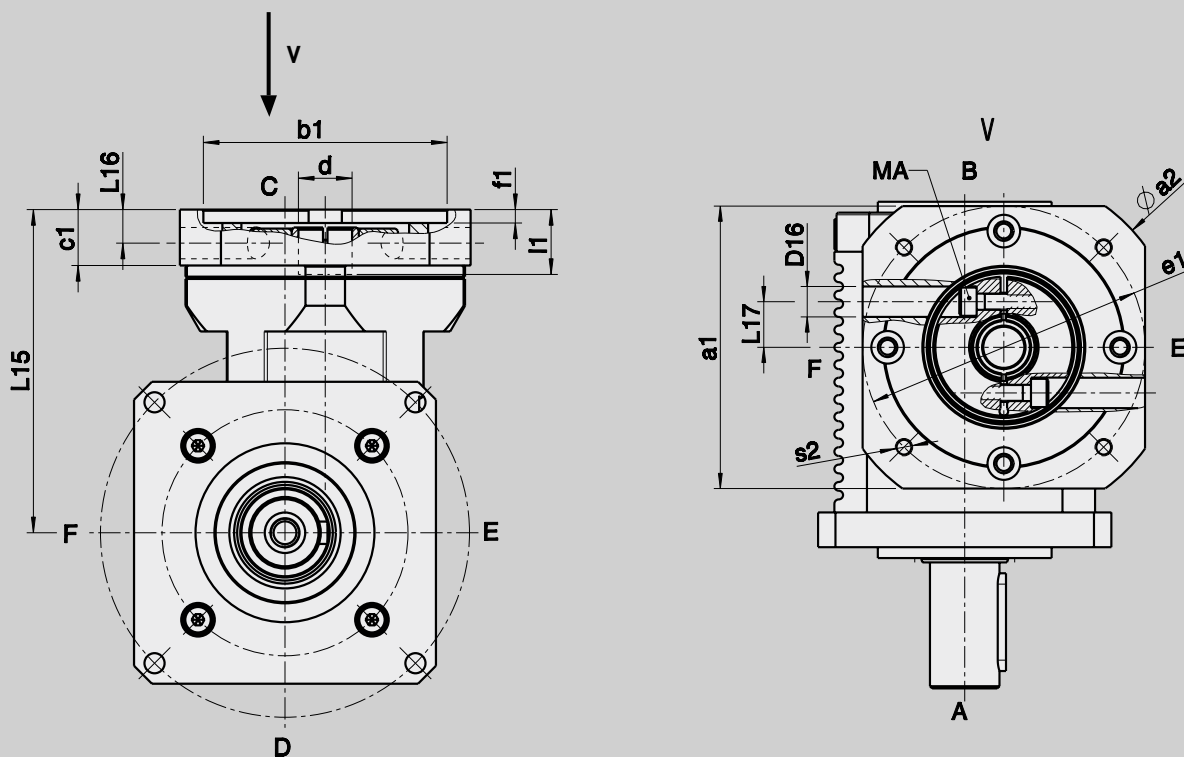

Gearbox dimensions

d	x	l1	Size	l15	l16	l17	c1	f1	D16	Screw type	MA
											(Nm)
9	x	20	050	98,5	9,5	10	16	4,5	8,5	M6 / 12,9	18
11	x	23		98,5	9,5	10	16	4,5	8,5	M6 / 12,9	18
14	x	30		98,5	9,5	10	16	4,5	8,5	M6 / 12,9	18
9	x	20	100	125	13	12,5	22	5	10	M6 / 12,9	18
11	x	23		125	13	12,5	22	5	10	M6 / 12,9	18
14	x	30		125	13	12,5	22	5	10	M6 / 12,9	18
19	x	40		125	13	12,5	22	5	10	M6 / 12,9	18
11	x	23	200	145	15	16,5	25	5	14	M6 / 12,9	18
14	x	30		145	15	16,5	25	5	14	M6 / 12,9	18
19	x	40		145	15	16,5	25	5	14	M8 / 12,9	39
24	x	50		145	15	16,5	25	5	14	M8 / 12,9	43
28	x	60		145	15	16,5	25	5	14	M8 / 12,9	43



Motor dimensions

a1		75	75	75	90	95	95	95	95	115	125	125	125	125	130	140	140	200
a2		90	90	100	120	120	120	120	120	140	140	140	140	140	160	160	190	250
b1	G8	50	60	70	80	50	60	70	80	95	60	70	80	95	110	110	130	180
e1		70	75	85	100	70	75	85	100	115	75	85	100	115	130	130	165	215
s2		M5 x10	M5 x10	M6 x12	M6 x12	M5 x10	M5 x10	M6 x12	M6 x12	M8 x16	M5 x10	M6 x12	M6 x12	M8 x16	M8 x16	M8 x16	M10 x20	M12 x24
		-	∅ 5,5	∅ 7,0	∅ 7,0	-	∅ 5,5	∅ 7,0	∅ 7,0	∅ 9,0	-	-	-	∅ 9,0	∅ 9,0	∅ 9,0	∅ 11,0	-

	x	x	x	x					x						x		
	x	x	x	x					x						x		
	x	x	x	x					x						x		
					x	x	x	x	x					x		x	
					x	x	x	x	x					x		x	
					x	x	x	x	x					x		x	
										x	x	x	x	x		x	x
										x	x	x	x	x		x	x
										x	x	x	x	x		x	x

SKH

TECHNICAL DATA

Technical specifications on this page and in the tables on the following two pages are intended only for rough preselection.

Gear teeth:	SKH 050 – SKH 200 Klingelnberg spiral bevel toothing
Direction of rotation:	The opposite direction when facing C and A
Efficiency:	Size 050 $\eta \sim 0.95$ Size 100 $\eta \sim 0.95$ Size 200 $\eta \sim 0.94$
Life time:	20000 h
Permissible gearbox temperature at housing:	-10 °C to +90 °C
Lubrication:	lubricated for life
Mounting position:	Any, please specify when ordering
Surface protection:	Primer coat RAL 9005 black
Protection rating:	IP 54



SKH				050							
Ratio	i			3	4	5	6	7	8	9	10
Max. acceleration torque (max. 1000 cycles per hour)	T_{2bzul}	Nm		54	54	54	51	51	30	27	23
Nominal torque on output shaft (at n_{1Nzul})	T_{2Nzul}	Nm		40	40	40	35	35	22	20	16
Emergency stop torque (permissible 1000 times during gearbox life time)	$T_{2Notzul}$	Nm		72	72	72	70	70	40	36	30
Permissible average input speed (with T_{2Nzul} and 20 °C ambient temperature)	n_{1mzul}	min ⁻¹		4000							
Max. input speed	$n_{1maxzul}$	min ⁻¹		7500							
Max. backlash*	j	arcmin		standard ≤ 5 / reduced ≤ 3							
Torsional rigidity [▲]	C	Nm/arcmin		on request							
Max. radial load** (with reference to shaft centre on output shaft)	F_{2rzul}	N		900							
Max. axial load** (with reference to shaft centre on output shaft)	F_{2azul}	N		700							
Weight	m	kg		approx. 3,2							
Running noise (with $n_1 = 3000$ min ⁻¹ without load)	L_{PA}	dB(A)		approx. 65 / distance of 1 m							
Inertia (with reference to input)	$\varnothing d 9$	J_1	kgcm ²	0,65	0,54	0,49	0,47	0,45	0,44	0,43	0,42
	$\varnothing d 11$	J_1	kgcm ²	0,65	0,54	0,49	0,47	0,45	0,44	0,43	0,42
	$\varnothing d 14$	J_1	kgcm ²	0,65	0,54	0,49	0,47	0,45	0,44	0,43	0,42

[▲]with reference to output

* measured with 2 % nominal torque on output shaft

**charge centre of output shaft at output speed 250 min⁻¹. Please contact us for combined load applications



SKH 050 - SKH 200

TECHNICAL DATA

The following technical specifications in the table are intended only for rough preselection

SKH			100								
Ratio	i		3	4	5	6	7	8	9	10	
Max. acceleration torque (max. 1000 cycles per hour)	T_{2bzul}	Nm	93	93	93	72	70	70	70	48	
Nominal torque on output shaft (at n_{1Nzul})	T_{2Nzul}	Nm	68	64	64	50	48	48	48	35	
Emergency stop torque (permissible 1000 times during gearbox life time)	$T_{2Notzul}$	Nm	124	124	124	96	94	94	94	64	
Permissible average input speed (with T_{2Nzul} and 20 °C ambient temperature)	n_{1mzul}	min ⁻¹	4000								
Max. input speed	$n_{1maxzul}$	min ⁻¹	7500								
Max. backlash*	j	arcmin	standard ≤ 5 / reduced ≤ 3								
Torsional rigidity [▲]	C	Nm/arcmin	on request								
Max. radial load** (with reference to shaft centre on output shaft)	F_{2rzul}	N	1400								
Max. axial load** (with reference to shaft centre on output shaft)	F_{2azul}	N	1000								
Weight	m	kg	approx. 5,4								
Running noise (with $n_1 = 3000$ min ⁻¹ without load)	L_{PA}	dB(A)	approx. 65 / distance of 1 m								
Inertia (with reference to input)	Ø d 9	J_1	kgcm ²	1,65	1,38	1,28	1,22	1,19	1,16	1,15	1,14
	Ø d 11	J_1	kgcm ²	1,65	1,38	1,28	1,22	1,19	1,16	1,15	1,14
	Ø d 14	J_1	kgcm ²	1,65	1,38	1,28	1,22	1,19	1,16	1,15	1,14
	Ø d 19	J_1	kgcm ²	1,65	1,38	1,28	1,22	1,19	1,16	1,15	1,14

SKH			200								
Ratio	i		3	4	5	6	7	8	9	10	
Max. acceleration torque (max. 1000 cycles per hour)	T_{2bzul}	Nm	217	217	185	136	136	136	135	135	
Nominal torque on output shaft (at n_{1Nzul})	T_{2Nzul}	Nm	150	150	120	100	100	100	90	90	
Emergency stop torque (permissible 1000 times during gearbox life time)	$T_{2Notzul}$	Nm	290	290	244	182	182	182	180	180	
Permissible average input speed (with T_{2Nzul} and 20 °C ambient temperature)	n_{1mzul}	min ⁻¹	4000								
Max. input speed	$n_{1maxzul}$	min ⁻¹	6500								
Max. backlash*	j	arcmin	standard ≤ 4 / reduced ≤ 2								
Torsional rigidity [▲]	C	Nm/arcmin	on request								
Max. radial load** (with reference to shaft centre on output shaft)	F_{2rzul}	N	2200								
Max. axial load** (with reference to shaft centre on output shaft)	F_{2azul}	N	1600								
Weight	m	kg	approx. 9,5								
Running noise (with $n_1 = 3000$ min ⁻¹ without load)	L_{PA}	dB(A)	approx. 68 / distance of 1 m								
Inertia (with reference to input)	Ø d 11	J_1	kgcm ²	6,78	5,54	5,00	4,72	4,55	4,45	4,35	4,30
	Ø d 14	J_1	kgcm ²	6,78	5,54	5,00	4,72	4,55	4,45	4,35	4,30
	Ø d 19	J_1	kgcm ²	6,78	5,54	5,00	4,72	4,55	4,45	4,35	4,30
	Ø d 24	J_1	kgcm ²	6,78	5,54	5,00	4,72	4,55	4,45	4,35	4,30
	Ø d 28	J_1	kgcm ²	6,78	5,54	5,00	4,72	4,55	4,45	4,35	4,30

▲with reference to output
 * measured with 2 % nominal torque on output shaft
 **charge centre of output shaft at output speed 250 min⁻¹. Please contact us for combined load applications

SKH 050 - SKH 200

DIMENSIONS

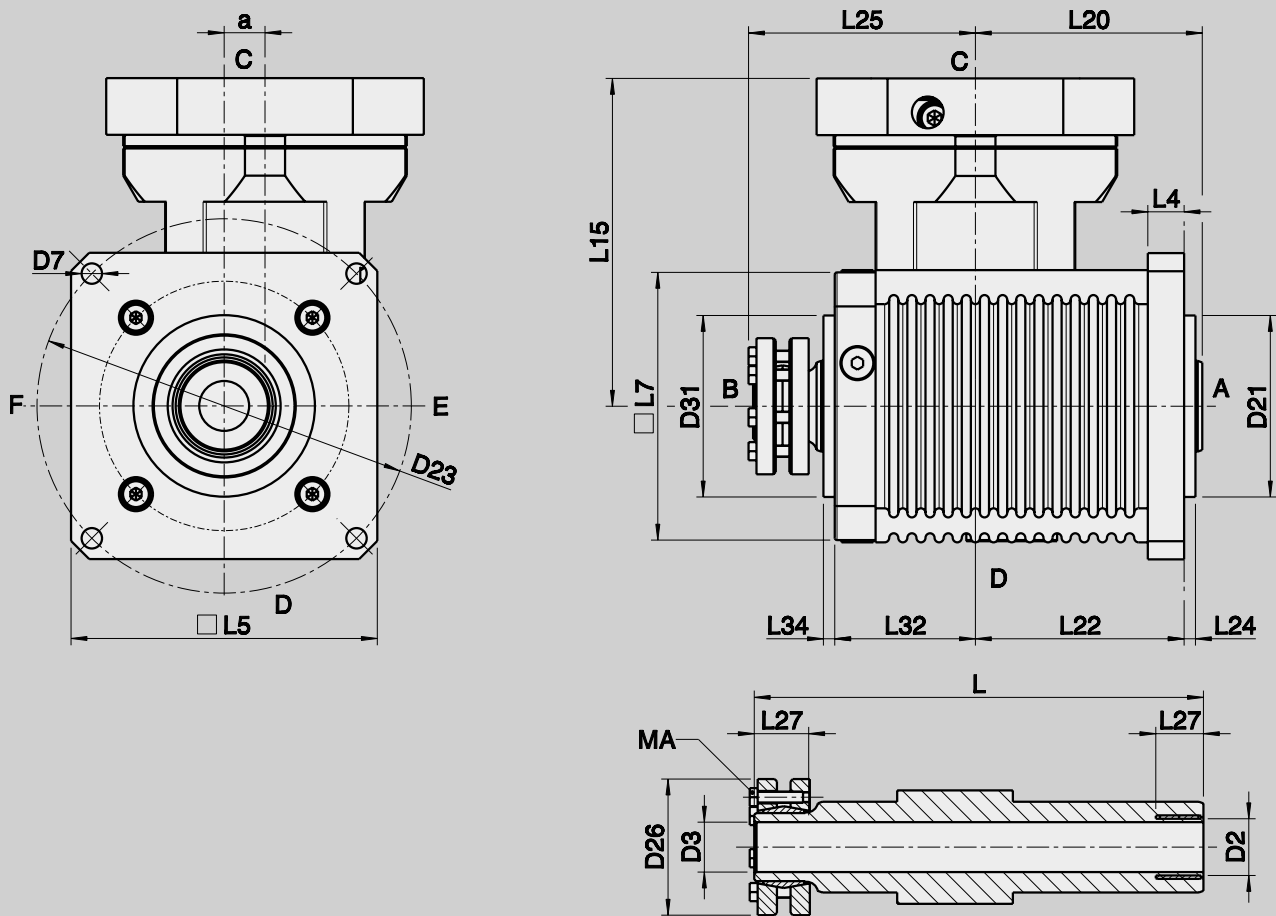

The required clamping torques MA can be found on the shrink disc.

d	x	l1	Size	D2/D3	D7	D21	D23	D26	D31	a	L	L4
G7				H7		g6			g6			
9	x	20	050	12	6,6	50	100	40	50	8	125,5	7,5
11	x	23										
14	x	30										
9	x	20	100	18	9	60	120	50	60	12	154	10
11	x	23										
14	x	30										
19	x	40										
11	x	23	200	25	9	80	165	60	80	18	198	16
14	x	30										
19	x	40										
24	x	50										
28	x	60										



The required clamping torques MA can be found on the shrink disc.

d	x	l1	Größe	L5	L7	L20	L22	L24	L25	L27	L32	L34	MA
G7													
9	x	20	050	85	75	57	52,5	2,5	71,5	17,5	46	2,5	See separate note!
11	x	23											
14	x	30											
9	x	20	100	100	90	75	70	3	82	21	51	3	
11	x	23											
14	x	30											
19	x	40											
11	x	23	200	135	120	100	92	5	100	21	62	5	
14	x	30											
19	x	40											
24	x	50											
28	x	60											

SKH 050 - SKH 200

DIMENSIONS MOTOR MOUNTING

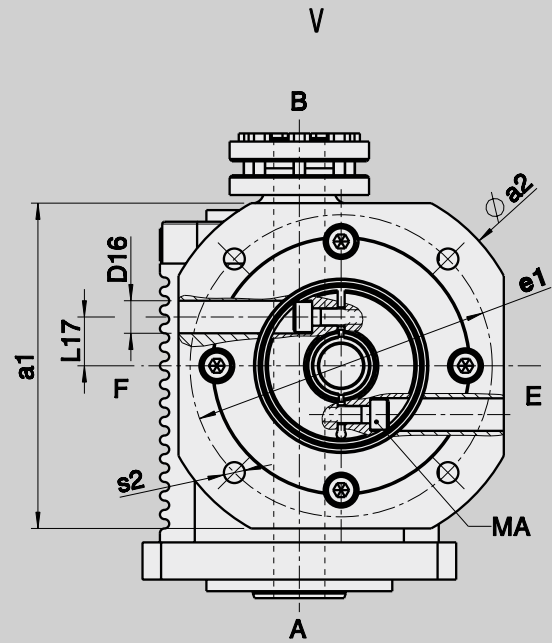
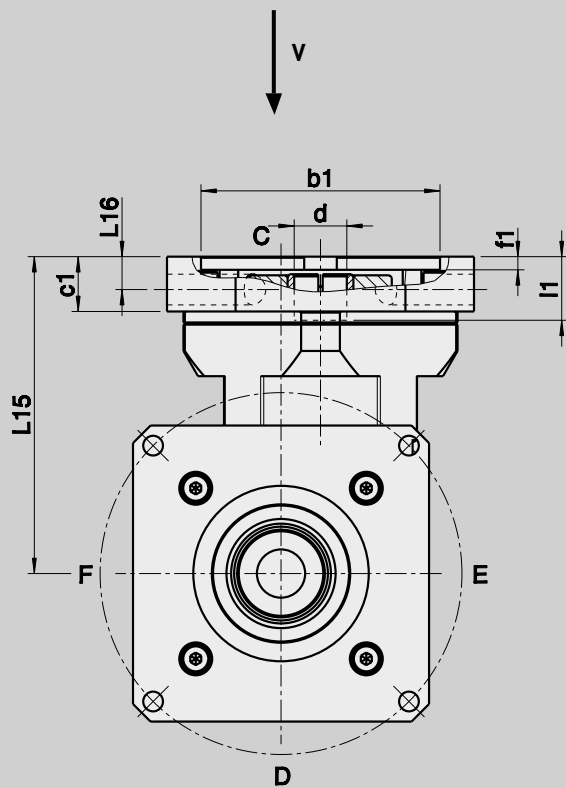

Gearbox dimensions

d	x	l1	Size	l15	l16	l17	c1	f1	D16	Screw type	MA
											(Nm)
9	x	20	050	98.5	9.5	10	16	4.5	8.5	M6 / 12,9	18
11	x	23		98.5	9.5	10	16	4.5	8.5	M6 / 12,9	18
14	x	30		98.5	9.5	10	16	4.5	8.5	M6 / 12,9	18
9	x	20	100	125	13	12.5	22	5	10	M6 / 12,9	18
11	x	23		125	13	12.5	22	5	10	M6 / 12,9	18
14	x	30		125	13	12.5	22	5	10	M6 / 12,9	18
19	x	40		125	13	12.5	22	5	10	M6 / 12,9	18
11	x	23	200	145	15	16.5	25	5	14	M6 / 12,9	18
14	x	30		145	15	16.5	25	5	14	M6 / 12,9	18
19	x	40		145	15	16.5	25	5	14	M8 / 12,9	39
24	x	50		145	15	16.5	25	5	14	M8 / 12,9	43
28	x	60		145	15	16.5	25	5	14	M8 / 12,9	43



Motor dimensions

a1		75	75	75	90	95	95	95	95	115	125	125	125	125	130	140	140	200
a2		90	90	100	120	120	120	120	120	140	140	140	140	140	160	160	190	250
b1	G8	50	60	70	80	50	60	70	80	95	60	70	80	95	110	110	130	180
e1		70	75	85	100	70	75	85	100	115	75	85	100	115	130	130	165	215
s2		M5 x10	M5 x10	M6 x12	M6 x12	M5 x10	M5 x10	M6 x12	M6 x12	M8 x16	M5 x10	M6 x12	M6 x12	M8 x16	M8 x16	M8 x16	M10 x20	M12 x24
		-	∅ 5,5	∅ 7,0	∅ 7,0	-	∅ 5,5	∅ 7,0	∅ 7,0	∅ 9,0	-	-	-	∅ 9,0	∅ 9,0	∅ 9,0	∅ 11,0	-

	x	x	x	x					x						x		
	x	x	x	x					x						x		
	x	x	x	x					x						x		
					x	x	x	x	x					x		x	
					x	x	x	x	x					x		x	
					x	x	x	x	x					x		x	
										x	x	x	x	x		x	x
										x	x	x	x	x		x	x
										x	x	x	x	x		x	x

SKPR(N)

TECHNICAL DATA

Technical specifications on this page and in the tables on the following pages are intended only for rough preselection.

Gear teeth:	SKPR(N) 01 – SKPR(N) 04 Klingelnberg spiral bevel toothing, spur toothing	Permissible gearbox temperature at housing:	-10 °C to +90 °C
Direction of rotation:	The opposite direction when facing C and A	Lubrication:	lubricated for life
Efficiency:	Size 01 $\eta \sim 0,93$ Size 02 $\eta \sim 0,93$ Size 03 $\eta \sim 0,92$ Size 04 $\eta \sim 0,92$	Mounting position:	Please specify when ordering
Life time:	20000 h	Surface protection:	Primer coat RAL 9005 black
		Protection rating:	IP 54





SKPR(N) 01 - SKPR(N) 02

TECHNICAL DATA

The following technical specifications in the table are intended only for rough preselection

SKPR(N)			01													
Ratio	i		12	15	20	25	30	35	40	45	50	63	70	80	100	
Max. acceleration torque (max. 1000 cycles per hour)	T_{2bzul}	Nm	100	100	100	100	100	100	100	100	100	100	100	80	80	
Nominal torque on output shaft (at n_{1Nzul})	T_{2Nzul}	Nm	70	70	70	70	70	70	70	70	70	70	70	45	45	
Emergency stop torque (permissible 1000 times during gearbox life time)	$T_{2Notzul}$	Nm	250	250	250	250	250	250	200	180	150	215	215	200	200	
Permissible average input speed (with T_{2Nzul} and 20 °C ambient temperature)	n_{1mzul}	min ⁻¹	4000													
Max. input speed	$n_{1maxzul}$	min ⁻¹	7500													
Max. backlash*	j	arcmin	standard ≤ 5 / reduced ≤ 3													
Torsional rigidity [▲]	C	Nm/arcmin	8,8													
Max. radial load** (with reference to shaft centre on output shaft)	F_{2rzul}	N	3800													
Max. axial load** (with reference to shaft centre on output shaft)	F_{2azul}	N	3200													
Weight	m	kg	approx. 6,2													
Running noise (with $n_1 = 3000$ min ⁻¹ without load)	L_{PA}	dB(A)	approx. 68 / distance of 1 m													
Inertia (with reference to input)	Ø d 9	J_1	kgcm ²	0,67	0,66	0,55	0,51	0,47	0,45	0,44	0,43	0,42	0,43	0,42	0,44	0,42
	Ø d 11	J_1	kgcm ²	0,67	0,66	0,55	0,51	0,47	0,45	0,44	0,43	0,42	0,43	0,42	0,44	0,42
	Ø d 14	J_1	kgcm ²	0,67	0,66	0,55	0,51	0,47	0,45	0,44	0,43	0,42	0,43	0,42	0,44	0,42

SKPR(N)			02													
Ratio	i		12	15	20	25	30	35	40	45	50	63	70	80	100	
Max. acceleration torque (max. 1000 cycles per hour)	T_{2bzul}	Nm	250	250	250	250	250	250	250	250	240	250	250	200	200	
Nominal torque on output shaft (at n_{1Nzul})	T_{2Nzul}	Nm	170	170	170	170	170	170	170	170	170	170	170	110	110	
Emergency stop torque (permissible 1000 times during gearbox life time)	$T_{2Notzul}$	Nm	620	620	620	620	480	550	470	470	320	550	445	500	500	
Permissible average input speed (with T_{2Nzul} and 20 °C ambient temperature)	n_{1mzul}	min ⁻¹	4000													
Max. input speed	$n_{1maxzul}$	min ⁻¹	7500													
Max. backlash*	j	arcmin	standard ≤ 5 / reduced ≤ 3													
Torsional rigidity [▲]	C	Nm/arcmin	23													
Max. radial load** (with reference to shaft centre on output shaft)	F_{2rzul}	N	6000													
Max. axial load** (with reference to shaft centre on output shaft)	F_{2azul}	N	5400													
Weight	m	kg	approx. 13,4													
Running noise (with $n_1 = 3000$ min ⁻¹ without load)	L_{PA}	dB(A)	approx. / distance of 1 m													
Inertia (with reference to input)	Ø d 9	J_1	kgcm ²	1,72	1,70	1,40	1,29	1,23	1,20	1,16	1,15	1,14	1,15	1,14	1,16	1,14
	Ø d 11	J_1	kgcm ²	1,72	1,70	1,40	1,29	1,23	1,20	1,16	1,15	1,14	1,15	1,14	1,16	1,14
	Ø d 14	J_1	kgcm ²	1,72	1,70	1,40	1,29	1,23	1,20	1,16	1,15	1,14	1,15	1,14	1,16	1,14
	Ø d 19	J_1	kgcm ²	1,72	1,70	1,40	1,29	1,23	1,20	1,16	1,15	1,14	1,15	1,14	1,16	1,14

[▲]with reference to output

* measured with 2 % nominal torque on output shaft

**charge centre of output shaft at output speed 250 min⁻¹. Please contact us for combined load applications

SKPR(N) 03

TECHNICAL DATA

SKPR(N)			03													
Ratio	i		12	15	20	25	30	35	40	45	50	63	70	80	100	
Max. acceleration torque (max. 1000 cycles per hour)	T_{Zbzul}	Nm	500	500	500	500	500	500	500	500	500	500	500	400	400	
Nominal torque on output shaft (at n_{1Nzul})	T_{ZNzul}	Nm	360	360	360	360	360	360	360	360	360	360	360	220	220	
Emergency stop torque (permissible 1000 times during gearbox life time)	$T_{ZNotzul}$	Nm	1250	1250	1250	1250	910	1100	910	800	800	1100	1250	1000	1000	
Permissible average input speed (with T_{ZNzul} and 20 °C ambient temperature)	n_{1mzul}	min ⁻¹	4000													
Max. input speed	$n_{1maxzul}$	min ⁻¹	6500													
Max. backlash*	j	arcmin	standard ≤ 5 / reduced ≤ 3													
Torsional rigidity [▲]	C	Nm/arcmin	47													
Max. radial load** (with reference to shaft centre on output shaft)	F_{Zrzul}	N	9000													
Max. axial load** (with reference to shaft centre on output shaft)	F_{Zazul}	N	9400													
Weight	m	kg	approx. 27,5													
Running noise (with $n_1 = 3000$ min ⁻¹ without load)	L_{PA}	dB(A)	approx. 70 / distance of 1 m													
Inertia (with reference to input)	Ø d 11	J_1	kgcm ²	7,01	6,93	5,62	5,05	4,75	4,57	4,48	4,36	4,31	4,35	4,30	4,45	4,30
	Ø d 14	J_1	kgcm ²	7,01	6,93	5,62	5,05	4,75	4,57	4,48	4,36	4,31	4,35	4,30	4,45	4,30
	Ø d 19	J_1	kgcm ²	7,01	6,93	5,62	5,05	4,75	4,57	4,48	4,36	4,31	4,35	4,30	4,45	4,30
	Ø d 24	J_1	kgcm ²	7,01	6,93	5,62	5,05	4,75	4,57	4,48	4,36	4,31	4,35	4,30	4,45	4,30
	Ø d 28	J_1	kgcm ²	7,01	6,93	5,62	5,05	4,75	4,57	4,48	4,36	4,31	4,35	4,30	4,45	4,30

[▲]with reference to output

* measured with 2 % nominal torque on output shaft

**charge centre of output shaft at output speed 250 min⁻¹. Please contact us for combined load applications



SKPR(N) 04

TECHNICAL DATA

The following technical specifications in the table are intended only for rough preselection

SKPR(N)			04													
Ratio	i		12	15	20	25	30	35	40	45	50	63	70	80	100	
Max. acceleration torque (max. 1000 cycles per hour)	T_{2bzul}	Nm	925	925	925	925	680	950	680	675	675	940	940	880	880	
Nominal torque on output shaft (at n_{1Nzul})	T_{2Nzul}	Nm	550	550	550	550	500	550	500	450	450	550	550	340	340	
Emergency stop torque (permissible 1000 times during gearbox life time)	$T_{2Notzul}$	Nm	1250	1250	1250	1250	910	1270	910	800	800	1260	1260	1800	1800	
Permissible average input speed (with T_{2Nzul} and 20 °C ambient temperature)	n_{1mzul}	min ⁻¹	4000													
Max. input speed	$n_{1maxzul}$	min ⁻¹	6500													
Max. backlash*	j	arcmin	standard ≤ 5 / reduced ≤ 3													
Torsional rigidity [▲]	C	Nm/arcmin	140													
Max. radial load** (with reference to shaft centre on output shaft)	F_{2rzul}	N	14000													
Max. axial load** (with reference to shaft centre on output shaft)	F_{2azul}	N	13500													
Weight	m	kg	approx. 33,5													
Running noise (with $n_1 = 3000$ min ⁻¹ without load)	L_{PA}	dB(A)	approx. 70 / distance of 1 m													
Inertia (with reference to input)	Ø d 11	J_1	kgcm ²	7,40	7,18	5,76	5,14	4,82	4,62	4,50	4,39	4,33	4,37	4,31	4,46	4,30
	Ø d 14	J_1	kgcm ²	7,40	7,18	5,76	5,14	4,82	4,62	4,50	4,39	4,33	4,37	4,31	4,46	4,30
	Ø d 19	J_1	kgcm ²	7,40	7,18	5,76	5,14	4,82	4,62	4,50	4,39	4,33	4,37	4,31	4,46	4,30
	Ø d 24	J_1	kgcm ²	7,40	7,18	5,76	5,14	4,82	4,62	4,50	4,39	4,33	4,37	4,31	4,46	4,30
	Ø d 28	J_1	kgcm ²	7,40	7,18	5,76	5,14	4,82	4,62	4,50	4,39	4,33	4,37	4,31	4,46	4,30

[▲]with reference to output

* measured with 2 % nominal torque on output shaft

**charge centre of output shaft at output speed 250 min⁻¹. Please contact us for combined load applications

SKPR(N) 01 - SKPR(N) 04

DIMENSIONS

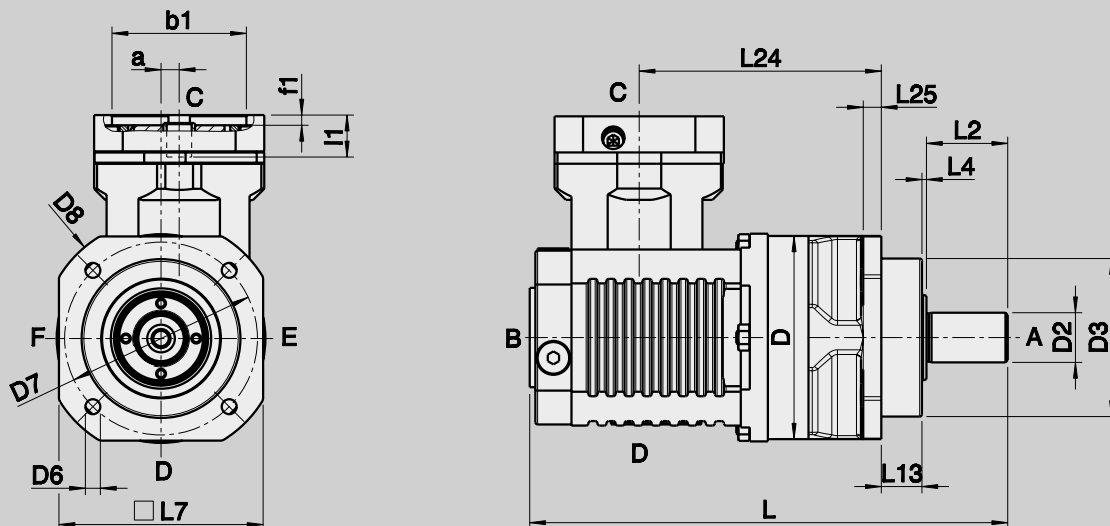

Design SKPR(N), output shaft with keyway DIN 6885

d	x	l1	Size	D2	D3	D6	D7	D8	D	a	L	L2
G7				k6	g6							
9	x	20										
11	x	23	01	22	70	6,6	85	105	90	8	211,8	36
14	x	30										
9	x	20										
11	x	23	02	32	90	9	120	140	120	12	274,5	58
14	x	30										
19	x	40										
11	x	23										
14	x	30	03	40	130	11	165	190	155	18	346	82
19	x	40										
24	x	50										
28	x	60										
11	x	23										
14	x	30	04	55	160	13	215	245	185	18	375,5	82
19	x	40										
24	x	50										
28	x	60										



d	x	l1	Größe	L4	L7	L13	L24	L25
G7								
9	x	20	01	2	90	18	107,3	8
11	x	23						
14	x	30						
9	x	20	02	2	120	28	132,5	10
11	x	23						
14	x	30						
19	x	40						
11	x	23	03	2	155	28	167	12
14	x	30						
19	x	40						
24	x	50						
28	x	60						
11	x	23	04	3	180	27	196,5	15
14	x	30						
19	x	40						
24	x	50						
28	x	60						

SKPR(N) 01 - SKPR(N) 04
 DIMENSIONS MOTOR MOUNTING

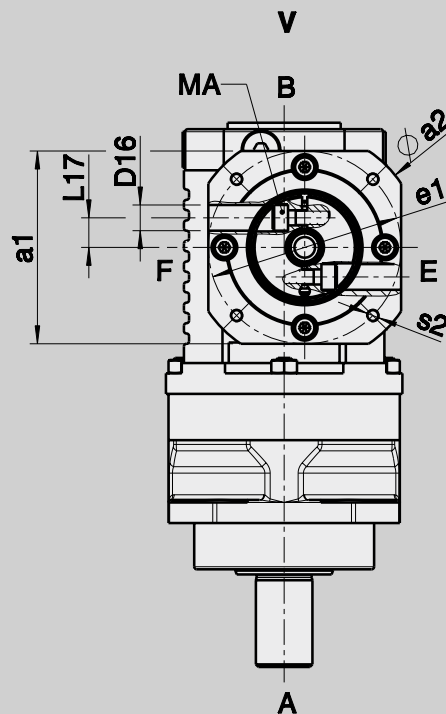
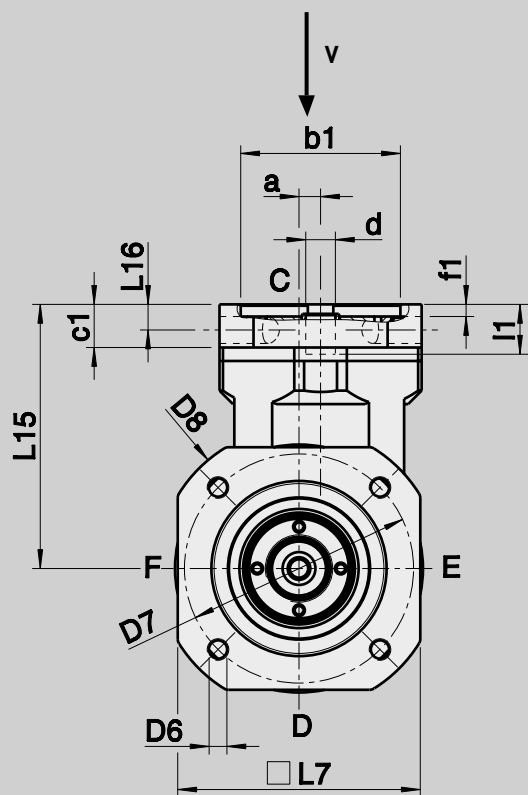

Gearbox dimensions

d	x	l1	Size	l15	l16	l17	c1	f1	D16	Screw type	MA
											(Nm)
9	x	20	01	98.5	9.5	10	16	4.5	8.5	M6 / 12,9	18
11	x	23		98.5	9.5	10	16	4.5	8.5	M6 / 12,9	18
14	x	30		98.5	9.5	10	16	4.5	8.5	M6 / 12,9	18
9	x	20	02	125	13	12.5	22	5	10	M6 / 12,9	18
11	x	23		125	13	12.5	22	5	10	M6 / 12,9	18
14	x	30		125	13	12.5	22	5	10	M6 / 12,9	18
19	x	40		125	13	12.5	22	5	10	M6 / 12,9	18
11	x	23	03 / 04	145	15	16.5	25	5	14	M6 / 12,9	18
14	x	30		145	15	16.5	25	5	14	M6 / 12,9	18
19	x	40		145	15	16.5	25	5	14	M8 / 12,9	39
24	x	50		145	15	16.5	25	5	14	M8 / 12,9	43
28	x	60		145	15	16.5	25	5	14	M8 / 12,9	43



Motor dimensions

a1		75	75	75	90	95	95	95	95	115	125	125	125	125	130	140	140	200
a2		90	90	100	120	120	120	120	120	140	140	140	140	140	160	160	190	250
b1	G8	50	60	70	80	50	60	70	80	95	60	70	80	95	110	110	130	180
e1		70	75	85	100	70	75	85	100	115	75	85	100	115	130	130	165	215
s2		M5 x10	M5 x10	M6 x12	M6 x12	M5 x10	M5 x10	M6 x12	M6 x12	M8 x16	M5 x10	M6 x12	M6 x12	M8 x16	M8 x16	M8 x16	M10 x20	M12 x24
		-	∅ 5,5	∅ 7,0	∅ 7,0	-	∅ 5,5	∅ 7,0	∅ 7,0	∅ 9,0	-	-	-	∅ 9,0	∅ 9,0	∅ 9,0	∅ 11,0	-

	x	x	x	x					x						x		
	x	x	x	x					x						x		
	x	x	x	x					x						x		
					x	x	x	x	x					x		x	
					x	x	x	x	x					x		x	
					x	x	x	x	x					x		x	
										x	x	x	x	x		x	x
										x	x	x	x	x		x	x
										x	x	x	x	x		x	x

SKPG

TECHNICAL DATA

Technical specifications on this page and in the tables on the following pages are intended only for rough preselection.

Gear teeth:	SKPG 01 – SKPG 04 Klingelnberg spiral bevel toothing, spur toothing	Permissible gearbox temperature at housing:	-10 °C to +90 °C
Direction of rotation:	The opposite direction when facing C and A	Lubrication:	lubricated for life
Efficiency:	Size 01 $\eta \sim 0,93$ Size 02 $\eta \sim 0,93$ Size 03 $\eta \sim 0,92$ Size 04 $\eta \sim 0,92$	Mounting position:	Please specify when ordering
Life time:	20000 h	Surface protection:	Primer coat RAL 9005 black
		Protection rating:	IP 54





SKPG 01 - SKPG 02

TECHNICAL DATA

The following technical specifications in the table are intended only for rough preselection

SKPG			01													
Ratio	i		12	15	20	25	30	35	40	45	50	63	70	80	100	
Max. acceleration torque (max. 1000 cycles per hour)	T_{2bzul}	Nm	100	100	100	100	100	100	100	100	100	100	100	80	80	
Nominal torque on output shaft (at n_{1Nzul})	T_{2Nzul}	Nm	70	70	70	70	70	70	70	70	70	70	70	45	45	
Emergency stop torque (permissible 1000 times during gearbox life time)	$T_{2Notzul}$	Nm	250	250	250	250	250	250	200	180	150	215	215	200	200	
Permissible average input speed (with T_{2Nzul} and 20 °C ambient temperature)	n_{1mzul}	min ⁻¹	4000													
Max. input speed	$n_{1maxzul}$	min ⁻¹	7500													
Max. backlash*	j	arcmin	standard ≤ 5 / reduced ≤ 3													
Torsional rigidity [▲]	C	Nm/arcmin	30													
Max. radial load** (with reference to shaft centre on output shaft)	F_{2rzul}	N	2500													
Max. axial load** (with reference to shaft centre on output shaft)	F_{2azul}	N	3600													
Weight	m	kg	approx. 5,8													
Running noise (with $n_1 = 3000$ min ⁻¹ without load)	L_{PA}	dB(A)	approx. / distance of 1 m													
Inertia (with reference to input)	Ø d 9	J_1	kgcm ²	0,69	0,67	0,55	0,49	0,47	0,45	0,44	0,43	0,42	0,43	0,42	0,44	0,42
	Ø d 11	J_1	kgcm ²	0,69	0,67	0,55	0,49	0,47	0,45	0,44	0,43	0,42	0,43	0,42	0,44	0,42
	Ø d 14	J_1	kgcm ²	0,69	0,67	0,55	0,49	0,47	0,45	0,44	0,43	0,42	0,43	0,42	0,44	0,42

SKPG			02													
Ratio	i		12	15	20	25	30	35	40	45	50	63	70	80	100	
Max. acceleration torque (max. 1000 cycles per hour)	T_{2bzul}	Nm	250	250	250	250	250	250	250	250	240	250	250	200	200	
Nominal torque on output shaft (at n_{1Nzul})	T_{2Nzul}	Nm	170	170	170	170	170	170	170	170	170	170	170	110	110	
Emergency stop torque (permissible 1000 times during gearbox life time)	$T_{2Notzul}$	Nm	620	620	620	620	480	550	470	470	320	550	445	500	500	
Permissible average input speed (with T_{2Nzul} and 20 °C ambient temperature)	n_{1mzul}	min ⁻¹	4000													
Max. input speed	$n_{1maxzul}$	min ⁻¹	7500													
Max. backlash*	j	arcmin	standard ≤ 5 / reduced ≤ 3													
Torsional rigidity [▲]	C	Nm/arcmin	80													
Max. radial load** (with reference to shaft centre on output shaft)	F_{2rzul}	N	3100													
Max. axial load** (with reference to shaft centre on output shaft)	F_{2azul}	N	4200													
Weight	m	kg	approx. 11,5													
Running noise (with $n_1 = 3000$ min ⁻¹ without load)	L_{PA}	dB(A)	approx. / distance of 1 m													
Inertia (with reference to input)	Ø d 9	J_1	kgcm ²	1,78	1,73	1,42	1,31	1,24	1,20	1,17	1,16	1,14	1,15	1,16	1,14	1,14
	Ø d 11	J_1	kgcm ²	1,78	1,73	1,42	1,31	1,24	1,20	1,17	1,16	1,14	1,15	1,16	1,14	1,14
	Ø d 14	J_1	kgcm ²	1,78	1,73	1,42	1,31	1,24	1,20	1,17	1,16	1,14	1,15	1,16	1,14	1,14
	Ø d 19	J_1	kgcm ²	1,78	1,73	1,42	1,31	1,24	1,20	1,17	1,16	1,14	1,15	1,16	1,14	1,14

[▲]with reference to output

* measured with 2 % nominal torque on output shaft

**charge centre of output shaft at output speed 250 min⁻¹. Please contact us for combined load applications

SKPG 03

TECHNICAL DATA

SKPG			03													
Ratio	i		12	15	20	25	30	35	40	45	50	63	70	80	100	
Max. acceleration torque (max. 1000 cycles per hour)	T_{Zbzul}	Nm	500	500	500	500	500	500	500	500	500	500	500	400	400	
Nominal torque on output shaft (at n_{1Nzul})	T_{ZNzul}	Nm	360	360	360	360	360	360	360	360	360	360	360	220	220	
Emergency stop torque (permissible 1000 times during gearbox life time)	$T_{ZNotzul}$	Nm	1250	1250	1250	1250	910	1100	910	800	800	1100	1250	1000	1000	
Permissible average input speed (with T_{ZNzul} and 20 °C ambient temperature)	n_{1mzul}	min ⁻¹	4000													
Max. input speed	$n_{1maxzul}$	min ⁻¹	6500													
Max. backlash*	j	arcmin	standard ≤ 5 / reduced ≤ 3													
Torsional rigidity [▲]	C	Nm/arcmin	165													
Max. radial load** (with reference to shaft centre on output shaft)	F_{Zrzul}	N	10500													
Max. axial load** (with reference to shaft centre on output shaft)	F_{Zazul}	N	8000													
Weight	m	kg	approx. 28,5													
Running noise (with $n_1 = 3000$ min ⁻¹ without load)	L_{PA}	dB(A)	approx. / distance of 1 m													
Inertia (with reference to input)	Ø d 11	J_1	kgcm ²	7,17	7,04	5,68	5,09	4,78	4,59	4,46	4,37	4,32	4,36	4,31	4,46	4,30
	Ø d 14	J_1	kgcm ²	7,17	7,04	5,68	5,09	4,78	4,59	4,46	4,37	4,32	4,36	4,31	4,46	4,30
	Ø d 19	J_1	kgcm ²	7,17	7,04	5,68	5,09	4,78	4,59	4,46	4,37	4,32	4,36	4,31	4,46	4,30
	Ø d 24	J_1	kgcm ²	7,17	7,04	5,68	5,09	4,78	4,59	4,46	4,37	4,32	4,36	4,31	4,46	4,30
	Ø d 28	J_1	kgcm ²	7,17	7,04	5,68	5,09	4,78	4,59	4,46	4,37	4,32	4,36	4,31	4,46	4,30

[▲]with reference to output

* measured with 2 % nominal torque on output shaft

**charge centre of output shaft at output speed 250 min⁻¹. Please contact us for combined load applications



SKPG 04

TECHNICAL DATA

The following technical specifications in the table are intended only for rough preselection

SKPG			04													
Ratio	i		12	15	20	25	30	35	40	45	50	63	70	80	100	
Max. acceleration torque (max. 1000 cycles per hour)	T_{2bzul}	Nm	925	925	925	925	680	950	680	675	675	940	940	880	880	
Nominal torque on output shaft (at n_{1Nzul})	T_{2Nzul}	Nm	550	550	550	550	500	550	500	450	450	550	550	340	340	
Emergency stop torque (permissible 1000 times during gearbox life time)	$T_{2Notzul}$	Nm	1250	1250	1250	1250	910	1270	910	800	800	1260	1260	1800	1800	
Permissible average input speed (with T_{2Nzul} and 20 °C ambient temperature)	n_{1mzul}	min ⁻¹	4000													
Max. input speed	$n_{1maxzul}$	min ⁻¹	6500													
Max. backlash*	j	arcmin	standard ≤ 5 / reduced ≤ 3													
Torsional rigidity [▲]	C	Nm/arcmin	185													
Max. radial load** (with reference to shaft centre on output shaft)	F_{2rzul}	N	18070													
Max. axial load** (with reference to shaft centre on output shaft)	F_{2azul}	N	9100													
Weight	m	kg	approx. 31,5													
Running noise (with $n_1 = 3000$ min ⁻¹ without load)	L_{PA}	dB(A)	approx. / distance of 1 m													
Inertia (with reference to input)	Ø d 11	J_1	kgcm ²	7,77	7,04	5,68	5,09	4,78	4,59	4,44	4,38	4,32	4,36	4,31	4,46	4,30
	Ø d 14	J_1	kgcm ²	7,77	7,04	5,68	5,09	4,78	4,59	4,44	4,38	4,32	4,36	4,31	4,46	4,30
	Ø d 19	J_1	kgcm ²	7,77	7,04	5,68	5,09	4,78	4,59	4,44	4,38	4,32	4,36	4,31	4,46	4,30
	Ø d 24	J_1	kgcm ²	7,77	7,04	5,68	5,09	4,78	4,59	4,44	4,38	4,32	4,36	4,31	4,46	4,30
	Ø d 28	J_1	kgcm ²	7,77	7,04	5,68	5,09	4,78	4,59	4,44	4,38	4,32	4,36	4,31	4,46	4,30

[▲]with reference to output

* measured with 2 % nominal torque on output shaft

**charge centre of output shaft at output speed 250 min⁻¹. Please contact us for combined load applications

SKPG 01 - SKPG 04

DIMENSIONS

W: SKPG 01

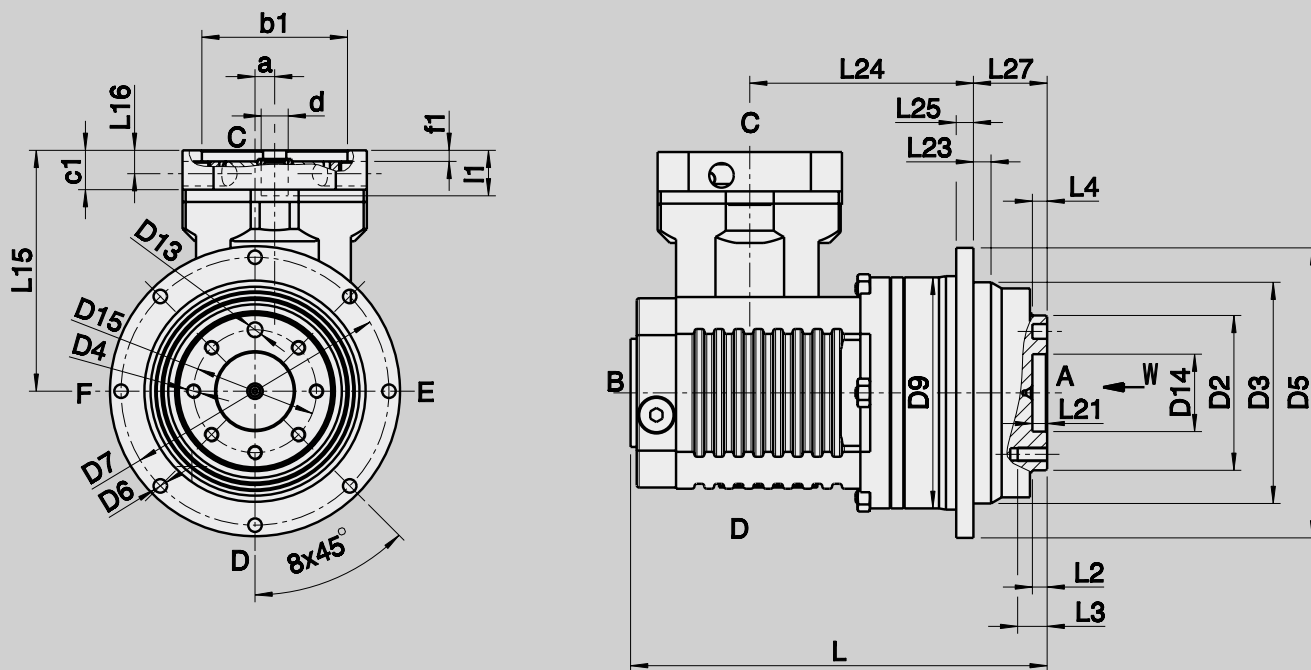

F7: Possible shaft diameters x length

d	x	l1	Size	D2	D3	D4	D5	D6	D7	D9	D13	D14	D15
G7				h7	h6						H7	H7	
9	x	20											
11	x	23	01	63	90	M6	118	5,5	109	95	6	31,5	50
14	x	30											
9	x	20											
11	x	23	02	80	110	M6	145	5,5	135	120	6	40	63
14	x	30											
19	x	40											
11	x	23	03	100	140	M8	179	6,6	168	152	8	50	80
14	x	30											
19	x	40											
24	x	50											
28	x	60											
11	x	23	04	130	170	M10	215	8,5	200	185	10	65	100
14	x	30											
19	x	40											
24	x	50											
28	x	60											



W: SKPG 02

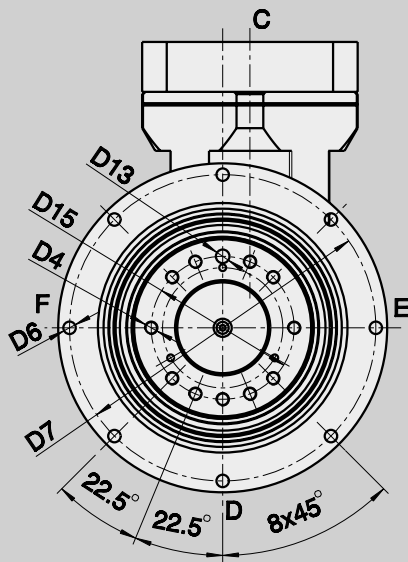

W: SKPG 03/04

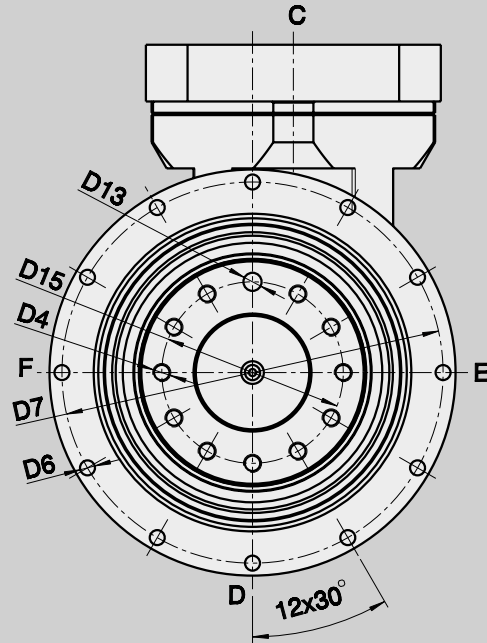

d	x	l1	Size	a	L	L3	L4	L21	L23	L24	L25	L27
G7												
9	x	20										
11	x	23	01	8	169,5	12	6	6	7	91	7	30
14	x	30										
9	x	20										
11	x	23	02	12	189	12	7	6,5	10	106	8	29
14	x	30										
19	x	40										
1	x	23										
14	x	30										
19	x	40	03	18	248	16	7	6,5	12	143	10	38
24	x	50										
28	x	60										
11	x	23										
14	x	30										
19	x	40	04	18	260	20	10	8	12	148	12	45
24	x	50										
28	x	60										

SKPG 01 - SKPG 04

DIMENSIONS MOTOR MOUNTING

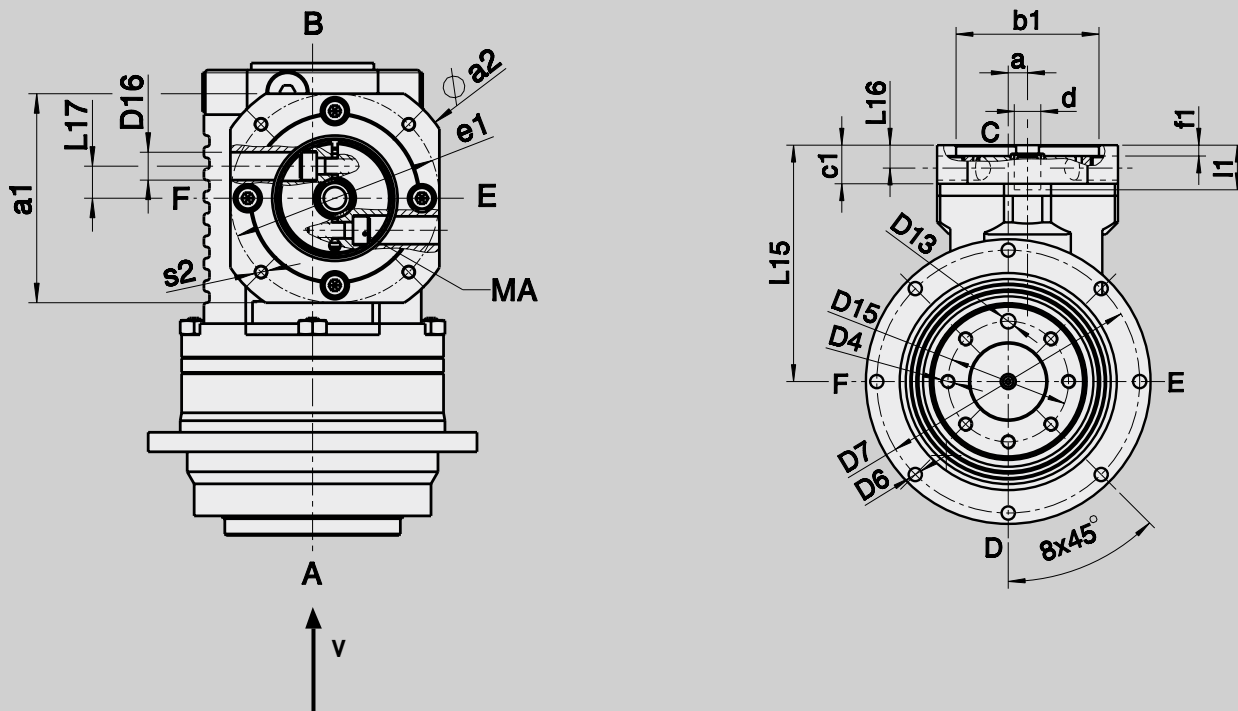

Gearbox dimensions

d	x	l1	Size	L15	L16	L17	c1	f1	D16	Screw type	MA
G7											
9	x	20	01	98,5	9,5	10	16	4,5	8,5	M6 / 12,9	18
11	x	23		98,5	9,5	10	16	4,5	8,5	M6 / 12,9	18
14	x	30		98,5	9,5	10	16	4,5	8,5	M6 / 12,9	18
9	x	20	02	125	13	12,5	22	5	10	M6 / 12,9	18
11	x	23		125	13	12,5	22	5	10	M6 / 12,9	18
14	x	30		125	13	12,5	22	5	10	M6 / 12,9	18
19	x	40		125	13	12,5	22	5	10	M6 / 12,9	18
11	x	23	03 / 04	145	15	16,5	25	5	14	M6 / 12,9	18
14	x	30		145	15	16,5	25	5	14	M6 / 12,9	18
19	x	40		145	15	16,5	25	5	14	M8 / 12,9	39
24	x	50		145	15	16,5	25	5	14	M8 / 12,9	43
28	x	60		145	15	16,5	25	5	14	M8 / 12,9	43



Motor dimensions

a1		75	75	75	90	95	95	95	95	115	125	125	125	125	130	140	140	200
a2		90	90	100	120	120	120	120	120	140	140	140	140	140	160	160	190	250
b1	G8	50	60	70	80	50	60	70	80	95	60	70	80	95	110	110	130	180
e1		70	75	85	100	70	75	85	100	115	75	85	100	115	130	130	165	215
s2		M5 x10	M5 x10	M6 x12	M6 x12	M5 x10	M5 x10	M6 x12	M6 x12	M8 x16	M5 x10	M6 x12	M6 x12	M8 x16	M8 x16	M8 x16	M10 x20	M12 x24
		-	∅ 5,5	∅ 7,0	∅ 7,0	-	∅ 5,5	∅ 7,0	∅ 7,0	∅ 9,0	-	-	-	∅ 9,0	∅ 9,0	∅ 9,0	∅ 11,0	-

	x	x	x	x					x							x		
	x	x	x	x					x							x		
	x	x	x	x					x							x		
					x	x	x	x	x						x		x	
					x	x	x	x	x						x		x	
					x	x	x	x	x						x		x	
										x	x	x	x	x			x	x
										x	x	x	x	x			x	x
										x	x	x	x	x			x	x

SK(N), SKH, SKPR(N), SKPG
MOUNTING POSITION

Mounting position:

Side view

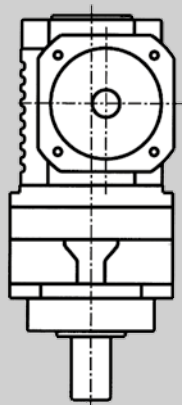

A

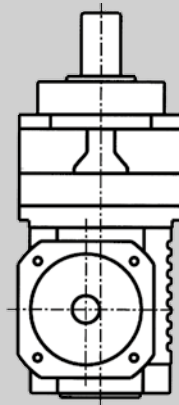

B

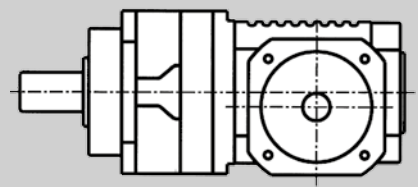

C

Mounting position:

(underside)

Mounting position A + C + D + E + F

The gearboxes have on the flange side B on all faces threaded plugs.

The breather screw is supplied loose and must be fitted upon installation.

See the following sketch.

Mounting position B

Attention! For mounting position "B" = underside consultation with Vogel Antriebstechnik is necessary.

SK(N), SKH, SKPR(N), SKPG
MOUNTING POSITION



Output Breather assembling:

- 1 = Breather
- 2 = Threaded plug

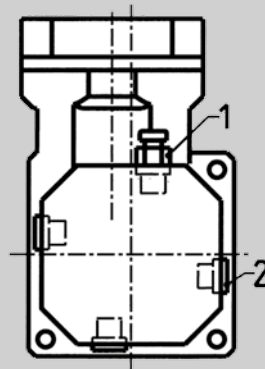

ANGULAR SPIRAL BEVEL GEARBOXES

The basic housing has a cubic shape, guaranteeing symmetrical dimensions. Centring possibilities have been included on all input and output sides. The housing and bearing flanges are made of high-grade grey cast iron, have been machined all-round and have fastening threads $2 \times \varnothing$.

The use of sturdy roller bearings ensures a long service life. The modular system allows a wide range of input and output modifications.

ML		
50	100	200
Page 102	Page 103	Page 103

MH		
50	100	200
Page 108	Page 109	Page 109

MH shrink disc		
50	100	200
Page 112	Page 112	Page 112



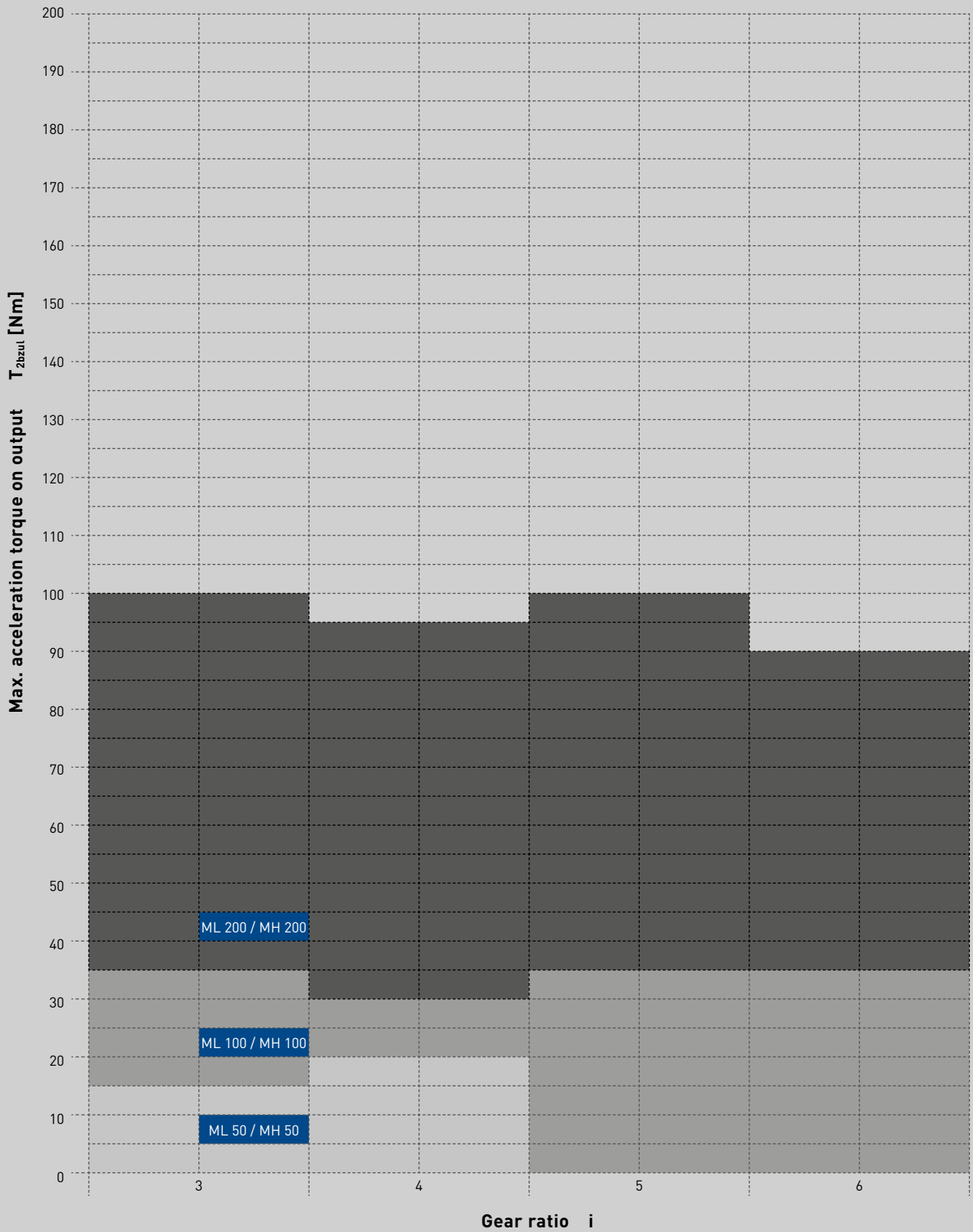

ML

TECHNICAL DATA

Technical specifications on this page and in the tables on the following two pages are intended only for rough preselection.

- Gear teeth: ML 50 Klingenberg spiral bevel toothing
ML 100 – ML 200 Klingenberg spiral bevel toothing ground
- Direction of rotation: The opposite direction when facing C and A
- Efficiency: Size 50 $\eta \sim 0,88 - 0,92$
Size 100 $\eta \sim 0,90 - 0,94$
Size 200 $\eta \sim 0,90 - 0,94$
- Life time: 20000 h
- Permissible gearbox temperature at housing: $-10\text{ °C to }+90\text{ °C}$
- Lubrication: Oil lubrication
- Mounting position: Any, please specify when ordering
- Surface protection: Primer coat RAL 9005 black
- Protection rating: IP 54



ML BA 30. 50				50	
Ratio	i			3	4
Max. acceleration torque (max. 1000 cycles per hour)	T_{2bzul}	Nm		16	18
Nominal torque on output shaft (at n_{1Nzul})	T_{2Nzul}	Nm		12	12
Emergency stop torque (permissible 1000 times during gearbox life time)	$T_{2Notzul}$	Nm		30	30
Permissible average input speed (with T_{2Nzul} and 20 °C ambient temperature)	n_{1mzul}	min ⁻¹		3000	3000
Max. input speed	$n_{1maxzul}$	min ⁻¹		5000	5000
Max. backlash*	j	arcmin		≤ 7	
Torsional rigidity [▲]	C	Nm/arcmin		on request	
Max. radial load** (with reference to shaft centre on output shaft)	F_{2rzul}	N		900	900
Max. axial load** (with reference to shaft centre on output shaft)	F_{2azul}	N		650	650
Weight	m	kg		approx. 1,7	
Running noise (with $n_1 = 3000\text{ min}^{-1}$ without load)	L_{PA}	dB(A)		approx. 75 / distance of 1 m	
Inertia (with reference to input)	Ø d 9	J_1	kgcm ²	0,177	0,151
	Ø d 11	J_1	kgcm ²	0,228	0,202
	Ø d 14	J_1	kgcm ²	0,279	0,253

perm. torques at $n_1 = 1500\text{ min}^{-1}$

**charge centre of output shaft at output speed 250 min^{-1} . Please contact us for combined load applications

[▲]with reference to output

* measured with 2 % nominal torque on output shaft



ML 50 - ML 200

TECHNICAL DATA

The following technical specifications in the table are intended only for rough preselection

ML BA 30. 50				100			
Ratio	i			3	4	5	6
Max. acceleration torque (max. 1000 cycles per hour)	T_{2bzul}	Nm		35	30	35	35
Nominal torque on output shaft (at n_{1Nzul})	T_{2Nzul}	Nm		30	25	30	30
Emergency stop torque (permissible 1000 times during gearbox life time)	$T_{2Notzul}$	Nm		75	62	75	75
Permissible average input speed (with T_{2Nzul} and 20 °C ambient temperature)	n_{1mzul}	min ⁻¹		3000	3000	3000	3000
Max. input speed	$n_{1maxzul}$	min ⁻¹		5000	5000	5000	5000
Max. backlash*	j	arcmin		≤ 4			
Torsional rigidity [▲]	C	Nm/arcmin		on request			
Max. radial load** (with reference to shaft centre on output shaft)	F_{2rzul}	N		1450	1450	1450	1450
Max. axial load** (with reference to shaft centre on output shaft)	F_{2azul}	N		1000	1000	1000	1000
Weight	m	kg		approx. 5			
Running noise (with $n_1 = 3000 \text{ min}^{-1}$ without load)	L_{PA}	dB(A)		approx. 75 / distance of 1 m			
Inertia (with reference to input)	Ø d 9	J_1	kgcm ²	0,80	0,73	0,73	0,69
	Ø d 11	J_1	kgcm ²	0,87	0,80	0,79	0,75
	Ø d 14	J_1	kgcm ²	1,18	0,92	0,92	0,88
	Ø d 19	J_1	kgcm ²	1,47	1,43	1,40	1,36

ML BA 30. 50				200			
Ratio	i			3	4	5	6
Max. acceleration torque (max. 1000 cycles per hour)	T_{2bzul}	Nm		100	95	100	90
Nominal torque on output shaft (at n_{1Nzul})	T_{2Nzul}	Nm		75	75	75	70
Emergency stop torque (permissible 1000 times during gearbox life time)	$T_{2Notzul}$	Nm		187	187	187	175
Permissible average input speed (with T_{2Nzul} and 20 °C ambient temperature)	n_{1mzul}	min ⁻¹		3000	3000	3000	3000
Max. input speed	$n_{1maxzul}$	min ⁻¹		5000	5000	5000	5000
Max. backlash*	j	arcmin		≤ 4			
Torsional rigidity [▲]	C	Nm/arcmin		on request			
Max. radial load** (with reference to shaft centre on output shaft)	F_{2rzul}	N		2200	2200	2200	2200
Max. axial load** (with reference to shaft centre on output shaft)	F_{2azul}	N		1550	1550	1550	1550
Weight	m	kg		approx. 12,5			
Running noise (with $n_1 = 3000 \text{ min}^{-1}$ without load)	L_{PA}	dB(A)		approx. 75 / distance of 1 m			
Inertia (with reference to input)	Ø d 14	J_1	kgcm ²	4,91	4,57	4,41	4,31
	Ø d 19	J_1	kgcm ²	5,40	5,05	5,00	4,90
	Ø d 24	J_1	kgcm ²	6,36	6,02	5,96	5,76
	Ø d 28	J_1	kgcm ²	8,59	8,24	8,18	8,00

perm. torques at $n_1 = 1500 \text{ min}^{-1}$

▲with reference to output
* measured with 2 % nominal torque on output shaft
**charge centre of output shaft at output speed 250 min⁻¹. Please contact us for combined load applications

ML 50 - ML 200

DIMENSIONS

ML 50

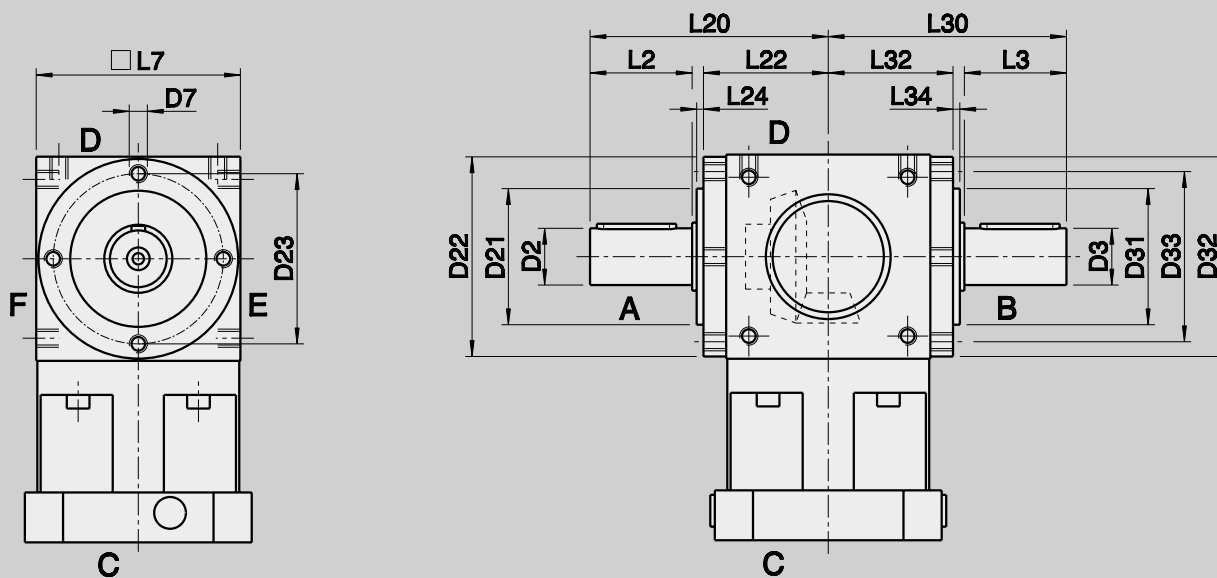

d	x	l1	Size	D2	D3	D7	D21	D22	D23	D31	D32	D33	Key D2 / D3 according to DIN 6885/1
G7				j6	j6		f7			f7			
9	x	20											
11	x	23	50	12	12	M6	44	64,5	54	44	64,5	54	4x4x20
14	x	30											
9	x	20											
11	x	23	100	18	18	M8	60			60			6x6x25
14	x	30											
19	x	40											
11	x	23											
14	x	30											
19	x	40	200	25	25	M10	80			80			8x7x36
24	x	50											
28	x	60											



ML 100 / 200

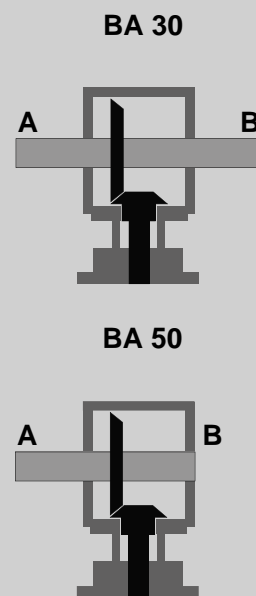
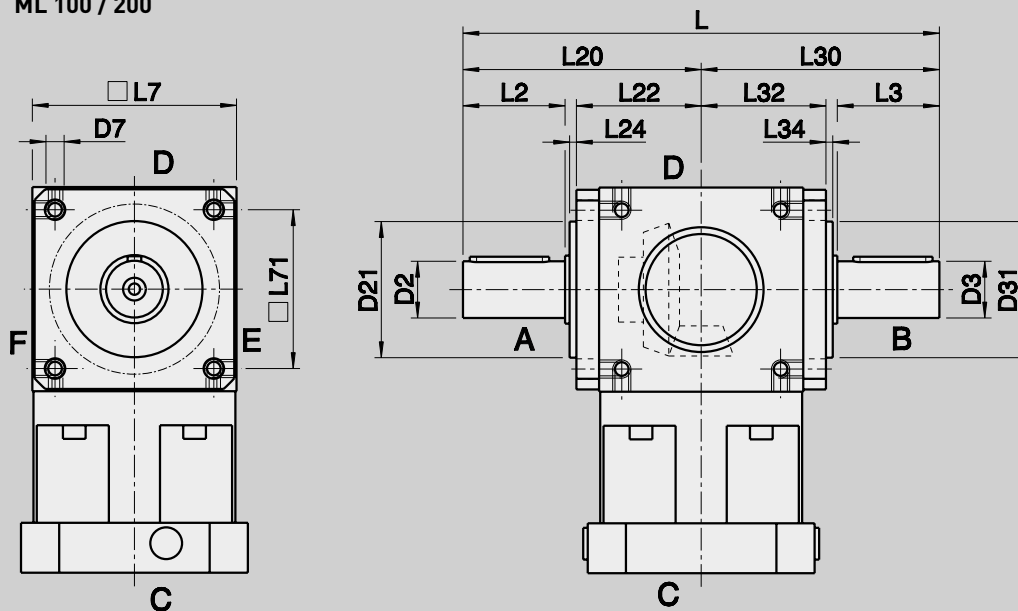

d	x	l1	Size	L	L2	L3	L7	L20	L22	L24	L30	L32	L34	L71
G7														
9	x	20												
11	x	23	50	144	26	26	65	72	42	2	72	42	2	45
14	x	30												
9	x	20												
11	x	23	100	190	35	35	90	95	55	3	95	55	3	70
14	x	30												
19	x	40												
11	x	23												
14	x	30												
19	x	40	200	244	45	45	120	122	72	3	122	72	3	100
24	x	50												
28	x	60												

ML 50 - ML 200

DIMENSIONS MOTOR MOUNTING

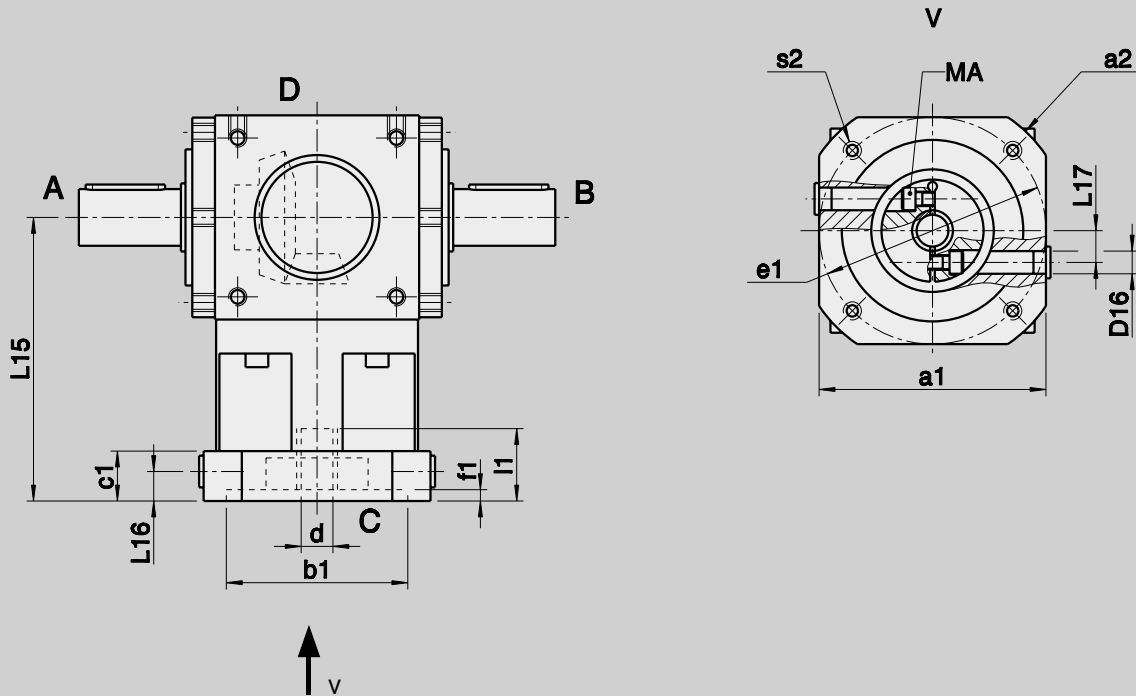

Gearbox dimensions

d	x	l1	Size	L15	L16	L17	c1	f1	D16	Screw type	MA
G7											[Nm]
9	x	20	50	90	9,5	10	16	4,5	8,5	M6 / 12.9	18
11	x	23		90	9,5	10	16	4,5	8,5	M6 / 12.9	18
14	x	30		90	9,5	10	16	4,5	8,5	M6 / 12.9	18
9	x	20	100	125	13	12,5	22	5	10	M6 / 12.9	18
11	x	23		125	13	12,5	22	5	10	M6 / 12.9	18
14	x	30		125	13	12,5	22	5	10	M6 / 12.9	18
19	x	40		125	13	12,5	22	5	10	M6 / 12.9	18
11	x	23	200	145	15	16,5	25	5	14	M6 / 12.9	18
14	x	30		145	15	16,5	25	5	14	M6 / 12.9	18
19	x	40		145	15	16,5	25	5	14	M8 / 12.9	39
24	x	50		145	15	16,5	25	5	14	M8 / 12.9	43
28	x	60		145	15	16,5	25	5	14	M8 / 12.9	43



Motor dimensions

a1		75	90	95	95	115	125	125	130	140
a2		100	120	105	120	140	140	140	160	190
b1	G8	70	80	70	80	95	80	95	110	130
e1		85	100	85	100	115	100	115	130	165
s2		M6	M6	M6	M6	M8	M6	M8	M8	M10
		x12	x12	x12	x12	x16	x12	x16	x16	x20
		∅ 7,0	∅ 7,0	∅ 7,0	∅ 7,0	∅ 9,0	∅ 7,0	∅ 9,0	∅ 9,0	∅ 11,0

	x								
		x				x			
			x		x				x
							x		
								x	
									x
								x	
									x

M H

TECHNICAL DATA

Technical specifications on this page and in the tables on the following two pages are intended only for rough preselection.

- Gear teeth: MH 50 Klingenberg spiral bevel toothing
MH 100 – MH 200 Klingenberg spiral bevel toothing ground
- Direction of rotation: The opposite direction when facing C and A
- Efficiency: Size 50 $\eta \sim 0,88 - 0,92$
Size 100 $\eta \sim 0,90 - 0,94$
Size 200 $\eta \sim 0,90 - 0,94$
- Life time: 20000 h
- Permissible gearbox temperature at housing: -10 °C to $+90\text{ °C}$
- Lubrication: Oil lubrication
- Mounting position: Any, please specify when ordering
- Surface protection: Primer coat RAL 9005 black
- Protection rating: IP 54



MH BA 70			50		
Ratio	i		3	4	
Max. acceleration torque (max. 1000 cycles per hour)	T_{2bzul}	Nm	16	18	
Nominal torque on output shaft (at n_{1Nzul})	T_{2Nzul}	Nm	12	12	
Emergency stop torque (permissible 1000 times during gearbox life time)	$T_{2Notzul}$	Nm	30	30	
Permissible average input speed (with T_{2Nzul} and 20 °C ambient temperature)	n_{1mzul}	min ⁻¹	3000	3000	
Max. input speed	$n_{1maxzul}$	min ⁻¹	5000	5000	
Max. backlash*	j	arcmin	≤ 7		
Torsional rigidity [▲]	C	Nm/arcmin	on request		
Max. radial load** (with reference to shaft centre on output shaft)	F_{2rzul}	N	1300	1300	
Max. axial load** (with reference to shaft centre on output shaft)	F_{2azul}	N	900	900	
Weight	m	kg	approx. 1,7		
Running noise (with $n_1 = 3000\text{ min}^{-1}$ without load)	L_{PA}	dB(A)	approx. 75 / distance of 1 m		
Inertia (with reference to input)	$\varnothing d\ 9$	J_1	kgcm ²	0,186	0,159
	$\varnothing d\ 11$	J_1	kgcm ²	0,239	0,212
	$\varnothing d\ 14$	J_1	kgcm ²	0,293	0,266

perm. torques at $n_1 = 1500\text{ min}^{-1}$

▲with reference to output
* measured with 2 % nominal torque on output shaft
**charge centre of output shaft at output speed 250 min^{-1} . Please contact us for combined load applications



MH 50 - MH 200

TECHNICAL DATA

The following technical specifications in the table are intended only for rough preselection

MH BA 70				100			
Ratio	i		3	4	5	6	
Max. acceleration torque (max. 1000 cycles per hour)	T_{2bzul}	Nm	35	30	35	35	
Nominal torque on output shaft (at n_{1Nzul})	T_{2Nzul}	Nm	30	25	30	30	
Emergency stop torque (permissible 1000 times during gearbox life time)	$T_{2Notzul}$	Nm	75	62	75	75	
Permissible average input speed (with T_{2Nzul} and 20 °C ambient temperature)	n_{1mzul}	min ⁻¹	3000	3000	3000	3000	
Max. input speed	$n_{1maxzul}$	min ⁻¹	5000	5000	5000	5000	
Max. backlash*	j	arcmin	≤ 4				
Torsional rigidity [▲]	C	Nm/arcmin	on request				
Max. radial load** (with reference to shaft centre on output shaft)	F_{2rzul}	N	1900	1900	1900	1900	
Max. axial load** (with reference to shaft centre on output shaft)	F_{2azul}	N	1500	1500	1500	1500	
Weight	m	kg	approx. 5				
Running noise (with $n_1 = 3000$ min ⁻¹ without load)	L_{PA}	dB(A)	approx. 75 / distance of 1 m				
Inertia (with reference to input)	Ø d 9	J_1	kgcm ²	0,88	0,78	0,76	0,71
	Ø d 11	J_1	kgcm ²	0,94	0,84	0,82	0,77
	Ø d 14	J_1	kgcm ²	1,07	0,96	0,95	0,90
	Ø d 19	J_1	kgcm ²	1,55	1,45	1,43	1,38

MH BA 70				200			
Ratio	i		3	4	5	6	
Max. acceleration torque (max. 1000 cycles per hour)	T_{2bzul}	Nm	100	95	100	90	
Nominal torque on output shaft (at n_{1Nzul})	T_{2Nzul}	Nm	75	75	75	70	
Emergency stop torque (permissible 1000 times during gearbox life time)	$T_{2Notzul}$	Nm	187	187	187	175	
Permissible average input speed (with T_{2Nzul} and 20 °C ambient temperature)	n_{1mzul}	min ⁻¹	3000	3000	3000	3000	
Max. input speed	$n_{1maxzul}$	min ⁻¹	5000	5000	5000	5000	
Max. backlash*	j	arcmin	≤ 4				
Torsional rigidity [▲]	C	Nm/arcmin	on request				
Max. radial load** (with reference to shaft centre on output shaft)	F_{2rzul}	N	3000	3000	3000	3000	
Max. axial load** (with reference to shaft centre on output shaft)	F_{2azul}	N	2200	2200	2200	2200	
Weight	m	kg	approx. 12,5				
Running noise (with $n_1 = 3000$ min ⁻¹ without load)	L_{PA}	dB(A)	approx. 75 / distance of 1 m				
Inertia (with reference to input)	Ø d 14	J_1	kgcm ²	5,38	4,83	4,77	4,52
	Ø d 19	J_1	kgcm ²	6,17	5,31	5,25	5,01
	Ø d 24	J_1	kgcm ²	7,33	6,30	6,23	5,98
	Ø d 28	J_1	kgcm ²	9,10	8,57	8,45	8,20

perm. torques at $n_1 = 1500$ min⁻¹

▲with reference to output
* measured with 2 % nominal torque on output shaft
**charge centre of output shaft at output speed 250 min⁻¹. Please contact us for combined load applications

MH 50 - MH 200

DIMENSIONS

MH 50

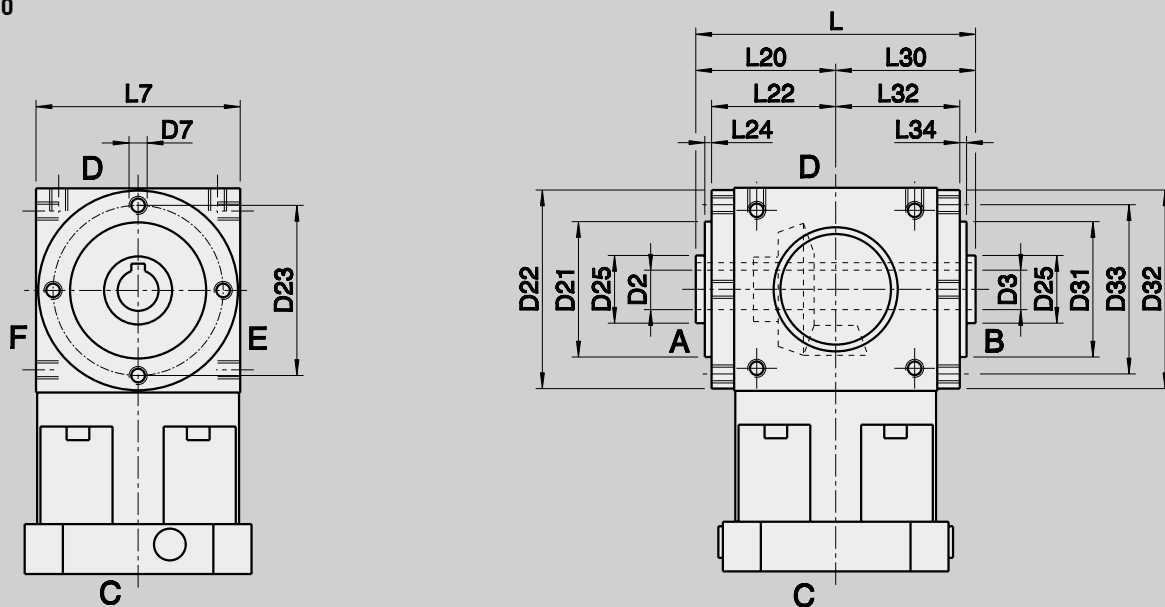

d	x	l1	Size	D2	D3	D7	D21	D22	D23	D25	D31	D32	D33	Keyway according to DIN 6885/1
G7				H7	H7		f7				f7			JS9
9	x	20	50	12	12	M6	44	64,5	54	20	44	64,5	54	4
11	x	23												
14	x	30												
9	x	20	100	18	18	M8	60			30	60			6
11	x	23												
14	x	30												
19	x	40												
11	x	23	200	25	25	M10	80			40	80			8
14	x	30												
19	x	40												
24	x	50												
28	x	60												



MH 100 / 200

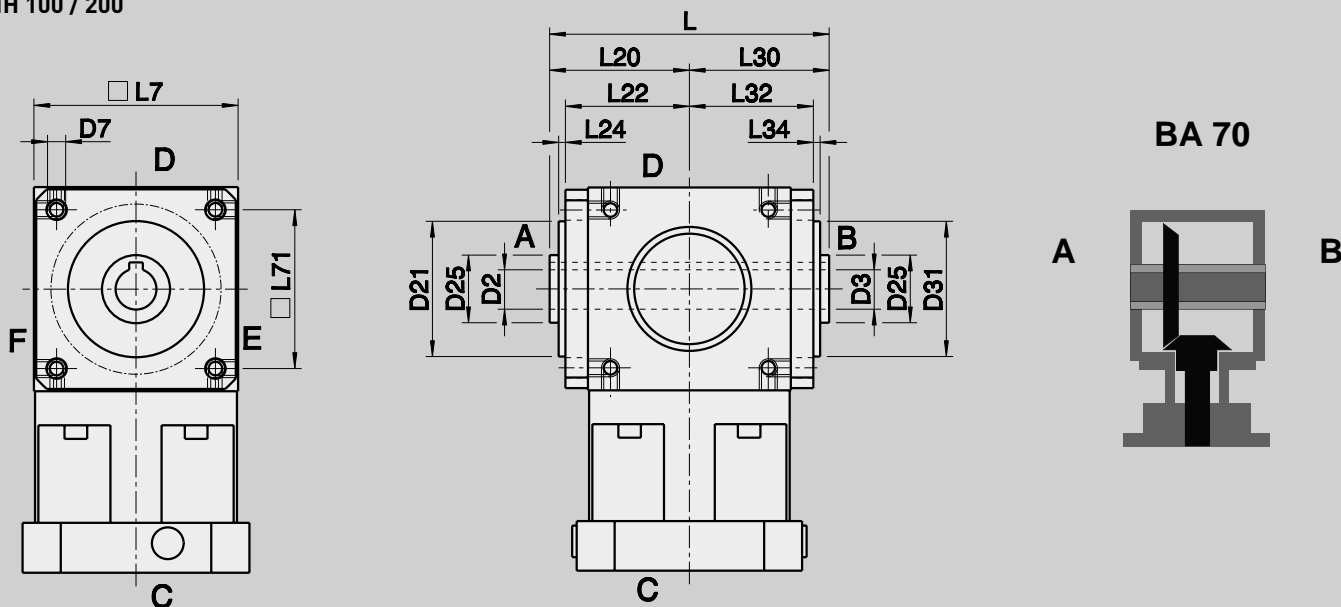

d	x	l1	Size	L	L7	L20	L22	L24	L30	L32	L34	L71
G7												
9	x	20										
11	x	23	50	92	65	46	42	2	46	42	2	45
14	x	30										
9	x	20										
11	x	23	100	124	90	62	55	3	62	55	3	70
14	x	30										
19	x	40										
11	x	23										
14	x	30										
19	x	40	200	170	120	85	77	5	85	77	5	100
24	x	50										
28	x	60										

ADDITIONAL OPTIONS
MH 50 - MH 200 SHRINK DISC
DIMENSIONS

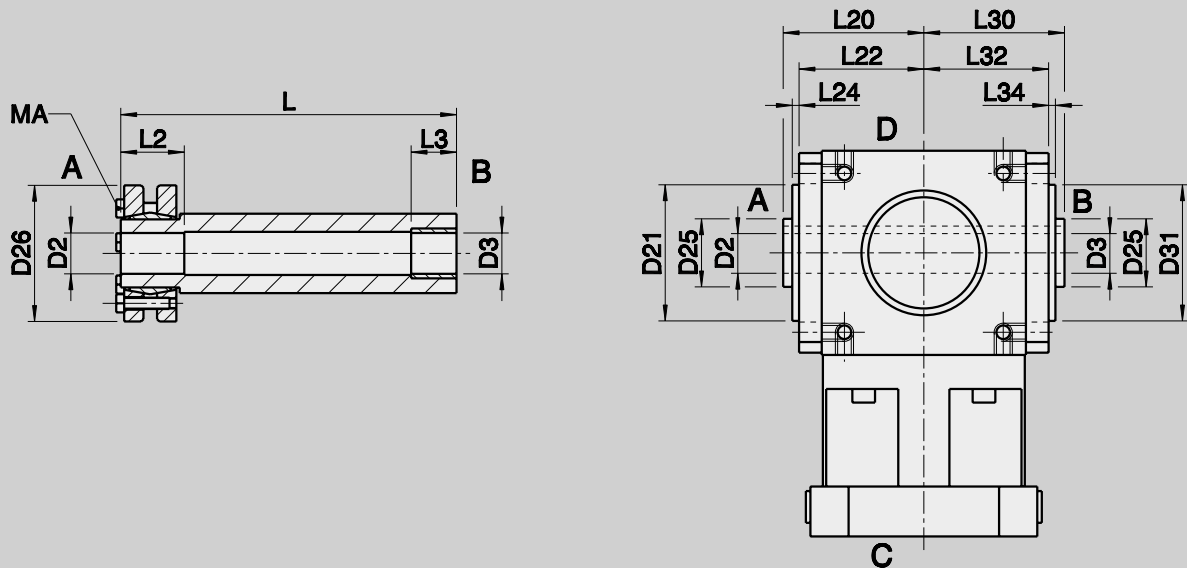

Order details: Side A (or B) with shrink disc
 The required clamping torques MA can be found on the shrink disc.

Size	D2	D3	D26	L	L2	L3	L20	L25	L30	MA
	H7	H7								
50	12	12	41	110	22	12	46	115	46	See separate note!
100	18	18	50	147	21	21	62	148	62	
200	25	25	60	198	24	21	85	199	85	



MH 50 - MH 200

DIMENSIONS MOTOR MOUNTING

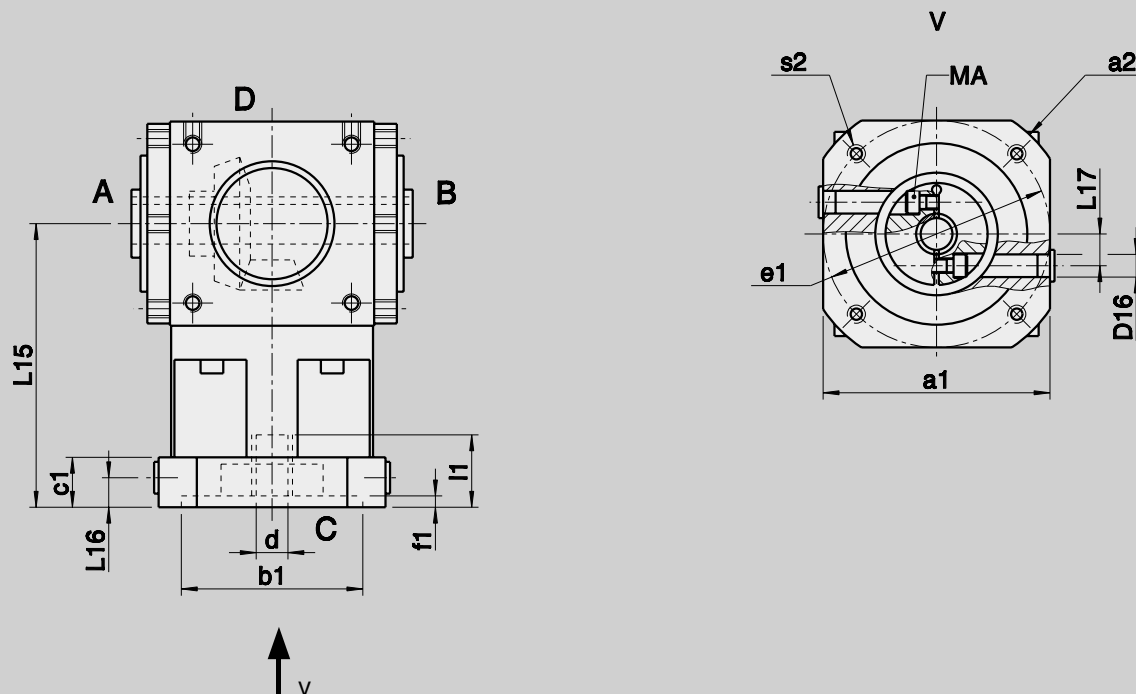

Gearbox dimensions

d	x	l1	Size	L15	L16	L17	c1	f1	D16	Screw type	MA
G7											[Nm]
9	x	20	50	90	9,5	10	16	4,5	8,5	M6 / 12.9	18
11	x	23		90	9,5	10	16	4,5	8,5	M6 / 12.9	18
14	x	30		90	9,5	10	16	4,5	8,5	M6 / 12.9	18
9	x	20	100	125	13	12,5	22	5	10	M6 / 12.9	18
11	x	23		125	13	12,5	22	5	10	M6 / 12.9	18
14	x	30		125	13	12,5	22	5	10	M6 / 12.9	18
19	x	40		125	13	12,5	22	5	10	M6 / 12.9	18
11	x	23	200	145	15	16,5	25	5	14	M6 / 12.9	18
14	x	30		145	15	16,5	25	5	14	M6 / 12.9	18
19	x	40		145	15	16,5	25	5	14	M8 / 12.9	39
24	x	50		145	15	16,5	25	5	14	M8 / 12.9	43
28	x	60		145	15	16,5	25	5	14	M8 / 12.9	43



Motor dimensions

a1		75	90	95	95	115	125	125	130	140
a2		100	120	105	120	140	140	140	160	190
b1	G8	70	80	70	80	95	80	95	110	130
e1		85	100	85	100	115	100	115	130	165
s2		M6	M6	M6	M6	M8	M6	M8	M8	M10
		x12	x12	x12	x12	x16	x12	x16	x16	x20
		∅ 7,0	∅ 7,0	∅ 7,0	∅ 9,0	∅ 9,0	∅ 7,0	∅ 9,0	∅ 9,0	∅ 11,0

	x								
		x				x			
			x		x				x
							x		
								x	
									x
								x	
									x

ANGULAR BEVEL HELICAL GEARBOXES

The gearboxes have a 2-stage design, input is via a spiral bevel stage, output via a helical stage. The housing and bearing flanges are made of high-grade grey cast iron, have been machined all-round and have fastening threads 1,5 x Ø.

Centring possibilities have been included on all input and output flanges. The use of sturdy roller bearings ensures a long service life. The modular system allows a wide range of input and output modifications.

MKS		
1	2	4
Page 118	Page 119	Page 119

MKSH		
1	2	4
Page 124	Page 125	Page 125

MKSHF Output flange		
1	2	4
Page 130	Page 130	Page 130

MKSH Shrink disc		
1	2	4
Page 131	Page 131	Page 131



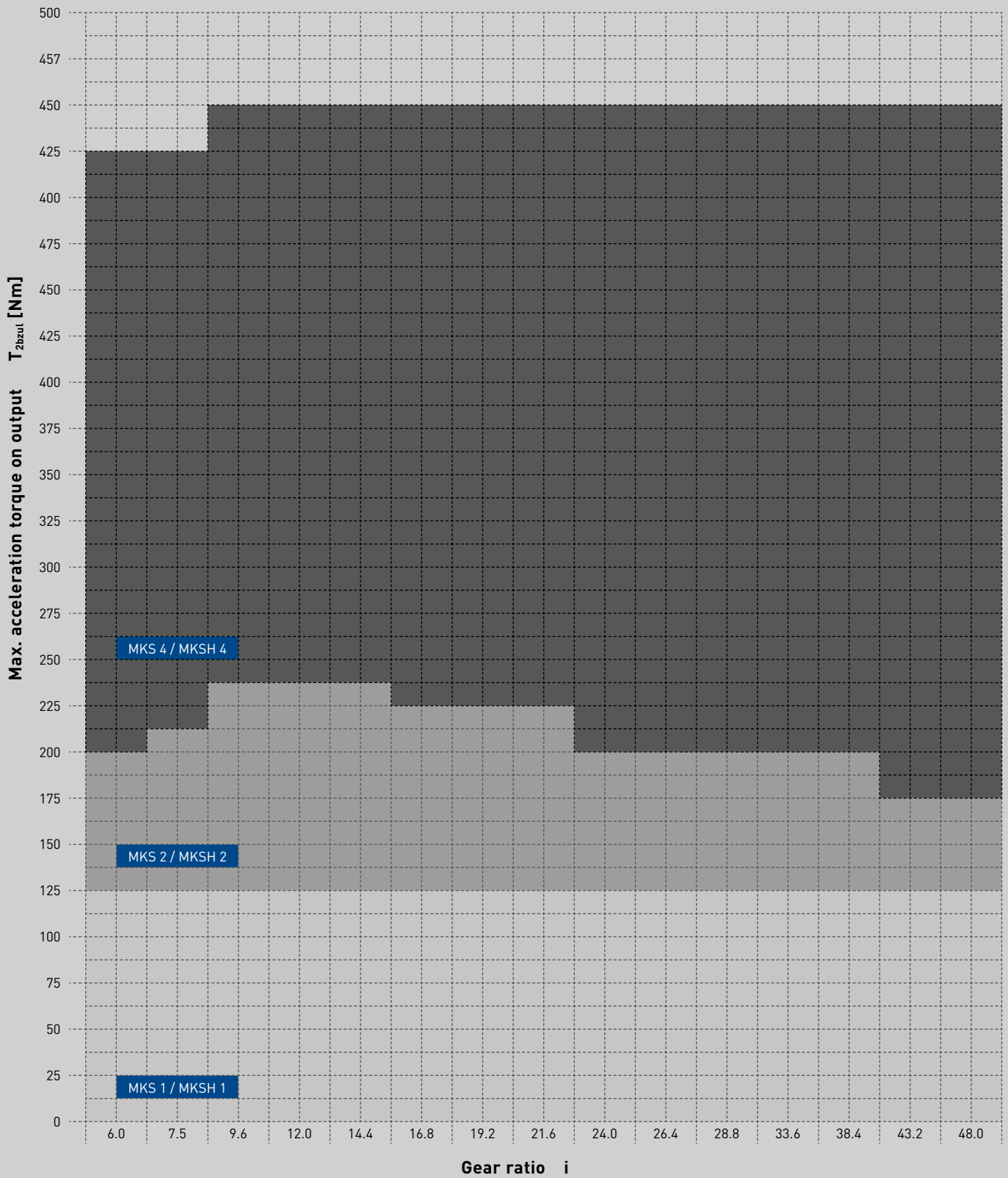

M K S

TECHNICAL DATA

Technical specifications on this page and in the tables on the following two pages are intended only for rough preselection.

- Gear teeth: MKS 1 – MKS 4
Klingelnberg spiral bevel toothing ground
- Direction of rotation: The opposite direction when facing C and A
- Efficiency: Size 1 $\eta = 0,90 - 0,92$
Size 2 $\eta = 0,90 - 0,93$
Size 4 $\eta = 0,92 - 0,94$
- Life time: 20000 h
- Permissible gearbox temperature at housing: -10 °C to $+90\text{ °C}$
- Lubrication: Oil lubrication
- Mounting position: Any, please specify when ordering
- Surface protection: Primer coat RAL 9005 black
- Protection rating: IP 54



MKS			1															
			without offset												with offset			
Ratio	i		6	7,5	9,6	12	14,4	16,8	19,2	21,6	24	26,4	28,8	33,6	38,4	43,2	48	
Max. acceleration torque (max. 1000 cycles per hour)	T_{2bzul}	Nm	120	120	130	130	130	120	120	120	130	130	130	130	120	120	120	120
Nominal torque on output shaft (at n_{1Nzul})	T_{2Nzul}	Nm	100	100	110	110	110	100	100	100	110	110	110	110	100	100	100	100
Emergency stop torque (permissible 1000 times during gearbox life time)	$T_{2Notzul}$	Nm	250	250	275	275	275	250	250	250	275	275	275	275	250	250	250	250
Permissible average input speed (with T_{2Nzul} and 20 °C ambient temperature)	n_{1mzul}	min ⁻¹	3000												3000			
Max. input speed	$n_{1maxzul}$	min ⁻¹	5000												5000			
Max. backlash*	j	arcmin	≤ 4															
Torsional rigidity [▲]	C	Nm/arcmin	on request															
Max. radial load** (with reference to shaft centre on output shaft)	F_{2rzul}	N	4800															
Max. axial load*** (with reference to shaft centre on output shaft)	F_{2azul}	N	2400															
Weight	m	kg	approx. 9															
Running noise (with $n_1 = 3000\text{ min}^{-1}$ without load)	L_{PA}	dB(A)	approx. 75 / distance of 1 m															
Inertia (with reference to input)	$\varnothing d\ 9$	J_1	kgcm ²	1,16	1,19	1,20	0,94	0,79	0,82	0,81	0,74	0,78	0,75	0,75	0,71	0,71	0,70	0,69
	$\varnothing d\ 11$	J_1	kgcm ²	1,21	1,25	1,26	1,00	0,84	0,87	0,91	0,80	0,84	0,82	0,80	0,77	0,76	0,76	0,75
	$\varnothing d\ 14$	J_1	kgcm ²	1,34	1,38	1,39	1,12	0,96	0,99	1,03	0,93	0,96	0,94	0,94	0,90	0,89	0,89	0,87
	$\varnothing d\ 19$	J_1	kgcm ²	1,70	1,74	1,75	1,49	1,31	1,36	1,49	1,33	1,40	1,39	1,36	1,27	1,26	1,24	1,24

[▲]with reference to output

* measured with 2 % nominal torque on output shaft

**charge centre of output shaft at output speed 250 min⁻¹. Please contact us for combined load applications

*** please consult the manufacturer for details of version with shrink disc

perm. torques at $n_1 = 1500\text{ min}^{-1}$



MKS 1 - MKS 4

TECHNICAL DATA

The following technical specifications in the table are intended only for rough preselection

MKS			2															
			without offset												with offset			
Ratio	i		6	7,5	9,6	12	14,4	16,8	19,2	21,6	24	26,4	28,8	33,6	38,4	43,2	48	
Max. acceleration torque (max. 1000 cycles per hour)	T_{2bzul}	Nm	200	210	240	240	240	230	220	220	200	200	200	200	200	180	180	
Nominal torque on output shaft (at n_{1Nzul})	T_{2Nzul}	Nm	160	170	200	200	200	190	180	180	160	160	150	150	150	150	150	
Emergency stop torque (permissible 1000 times during gearbox life time)	$T_{2Notzul}$	Nm	400	425	500	500	500	475	450	450	400	400	375	375	375	375	375	
Permissible average input speed (with T_{2Nzul} and 20 °C ambient temperature)	n_{1mzul}	min ⁻¹	3000												3000			
Max. input speed	$n_{1maxzul}$	min ⁻¹	5000												5000			
Max. backlash*	j	arcmin	≤ 4															
Torsional rigidity [▲]	C	Nm/arcmin	on request															
Max. radial load** (with reference to shaft centre on output shaft)	F_{2rzul}	N	6500															
Max. axial load*** (with reference to shaft centre on output shaft)	F_{2azul}	N	3250															
Weight	m	kg	approx. 13,5															
Running noise (with $n_1 = 3000$ min ⁻¹ without load)	L_{PA}	dB(A)	approx. 75 / distance of 1 m															
Inertia (with reference to input)	Ø d 9	J_1	kgcm ²	2,09	1,57	1,71	1,01	1,15	1,00	0,91	0,88	0,85	0,84	0,76	0,75	0,74	0,73	0,71
	Ø d 11	J_1	kgcm ²	2,15	1,63	1,77	1,07	1,21	1,06	0,97	0,94	0,91	0,90	0,88	0,81	0,80	0,79	0,77
	Ø d 14	J_1	kgcm ²	2,27	1,76	1,90	1,19	1,34	1,19	1,09	1,06	1,03	1,03	1,00	0,93	0,92	0,92	0,89
	Ø d 19	J_1	kgcm ²	2,64	2,12	2,26	1,55	1,70	1,55	1,63	1,43	1,40	1,40	1,37	1,30	1,29	1,28	1,26

MKS			4															
			without offset												with offset			
Ratio	i		6	7,5	9,6	12	14,4	16,8	19,2	21,6	24	26,4	28,8	33,6	38,4	43,2	48	
Max. acceleration torque (max. 1000 cycles per hour)	T_{2bzul}	Nm	420	420	460	450	450	450	450	440	440	450	450	450	440	440	440	
Nominal torque on output shaft (at n_{1Nzul})	T_{2Nzul}	Nm	360	360	400	400	400	400	400	380	380	400	400	400	400	400	400	
Emergency stop torque (permissible 1000 times during gearbox life time)	$T_{2Notzul}$	Nm	900	900	1000	1000	1000	1000	1000	950	950	1000	1000	1000	1000	1000	1000	
Permissible average input speed (with T_{2Nzul} and 20 °C ambient temperature)	n_{1mzul}	min ⁻¹	3000												3000			
Max. input speed	$n_{1maxzul}$	min ⁻¹	5000												5000			
Max. backlash*	j	arcmin	≤ 4															
Torsional rigidity [▲]	C	Nm/arcmin	on request															
Max. radial load** (with reference to shaft centre on output shaft)	F_{2rzul}	N	10000															
Max. axial load*** (with reference to shaft centre on output shaft)	F_{2azul}	N	5000															
Weight	m	kg	approx. 23,5															
Running noise (with $n_1 = 3000$ min ⁻¹ without load)	L_{PA}	dB(A)	approx. 75 / distance of 1 m															
Inertia (with reference to input)	Ø d 9	J_1	kgcm ²	7,62	8,10	6,48	5,30	4,62	3,98	3,75	3,22	3,33	3,00	3,02	2,79	2,68	2,60	2,57
	Ø d 11	J_1	kgcm ²	7,65	8,20	6,51	5,37	4,69	4,05	3,81	3,28	3,39	3,06	3,09	2,86	2,74	2,54	2,53
	Ø d 14	J_1	kgcm ²	7,80	8,32	6,66	5,49	4,81	4,17	3,94	3,40	3,52	3,19	3,21	2,98	2,87	2,79	2,76
	Ø d 19	J_1	kgcm ²	8,28	8,69	7,15	5,85	5,17	4,54	4,30	3,77	3,88	3,55	3,58	3,35	3,23	3,16	3,12
	Ø d 24	J_1	kgcm ²	9,37	9,64	8,20	6,91	6,23	5,59	5,36	4,82	4,76	4,61	4,63	4,40	4,35	4,21	4,17
	Ø d 28	J_1	kgcm ²	11,60	11,84	10,47	9,10	8,42	7,79	7,55	7,02	7,13	6,80	6,83	6,60	6,48	6,41	6,37
	Ø d 32	J_1	kgcm ²	12,21	12,43	11,00	9,75	8,96	8,24	7,96	7,63	7,64	7,40	7,38	7,18	6,99	6,95	6,88

[▲]with reference to output

* measured with 2 % nominal torque on output shaft

**charge centre of output shaft at output speed 250 min⁻¹. Please contact us for combined load applications

*** please consult the manufacturer for details of version with shrink disc

perm. torques at $n_1 = 1500$ min⁻¹

MKS 1 - MKS 4

DIMENSIONS

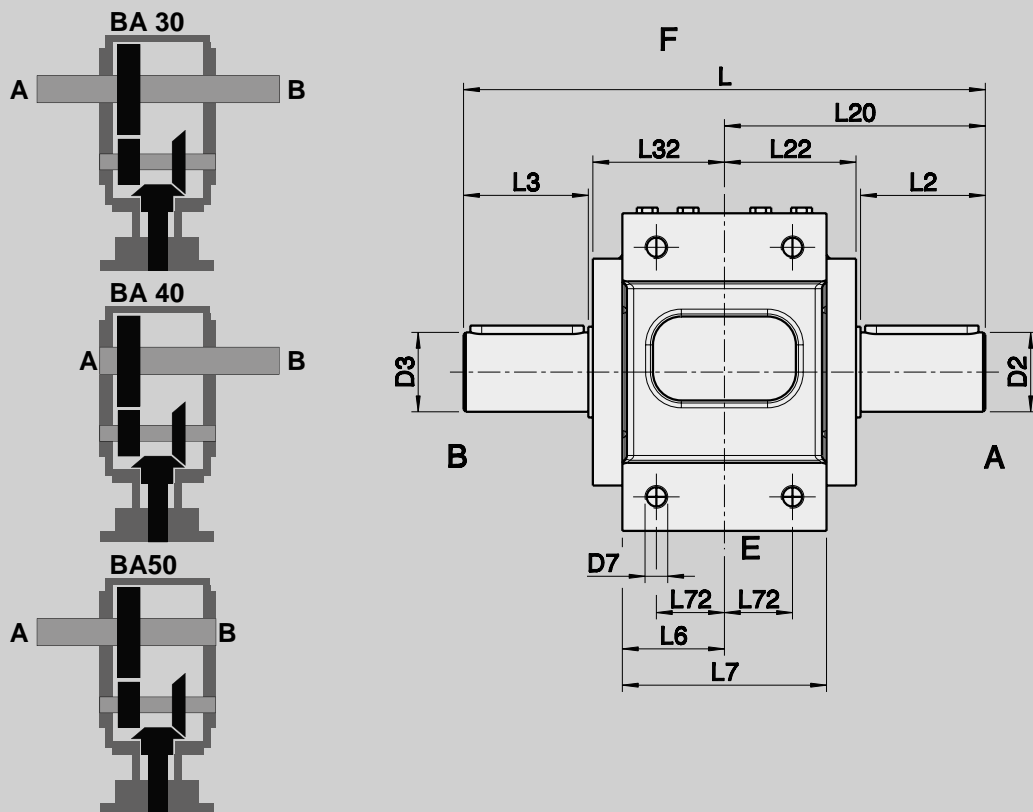

d	x	l1	Size	D2	D3	D7	D14	D16	Key D2/D3 according to DIN 6885/1	L	L2	L3	L4	L5	L6	L7
G7				j6	j6		f7									
9	x	20	1	30	30	M8	88	72	8x7x40	200	47	47	58	55	37,5	75
11	x	23														
14	x	35														
19	x	40	2	35	35	M10	100	75	10x8x50	230	55	55	70	70	45	90
9	x	20														
11	x	23														
14	x	35	4	45	45	M12	127	90	14x9x60	280	70	70	85	85	55	110
19	x	40														
11	x	23														
14	x	30														
19	x	40														
24	x	50														
28	x	60														
32	x	60														

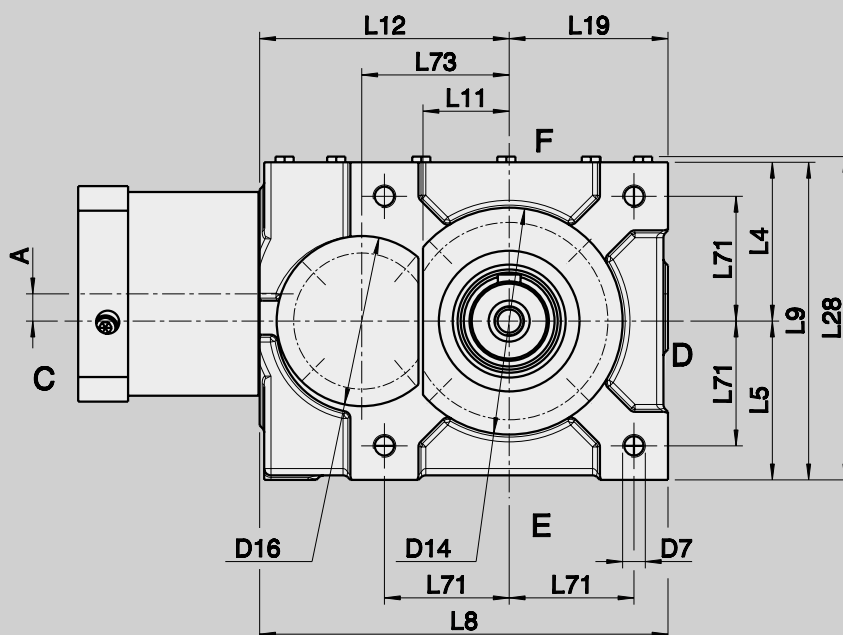

d	x	l1	Size	L8	L9	L11	L12	L19	L20	L22	L28	L32	L71	L72	L73	A*
G7																
9	x	20	1	155	113	33	110	55	100	51	116,5	51	44	28	55	12 / 0
11	x	23														
14	x	35														
19	x	40														
9	x	20	2	180	140	39	120	70	115	58	145	58	55	30	65	12 / 0
11	x	23														
14	x	35														
19	x	40														
11	x	23	4	227	170	50	157	85	140	68	175	68	67	37	82	18 / 0
14	x	30														
19	x	40														
24	x	50														
28	x	60														
32	x	60														

* from ratio 33,6 otherwise 0

MKS 1 - MKS 4

DIMENSIONS MOTOR MOUNTING

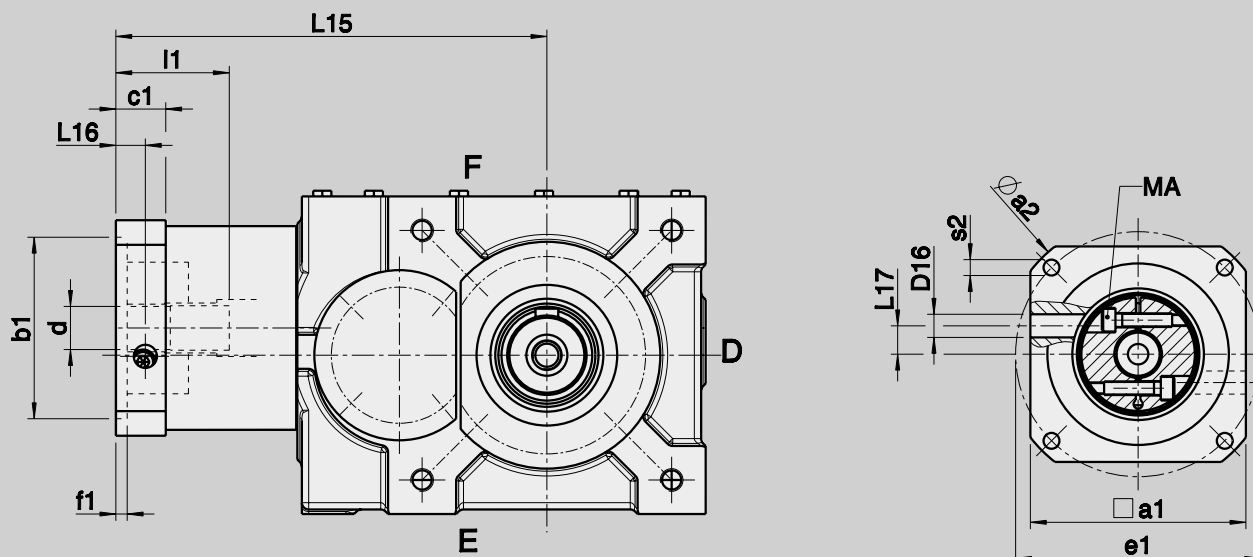

Gearbox dimensions

d	x	l1	Size	L15	L16	L17	c1	f1	D16	Screw type	MA
											[Nm]
9	x	20	1	180	13	12,5	22	5	10	M6 / 12.9	18
11	x	23		180	13	12,5	22	5	10	M6 / 12.9	18
14	x	30		180	13	12,5	22	5	10	M6 / 12.9	18
19	x	40		180	13	12,5	22	5	10	M6 / 12.9	18
9	x	20	2	190	13	12,5	22	5	10	M6 / 12.9	18
11	x	23		190	13	12,5	22	5	10	M6 / 12.9	18
14	x	30		190	13	12,5	22	5	10	M6 / 12.9	18
19	x	40		190	13	12,5	22	5	10	M6 / 12.9	18
11	x	23	4	227	15	16,5	25	5	14	M6 / 12.9	18
14	x	30		227	15	16,5	25	5	14	M6 / 12.9	18
19	x	40		227	15	16,5	25	5	14	M8 / 12.9	39
24	x	50		227	15	16,5	25	5	14	M8 / 12.9	43
28	x	60		227	15	16,5	25	5	14	M8 / 12.9	43
32	x	60		227	15	16,5	25	5	14	M8 / 12.9	43



Motor dimensions

a1		95	95	115	125	125	130	140
a2		105	120	140	140	140	160	190
b1	G8	70	80	95	80	95	110	130
e1		85	100	115	100	115	130	165
s2		M6	M6	M8	M6	M8	M8	M10
		x12	x12	x16	x12	x16	x16	x20
		∅ 7,0	∅ 7,0	∅ 9,0	∅ 7,0	∅ 9,0	∅ 9,0	∅ 11,0

	x	x	x			x	
	x	x	x			x	
	x	x	x			x	
	x	x	x			x	
	x	x	x			x	
				x	x	x	x
				x	x	x	x
				x	x	x	x
				x	x	x	x
				x	x	x	x

M K S H

TECHNICAL DATA

Technical specifications on this page and in the tables on the following two pages are intended only for rough preselection.

- Gear teeth: MKSH 1 – MKSH 4
Klingelnberg spiral bevel toothing ground
- Direction of rotation: The opposite direction when facing C and A
- Efficiency: Size 1 $\eta = 0,90 - 0,92$
Size 2 $\eta = 0,90 - 0,93$
Size 4 $\eta = 0,92 - 0,94$
- Life time: 20000 h
- Permissible gearbox temperature at housing: -10 °C to $+90\text{ °C}$
- Lubrication: Oil lubrication
- Mounting position: Any, please specify when ordering
- Surface protection: Primer coat RAL 9005 black
- Protection rating: IP 54



MKSH			1															
			without offset												with offset			
Ratio	i		6	7,5	9,6	12	14,4	16,8	19,2	21,6	24	26,4	28,8	33,6	38,4	43,2	48	
Max. acceleration torque (max. 1000 cycles per hour)	T_{2bzul}	Nm	120	120	130	130	130	120	120	120	130	130	130	130	120	120	120	120
Nominal torque on output shaft (at n_{1Nzul})	T_{2Nzul}	Nm	100	100	110	110	110	100	100	100	110	110	110	110	100	100	100	100
Emergency stop torque (permissible 1000 times during gearbox life time)	$T_{2Notzul}$	Nm	250	250	275	275	275	250	250	250	275	275	275	275	250	250	250	250
Permissible average input speed (with T_{2Nzul} and 20 °C ambient temperature)	n_{1mzul}	min^{-1}	3000												3000			
Max. input speed	$n_{1maxzul}$	min^{-1}	5000												5000			
Max. backlash*	j	arcmin	≤ 4															
Torsional rigidity [▲]	C	Nm/arcmin	on request															
Max. radial load** (with reference to shaft centre on output shaft)	F_{2rzul}	N	4800															
Max. axial load*** (with reference to shaft centre on output shaft)	F_{2azul}	N	2400															
Weight	m	kg	approx. 9															
Running noise (with $n_1 = 3000\text{ min}^{-1}$ without load)	L_{PA}	dB(A)	approx. 75 / distance of 1 m															
Inertia (with reference to input)	$\varnothing d\ 9$	J_1	kgcm ²	1,16	1,19	1,20	0,94	0,79	0,82	0,81	0,74	0,78	0,75	0,75	0,71	0,71	0,70	0,69
	$\varnothing d\ 11$	J_1	kgcm ²	1,21	1,25	1,26	1,00	0,84	0,87	0,91	0,80	0,84	0,82	0,80	0,77	0,76	0,76	0,75
	$\varnothing d\ 14$	J_1	kgcm ²	1,34	1,38	1,39	1,12	0,96	0,99	1,03	0,93	0,96	0,94	0,94	0,90	0,89	0,89	0,87
	$\varnothing d\ 19$	J_1	kgcm ²	1,70	1,74	1,75	1,49	1,31	1,36	1,49	1,33	1,40	1,39	1,36	1,27	1,26	1,24	1,24

[▲]with reference to output

* measured with 2 % nominal torque on output shaft

**charge centre of output shaft at output speed 250 min^{-1} . Please contact us for combined load applications

*** please consult the manufacturer for details of version with shrink disc

perm. torques at $n_1 = 1500\text{ min}^{-1}$



MKSH 1 - MKSH 4

TECHNICAL DATA

The following technical specifications in the table are intended only for rough preselection

MKSH			2															
			without offset												with offset			
Ratio	i		6	7,5	9,6	12	14,4	16,8	19,2	21,6	24	26,4	28,8	33,6	38,4	43,2	48	
Max. acceleration torque (max. 1000 cycles per hour)	T _{2bzul}	Nm	200	210	240	240	240	230	220	220	200	200	200	200	200	180	180	
Nominal torque on output shaft (at n _{1Nzul})	T _{2Nzul}	Nm	160	170	200	200	200	190	180	180	160	160	150	150	150	150	150	
Emergency stop torque (permissible 1000 times during gearbox life time)	T _{2Notzul}	Nm	400	425	500	500	500	475	450	450	400	400	375	375	375	375	375	
Permissible average input speed (with T _{2Nzul} and 20 °C ambient temperature)	n _{1mzul}	min ⁻¹	3000												3000			
Max. input speed	n _{1maxzul}	min ⁻¹	5000												5000			
Max. backlash*	j	arcmin	≤ 4															
Torsional rigidity [▲]	C	Nm/arcmin	on request															
Max. radial load** (with reference to shaft centre on output shaft)	F _{2rzul}	N	6500															
Max. axial load*** (with reference to shaft centre on output shaft)	F _{2azul}	N	3250															
Weight	m	kg	approx. 13,5															
Running noise (with n ₁ = 3000 min ⁻¹ without load)	L _{PA}	dB(A)	approx. 75 / distance of 1 m															
Inertia (with reference to input)	∅ d 9	J ₁	kgcm ²	2,09	1,57	1,71	1,01	1,15	1,00	0,91	0,88	0,85	0,84	0,76	0,75	0,74	0,73	0,71
	∅ d 11	J ₁	kgcm ²	2,15	1,63	1,77	1,07	1,21	1,06	0,97	0,94	0,91	0,90	0,88	0,81	0,80	0,79	0,77
	∅ d 14	J ₁	kgcm ²	2,27	1,76	1,90	1,19	1,34	1,19	1,09	1,06	1,03	1,03	1,00	0,93	0,92	0,92	0,89
	∅ d 19	J ₁	kgcm ²	2,64	2,12	2,26	1,55	1,70	1,55	1,63	1,43	1,40	1,40	1,37	1,30	1,29	1,28	1,26

MKSH			4															
			without offset												with offset			
Ratio	i		6	7,5	9,6	12	14,4	16,8	19,2	21,6	24	26,4	28,8	33,6	38,4	43,2	48	
Max. acceleration torque (max. 1000 cycles per hour)	T _{2bzul}	Nm	420	420	460	450	450	450	450	440	440	450	450	450	440	440	440	
Nominal torque on output shaft (at n _{1Nzul})	T _{2Nzul}	Nm	360	360	400	400	400	400	400	380	380	400	400	400	400	400	400	
Emergency stop torque (permissible 1000 times during gearbox life time)	T _{2Notzul}	Nm	900	900	1000	1000	1000	1000	1000	950	950	1000	1000	1000	1000	1000	1000	
Permissible average input speed (with T _{2Nzul} and 20 °C ambient temperature)	n _{1mzul}	min ⁻¹	3000												3000			
Max. input speed	n _{1maxzul}	min ⁻¹	5000												5000			
Max. backlash*	j	arcmin	≤ 4															
Torsional rigidity [▲]	C	Nm/arcmin	on request															
Max. radial load** (with reference to shaft centre on output shaft)	F _{2rzul}	N	10000															
Max. axial load*** (with reference to shaft centre on output shaft)	F _{2azul}	N	5000															
Weight	m	kg	approx. 23,5															
Running noise (with n ₁ = 3000 min ⁻¹ without load)	L _{PA}	dB(A)	approx. 75 / distance of 1 m															
Inertia (with reference to input)	∅ d 9	J ₁	kgcm ²	7,62	8,10	6,48	5,30	4,62	3,98	3,75	3,22	3,33	3,00	3,02	2,79	2,68	2,60	2,57
	∅ d 11	J ₁	kgcm ²	7,65	8,20	6,51	5,37	4,69	4,05	3,81	3,28	3,39	3,06	3,09	2,86	2,74	2,54	2,53
	∅ d 14	J ₁	kgcm ²	7,80	8,32	6,66	5,49	4,81	4,17	3,94	3,40	3,52	3,19	3,21	2,98	2,87	2,79	2,76
	∅ d 19	J ₁	kgcm ²	8,28	8,69	7,15	5,85	5,17	4,54	4,30	3,77	3,88	3,55	3,58	3,35	3,23	3,16	3,12
	∅ d 24	J ₁	kgcm ²	9,37	9,64	8,20	6,91	6,23	5,59	5,36	4,82	4,76	4,61	4,63	4,40	4,35	4,21	4,17
	∅ d 28	J ₁	kgcm ²	11,60	11,84	10,47	9,10	8,42	7,79	7,55	7,02	7,13	6,80	6,83	6,60	6,48	6,41	6,37
	∅ d 32	J ₁	kgcm ²	12,21	12,43	11,00	9,75	8,96	8,24	7,96	7,63	7,64	7,40	7,38	7,18	6,99	6,95	6,88

perm. torques at n₁ = 1500 min⁻¹

▲with reference to output
* measured with 2 % nominal torque on output shaft
**charge centre of output shaft at output speed 250 min⁻¹. Please contact us for combined load applications
*** please consult the manufacturer for details of version with shrink disc

MKSH 1 - MKSH 4

DIMENSIONS

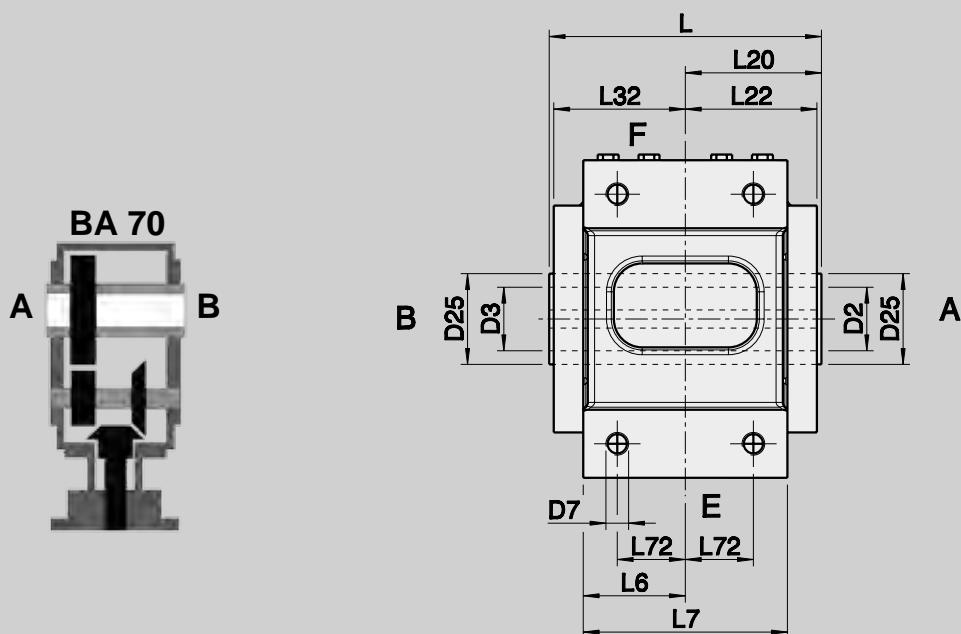

d	x	l1	Size	D2	D3	D7	D14	D16	D25	Keyway according to DIN 6885/1	L	L4	L5	L6	L7
G7				H7	H7		f7			JS9					
9	x	20	1	22	22	M8	88	72	35	6	106	58	55	37,5	75
11	x	23													
14	x	35													
19	x	40													
9	x	20	2	28	28	M10	100	75	40	8	120	70	70	45	90
11	x	23													
14	x	35													
19	x	40													
11	x	23	4	38	38	M12	127	90	55	10	140	85	85	55	110
14	x	30													
19	x	40													
24	x	50													
28	x	60													
32	x	60													

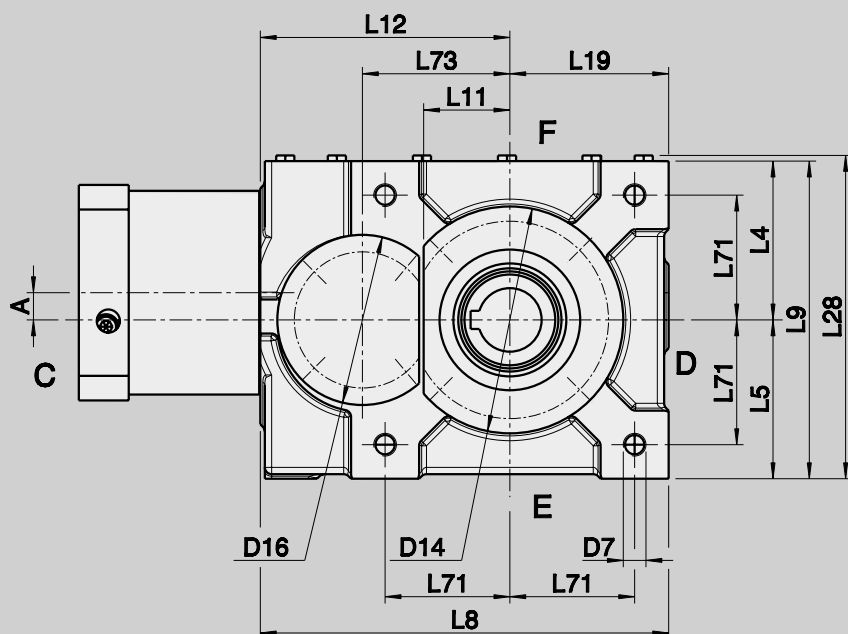

d	x	l1	Size	L8	L9	L11	L12	L19	L20	L22	L28	L32	L71	L72	L73	A*
G7																
9	x	20	1	155	113	33	110	55	53	51	116,5	51	44	28	55	12 / 0
11	x	23														
14	x	35														
19	x	40														
9	x	20	2	180	140	39	120	70	60	58	145	58	55	30	65	12 / 0
11	x	23														
14	x	35														
19	x	40	4	227	170	50	157	85	70	68	175	68	67	37	82	18 / 0
11	x	23														
14	x	30														
19	x	40														
24	x	50														
28	x	60														
32	x	60														

* from ratio 33,6 otherwise 0

MKSH 1 - MKSH 4

DIMENSIONS MOTOR MOUNTING

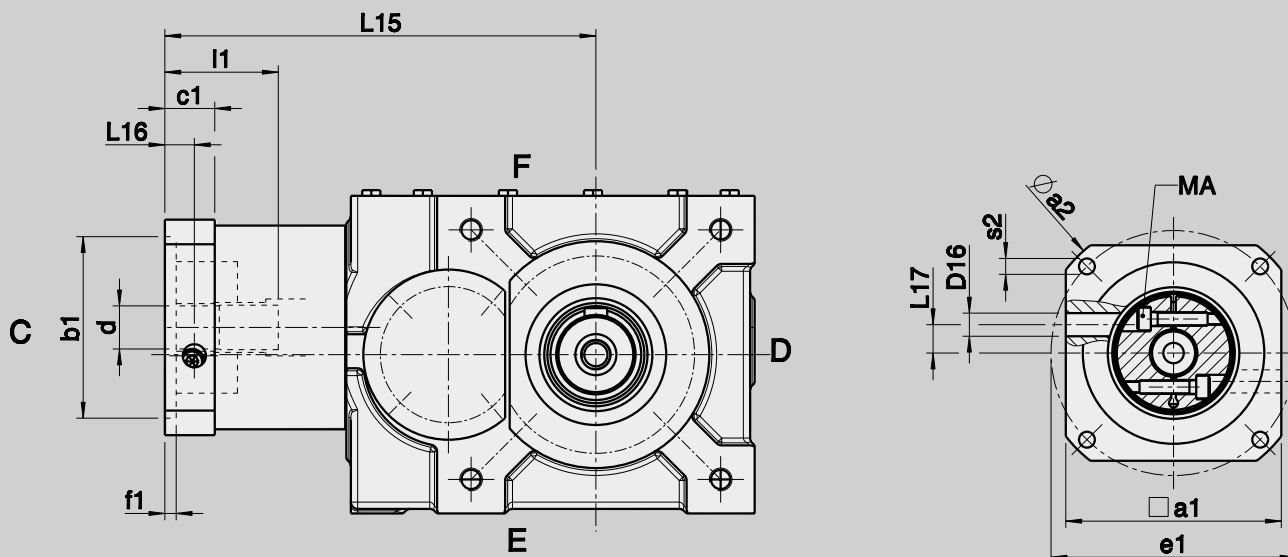

Gearbox dimensions

d	x	l1	Size	L15	L16	L17	c1	f1	D16	Screw type	MA
G7											[Nm]
9	x	20	1	180	13	12,5	22	5	10	M6 / 12.9	18
11	x	23		180	13	12,5	22	5	10	M6 / 12.9	18
14	x	30		180	13	12,5	22	5	10	M6 / 12.9	18
19	x	40		180	13	12,5	22	5	10	M6 / 12.9	18
9	x	20	2	190	13	12,5	22	5	10	M6 / 12.9	18
11	x	23		190	13	12,5	22	5	10	M6 / 12.9	18
14	x	30		190	13	12,5	22	5	10	M6 / 12.9	18
19	x	40		190	13	12,5	22	5	10	M6 / 12.9	18
11	x	23	4	227	15	16,5	25	5	14	M6 / 12.9	18
14	x	30		227	15	16,5	25	5	14	M6 / 12.9	18
19	x	40		227	15	16,5	25	5	14	M8 / 12.9	39
24	x	50		227	15	16,5	25	5	14	M8 / 12.9	43
28	x	60		227	15	16,5	25	5	14	M8 / 12.9	43
32	x	60		227	15	16,5	25	5	14	M8 / 12.9	43



Motor dimensions

a1		95	95	115	125	125	130	140
a2		105	120	140	140	140	160	190
b1	G8	70	80	95	80	95	110	130
e1		85	100	115	100	115	130	165
s2		M6	M6	M8	M6	M8	M8	M10
		x12	x12	x16	x12	x16	x16	x20
		∅ 7,0	∅ 7,0	∅ 9,0	∅ 7,0	∅ 9,0	∅ 9,0	∅ 11,0

	x	x	x			x	
	x	x	x			x	
	x	x	x			x	
	x	x	x			x	
	x	x	x			x	
				x	x	x	x
				x	x	x	x
				x	x	x	x
				x	x	x	x
				x	x	x	x

ADDITIONAL OPTIONS
MKSHF 1 - MKSHF 4 OUTPUT FLANGE
DIMENSIONS

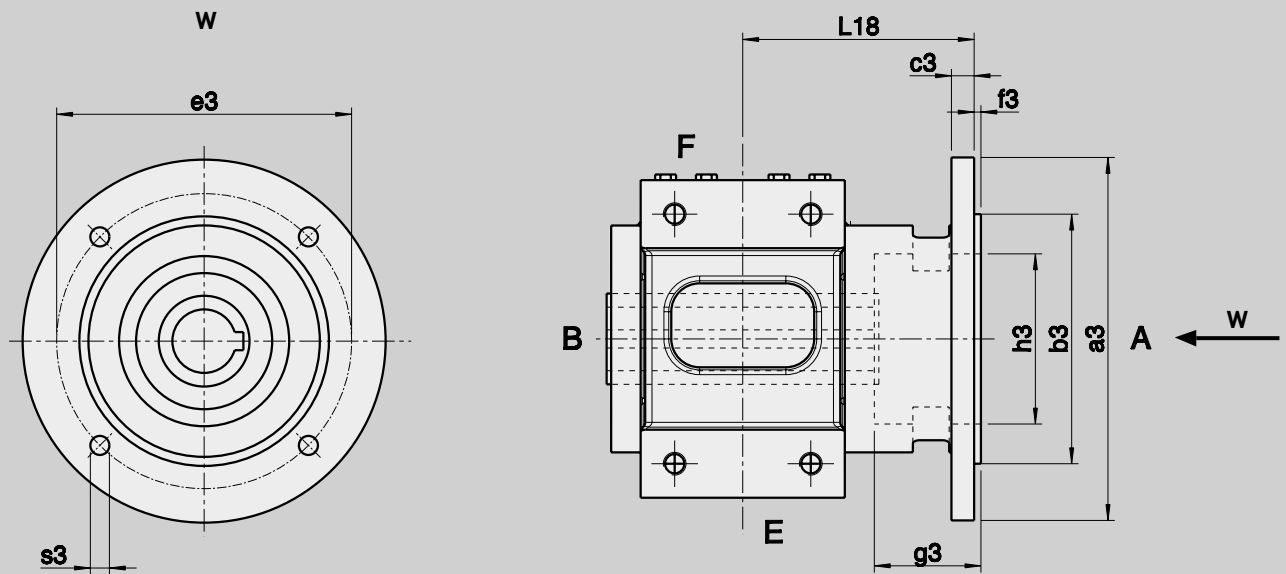

Order option: Flange and shrink disc available on either side A or B.

Size	a3	b3	c3	e3	f3	g3	h3	s3	L18
		f7							
1	140	95	10	115	3	35	63	Ø9	83
2	160	110	10	130	3	47	75	Ø9	102
4	200	130	10	165	3	52	96	Ø11	120

ADDITIONAL OPTIONS
MKSH 1 - MKSH 4
DIMENSIONS

SHRINK DISC



Attached on side B

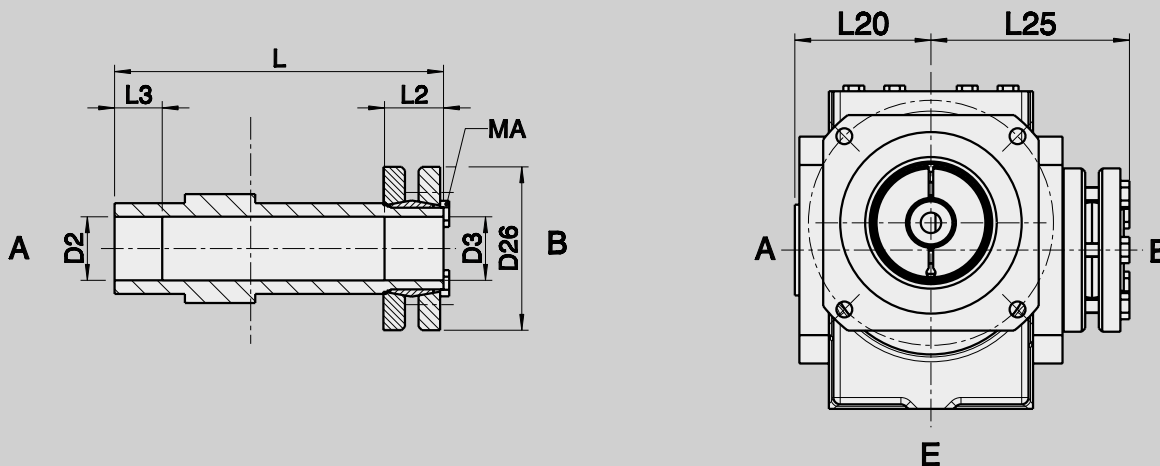

Order option: Flange and shrink disc available on either side A or B.
 MKSH BA70 hollow shaft with shrink disc available either side A or B. MKSHF flange and shrink disc available either side A or B.

Size	D2/D3	D26	L	L20	L25	L2/L3	MA
	H7						
1	25	60	133	53	86	20	The required clamping torques MA can be found on the shrink disc.
2	28	72	145	60	88	26	
4	38	90	170	70	102	30	

MOTOR MOUNTING FOR ALL TYPES

The connection between motor and gearbox is made using a shrink disc bush without a keyway. For maximum performance we recommend the use of motors with reduced shaft tolerance and concentricity according to DIN 42955 R standards.

When fitting the motor, position the gearbox vertically with the motor flange upwards. Before assembly, degrease the motor shaft and the blind hole in the gearbox. Remove the lock screw or two plastic plugs from the motor flange of the gearbox, and insert a long Allen key to reach the tangential clamping screw in the coupling. The coupling must first be turned to the correct position for the screw to be accessible. Lower the motor vertically with the motor shaft in the blind hole. Ensure that the motor shaft has completely entered the bore, and that the flanges of motor and gearbox are in contact with each other over their full surface. The motor flange screws can now be inserted (do not tighten them completely). Then tighten the screws of the coupling with the required tightening torque. Do this in 3 steps alternately with 20 %, 50 % and then 100 %.

The torque values for motor mounting can be found in our motor mounting manual, which is offered separately. Finish tightening the motor flange screws. After assembly, it is important to reinsert the lock screw or plastic plugs into their holes.

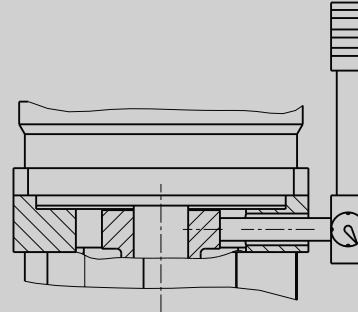

NOTES

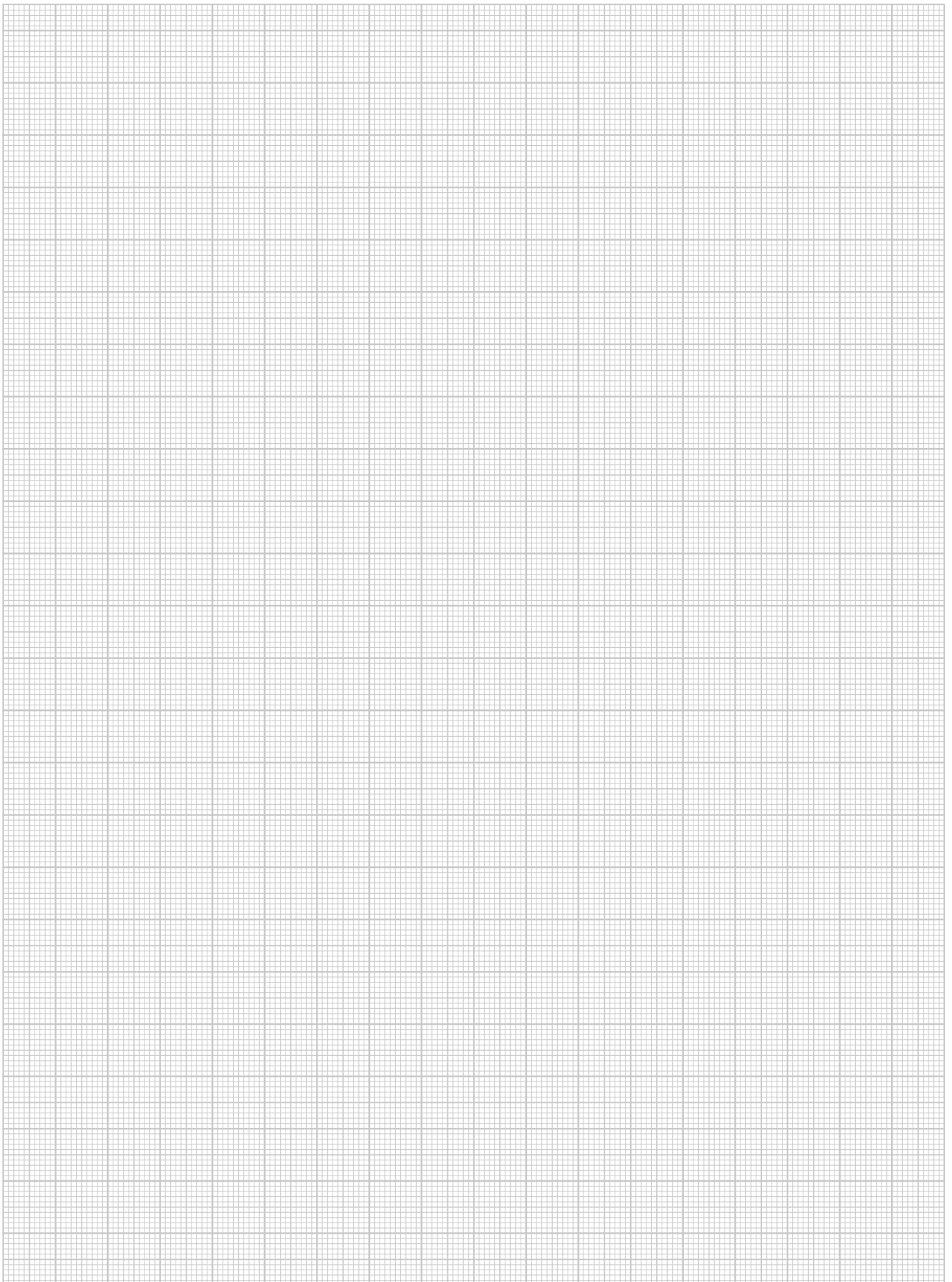

ENQUIRY AND ORDER FORM

Gearbox data

Symbol

Unit

Quantity

Gearbox type

Gearbox size

Ratio

i

Construction type

Backlash

j

arcmin

Standard

Reduced

Value

Operating hours/year:

Operating hours/day:

Duty:

%

ED

Lubrication

Synthetic

Oil

For use in the food industry

Mineral

Grease

Side under:

Breather side:

Oil sight glass side:

Drainage side:

Gearbox performance data

Symbol

Unit

Nominal input speed

n_{1N}

min^{-1}

Max. input speed

$n_{1\text{maxzul}}$

min^{-1}

Nominal output torque

$T_{2N\text{zul}}$

Nm

Max. output torque

$T_{2\text{max}}$

Nm

Nominal power input

P_{1N}

kW

Max. power input

$P_{1\text{max}}$

kW

Gearbox shaft loads output

Symbol

Unit

Radial load output

F_{2r}

N

Distance radial

y₂

mm

Distance axial

x₂

mm

Axial load output

F_{2a}

N

Distance radial

y₂

mm

Distance axial

x₂

mm

According to drawing

ENQUIRY AND ORDER FORM

Application

Duty type

No. of cycles

Z 1/h

Ambient temperature

°C

Ambient air

Free of particles Dust
 Fibres Gas

Other:

Customer drawing - Application - Number

Motor data

Symbol

Unit

Motor type

Capacity

kW

Speed

min⁻¹

Outer dim. flange

mm

Centring-Ø (b1)

mm

Pitch circle-Ø (e1)

mm

Motor mounting (s2)

Motor shaft (Ø d x l1)

mm

Direct connection

Yes No

Connection through coupling:

Additional data for ATEX versions

Symbol

Unit

Category:

Zone:

Explosion group:

Temperature class:

Max. surface temperature:

°C

Note!

Missing data will be clarified individually. Further information following design.

Further information/requirements:

Blank lines for further information/requirements.